

# Oil / Air Cooler Series BLK

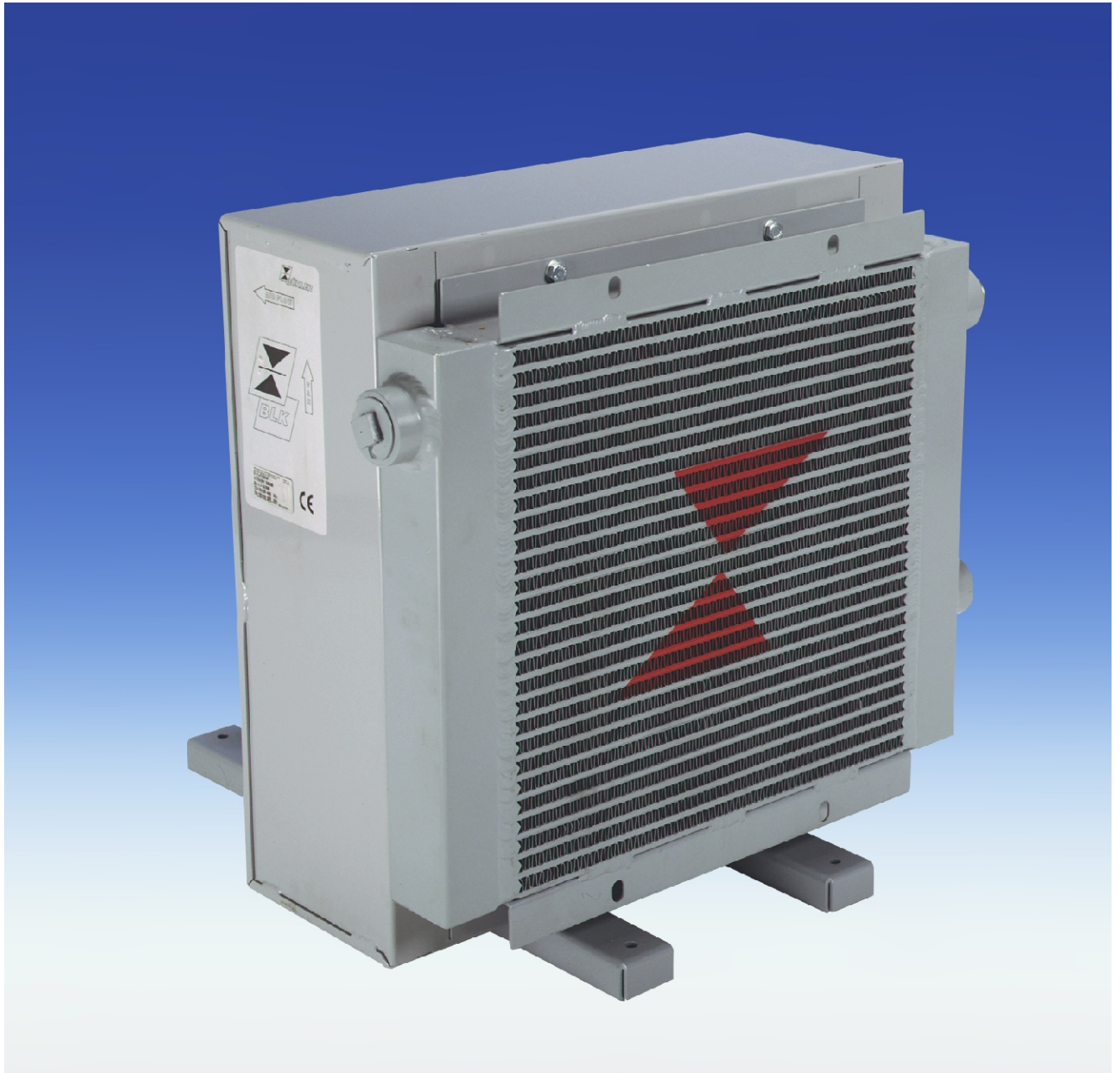

- Maintenance friendly design
- Compact dimensions
- Low noise emissions
- Broad performance range
- Rugged cooling matrix
- Comprehensive accessories

## Why coolers?

There are basically two main concepts in the development of fluid power systems. One is to design systems without using a cooler, and if operational conditions show that the system needs a cooler, install it later at additional costs.

The other concept recognises that a system originally designed with an integrated cooler is more compact, needs less installation space and is more reliable due to the stabilized temperature of the fluid.

## Why Bühler?

Today's requirements for an oil/air cooler demand for an effective and compact design with low noise emission and very easy maintenance.

The development of the new BLK series is based on over 30 years of experience in design and sales of air/oil-coolers. In particular the fatigue life of the cooling matrix was highlighted in the development as the matrix has to withstand pressure peaks in the return line.

Due to the exposure to the various ambient conditions air/oil cooler matrixes inevitably require some maintenance. Therefore the cooling matrix can be easily separated from the fan case without the need to dismantle the ventilator, the motor or any other parts.

If our comprehensive standard range of products does not have the solution for your application we will be pleased to find special solutions for your application.

The data contained in this leaflet should be sufficient to determine the right cooler for your application. However, we can offer you a computer program which makes this sizing easier for you.



BNK



BNF, BKF

## Description

The BLK series consist of the following components:

- cooler matrix
- fan case with mounting feet
- fan motor assembly consisting of AC motor, fan and finger guard

The cooling matrix and fan can be separated from the fan case individually without the need to dismantle other components.

The cooling matrix of the BLK series is made from aluminium. The matrix is suitable for use with hydraulic fluids but is not suitable for water or water based fluids.

The cooling matrix can be equipped with by-pass valves of different configurations (see type code).

Please note the installation chapter.

Depending on the application or system requirements, off line filtration is often the appropriate solution. We recommend in these cases that you combine this off line circuit with an off line cooler. Suitable units can be found in our BNK series. These units are also suitable for upgrading existing systems.

## Sizing the right Cooler

The determination of a cooler follows two steps:

- determination of cooler size
- determination of expected pressure loss

### Definitions

$t_{OE}$ [°C]	inlet oil temperature
$t_{LE}$ [°C]	inlet air temperature
<b>ETD</b> [K]	temperature differential: <b>ETD = <math>t_{OE} - t_{LE}</math></b>
$P_{spez}$ [kW / K]	specific cooling performance (see performance curves) <b><math>P_{spez} = P / ETD</math></b>
<b>P</b> [kW]	cooling performance in kW
<b>Q</b> [l/min]	oil flow rate
$C_{oi}$ [kJ/kgK]	specific heat capacity of oil (approx. 2.0 kJ / kgK)
[kg/dm <sup>3</sup> ]	specific gravity of oil $\approx 0.9$ kg/dm <sup>3</sup>

### Calculation Example:

#### Assumptions:

Tank capacity	(V)	ca. 200 l
Start up temperature of oil	( $T_1$ )	15 °C
The oil is heated up approx.		
25 minutes to	( $T_2$ )	45 °C
Required oil temperature	( $t_{OE}$ )	60 °C
Inlet air temperature	( $t_{LE}$ )	30 °C
Oil flow rate	(Q)	80 l/min

### Pressure loss curves determined with an average viscosity of 30 cSt

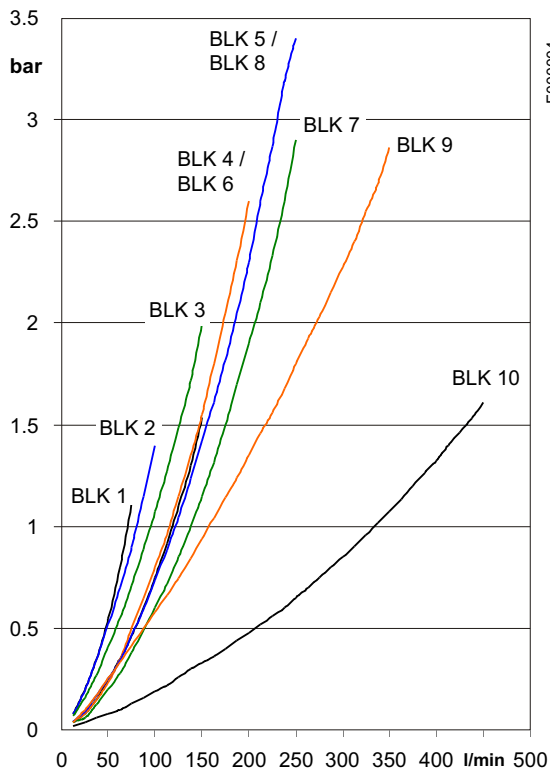

**Attention:** If the coolers are used in open air or the oil has even higher viscosity the installation of by-pass valves may be necessary. Please check the section "functions schemes".

### Calculation

1. Calculation of P

$$P = \frac{200 \times 0.9 \times 2.0 \times (45-15)}{25 \times 60} = 7.2 \text{ kW}$$

2. ETD =  $t_{OE} - t_{LE} = 60^\circ\text{C} - 30^\circ\text{C} = 30 \text{ K}$

3. Required specific performance:

$$P_{spez} = P / ETD = 7.2 \text{ kW} / 30 \text{ K} = 0.24 \text{ kW/K}$$

4. Using the graph, select a cooler at 80 l/min with:

$$P_{spez} 0.24 \text{ kW/K:}$$

There are two possibilities:

BLK 2.2, or alternatively BLK 3.4, this cooler is larger but has the lower noise emission

### Temperature/viscosity table

Type of oil	at 50°C	at 60°C	at 70°C
<b>VG 16</b>	9,4	5,6	3,3 cSt
<b>VG 22</b>	15	11	8 cSt
<b>VG 32</b>	21	15	11 cSt
<b>VG 46</b>	29	20	14 cSt
<b>VG 68</b>	43	29	20 cSt
<b>VG 120</b>	68	44	31 cSt
<b>VG 220</b>	126	77	51 cSt
<b>VG 320</b>	180	108	69 cSt

### Correction factor k(visc)

viscosity (cSt)	k(visc)	viscosity (cSt)	k(visc)
10	0,6	60	1,6
20	0,8	80	2,1
30	1,0	100	2,7
40	1,2	150	4,2
50	1,4		

### Determine of real pressure loss:

1. Select in graph the  $\Delta p$  at Q of a chosen cooler type
2. Determine real viscosity from temperature/viscosity table
3. Take correction factor k(visc) according to real viscosity and multiply with  $\Delta p$  in bar

## Performance Curves BLK Size 1 to 6

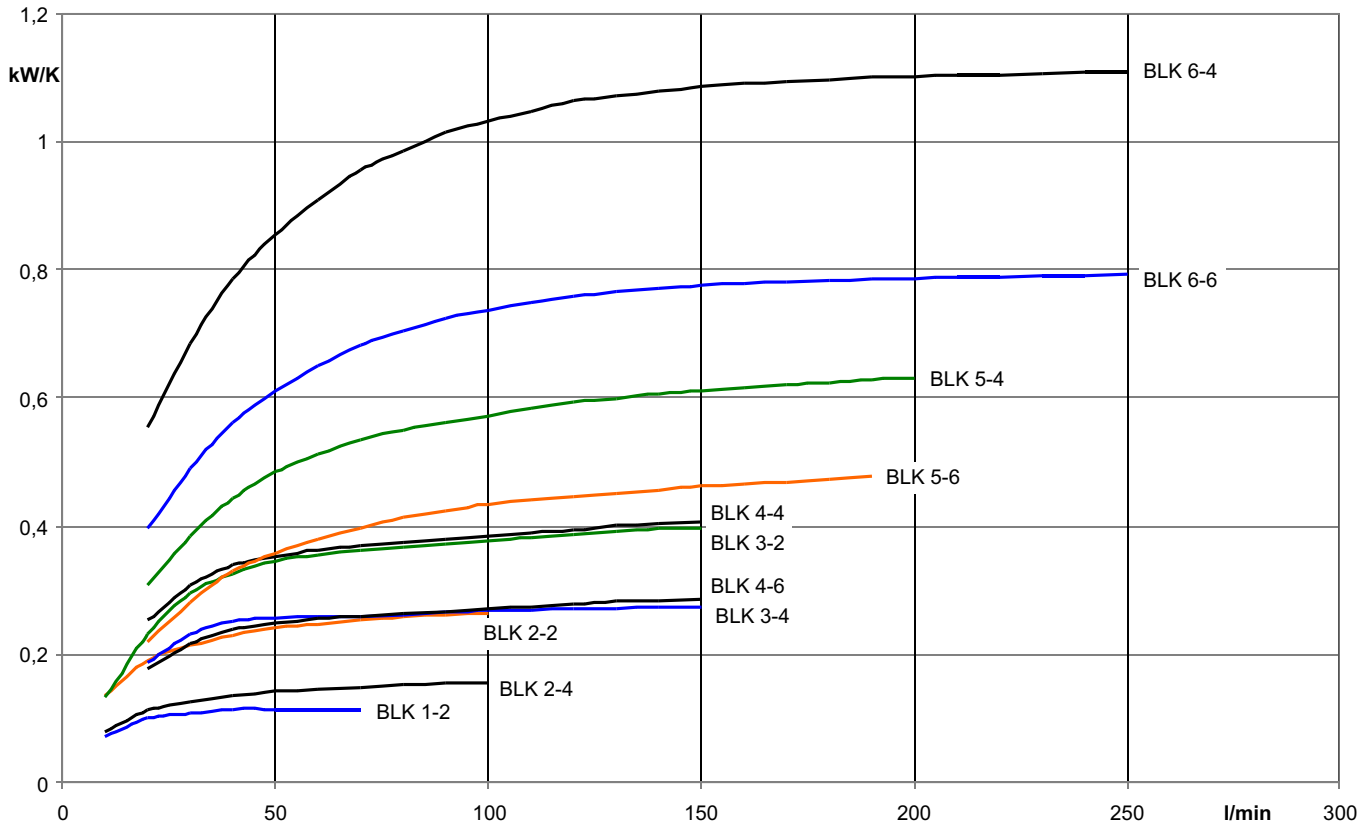

## Performance Curves BLK Size 7 to 10

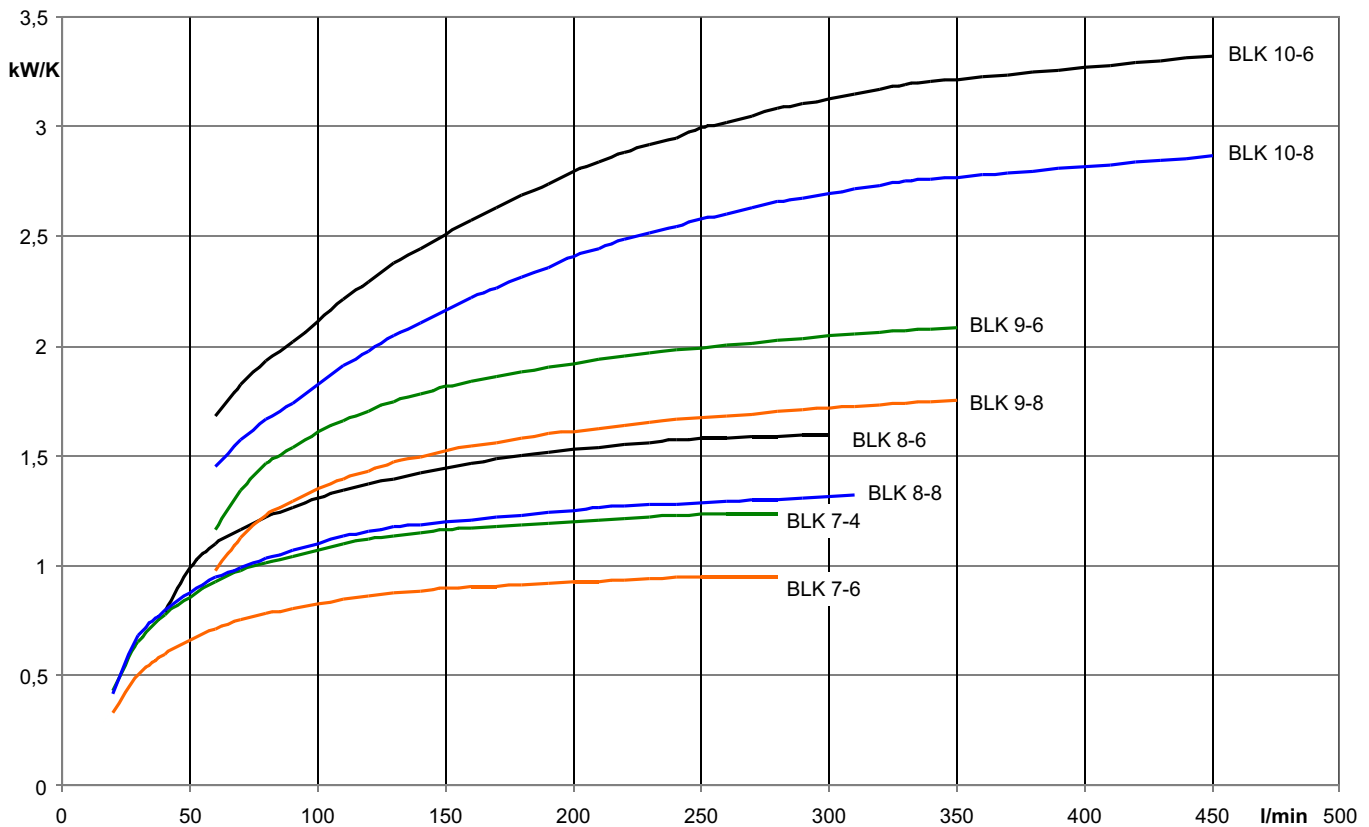

## General Data

### Material / surface protection

Cooling matrix aluminium, varnished  
 Fan case, finger guard and motor console mild steel powder coated

**Colour** RAL 7001

### Fluids

Mineral oil according to DIN 51524  
 Oil/water emulsion HFA /HFB according to CETOP RP 77 H  
 Water glycol HFC according to CETOP RF 77 H  
 Phosphate ester HFD-R according to CETOP RP 77 H

### Operating pressure

static max. 21 bar

### Operating temperature

Media max. 120°C  
**Max. viscosity** 100 cSt average viscosity, higher viscosities upon request

### Electrical motors

(others on demand):  
 Voltage  
 BLK 1.2 230 V 50Hz  
 BLK 2.2 - BLK 10.8 230 / 400 V 50Hz ± 5%  
 276 / 480 V 60Hz ± 5%  
 Insulation class F  
 Rise in temperature B  
 Protection class IP 55  
 Design according to IEC 34-1, IEC 72-1, DIN 57530, VDE 0530

## Basic Data (at 50 Hz)

Part no.	Type	Motor power output	Full load current at 400V	Motor poles	Weight (kg)	Volume (l)	Noise emission db(A)*
3501200	BLK 1.2	0,25 kW	0,24A 230V	2	7	0,8	65
3502200	BLK 2.2	0,55 kW	1,42 A	2	23	1,3	81
3502400	BLK 2.4	0,25 kW	0,84 A	4	23	1,3	66
3503200IE2	BLK 3.2	1,1 kW	2,52 A	2	31	1,8	87
3503400	BLK 3.4	0,25 kW	0,84 A	4	28	1,8	71
3504400	BLK 4.4	0,37 kW	1,11 A	4	34	2,3	73
3504600	BLK 4.6	0,18 kW	0,6 A	6	34	2,3	63
3505400IE2	BLK 5.4	0,75 kW	1,8 A	4	45	3,1	79
3505600	BLK 5.6	0,25 kW	0,87 A	6	42	3,1	68
3506410IE2	BLK 6.4	2,2 kW	4,59 A	4	77	4,1	86
3506610	BLK 6.6	0,55 kW	1,65 A	6	60	4,1	74
3507410IE2	BLK 7.4	2,2 kW	4,59 A	4	87	5,4	89
3507610	BLK 7.6	0,55 kW	1,65 A	6	72	5,4	75
3508610IE2	BLK 8.6	1,5 kW	3,3 A	6	95	6,3	79
3508810	BLK 8.8	0,55 kW	1,85 A	8	91	6,3	73
3509610IE2	BLK 9.6	2,2 kW	4,85 A	6	159	8,2	86
3509810	BLK 9.8	1,1 kW	3,2 A	8	155	8,2	79
3510610IE2	BLK 10.6	5,5 kW	11,3 A	6	256	19	90
3510810	BLK 10.8	2,2 kW	5,96 A	8	241	19	84

The part numbers for BLK 2 -5 are 50/60 Hz versions, for BLK 6-10 the 50 Hz versions only, the 60 Hz versions are available upon request.

\* DIN EN ISO 3744, class 3

## Type code

### BLK 4. 6-IBx - T50

number of poles (see table)  
 size (see table)

### BLK 4. 6-IBx - T50

If the by-pass valve or if the temperature switch are needed the following codes have to be added:

By-pass version	<b>AB</b> <b>IBx</b> <b>x</b> <b>ITB</b> <b>ATB</b>	external by-pass integrated by-pass by-pass pressure <b>2; 5 or 8 bar</b> integrated temperature operated by-pass 2 bar / 45°C external temperature operated by-pass 2 bar / 45°C
Temperature switch	<b>T50,T60</b> <b>T70,T80</b>	figures stand for °C, details see separate data sheet

## Dimensions

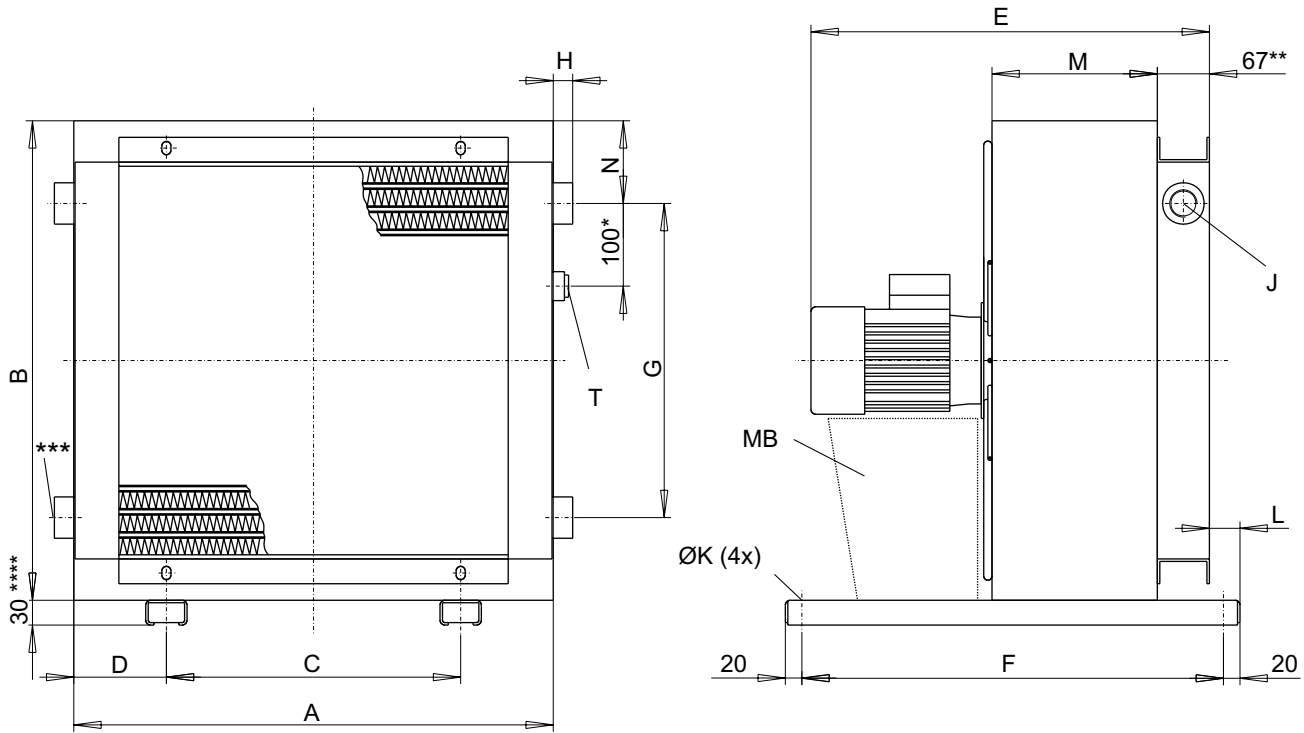

- MB some types have consoles to support motor  
 T connection G ½ for temperature switch  
 connection M14 x1,5 for temperature switch BLK 1  
 \* BLK 9 and 10 = 150 mm  
 \*\* BLK 1 = 45 mm  
 BLK 10 = 94 mm  
 \*\*\* connection only at BLK 9 and 10  
 \*\*\*\* BLK 1 = 15 mm

cooler type	A	B	C	D	E	F	G	H	J	K	L	M	N	MB
BLK 1.2	315	244	190	62,5	144	165	-	-	2x G1/2	7	20	50	33	-
BLK 2.2	370	370	203	83,5	415	510	-	25	2x G1	9	33	125	106	-
BLK 2.4	370	370	203	83,5	415	510	-	25	2x G1	9	33	125	106	-
BLK 3.2	440	440	203	118,5	477	510	230	25	3x G1	9	33	150	105	-
BLK 3.4	440	440	203	118,5	440	510	230	25	3x G1	9	33	150	105	-
BLK 4.4	500	500	203	148,5	465	510	230	25	3x G1	9	33	175	104	-
BLK 4.6	500	500	203	148,5	465	510	230	25	3x G1	9	33	175	104	-
BLK 5.4	580	580	356	112	523	510	305	23,5	3x G1	9	33	200	100	-
BLK 5.6	580	580	356	112	490	510	305	23,5	3x G1	9	33	200	100	-
BLK 6.4	700	700	356	172	605	510	410	9,5	3x G1 1/4	9	33	225	110	x
BLK 6.6	700	700	356	172	545	510	410	9,5	3x G1 1/4	9	33	225	110	x
BLK 7.4	700	840	356	172	630	510	590	9,5	3x G1 1/4	9	33	250	91	x
BLK 7.6	700	840	356	172	570	510	590	9,5	3x G1 1/4	9	33	250	91	x
BLK 8.6	870	870	508	181	644	510	585	11	3x G1 1/4	12	33	275	101,5	x
BLK 8.8	870	870	508	181	620	510	585	11	3x G1 1/4	12	33	275	101,5	x
BLK 9.6	1010	1020	518	246	713	510	822	3	4x G1 1/2	12	78	300	99	x
BLK 9.8	1010	1020	518	246	693	510	822	3	4x G1 1/2	12	73	300	99	x
BLK 10.6	1185	1185	600	292,5	830	910	940	5	4x SAE 2 1/2"	12	73	325	130	x
BLK 10.8	1185	1185	600	292,5	858	910	940	5	4x SAE 2 1/2"	12	73	325	130	x

Connection BLK 10 = SAE 2 ½" flange - 3000 psi



# Function Schemes

## Standard BLK 2

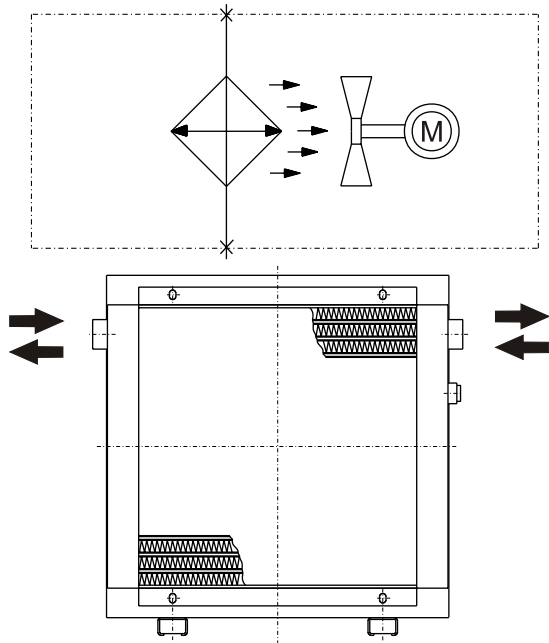

Flow direction optional from left to right or vice versa.

## Standard BLK 1/3 to BLK 10

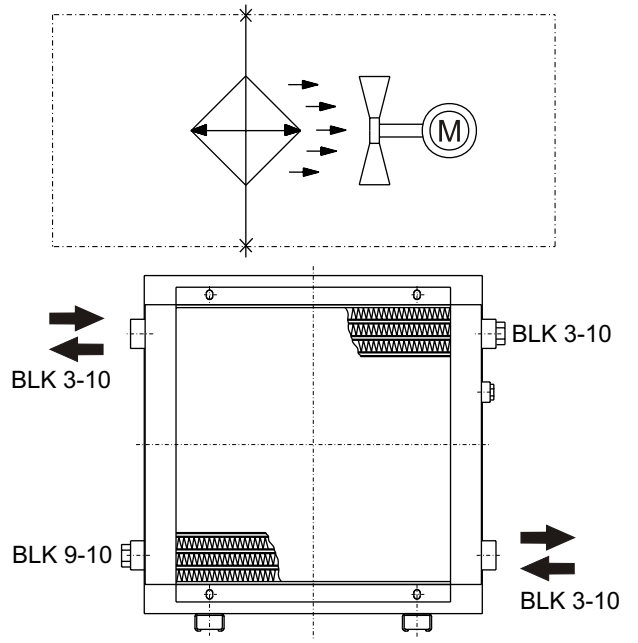

Flow direction optional from high left to low right or vice versa. Other ports must be plugged.

## Internal by-pass IB/ITB (BLK 3-10)

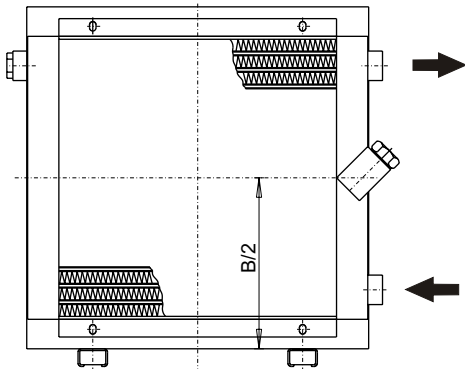

Oil inlet and outlet are always at the same side. Ports on opposite side must be plugged.

## With by-pass valve

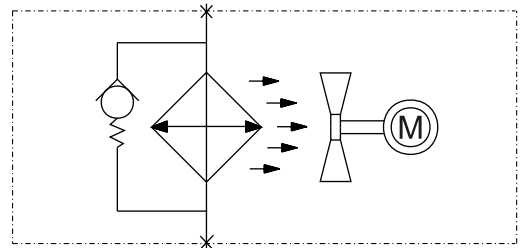

## With temperature operated by-pass valve

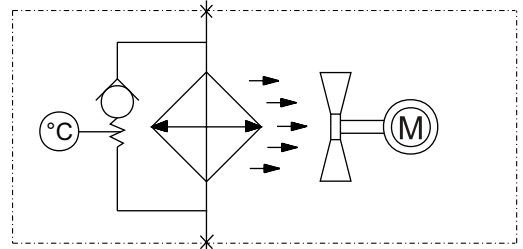

## External by-pass AB/ATB (BLK 2-10)

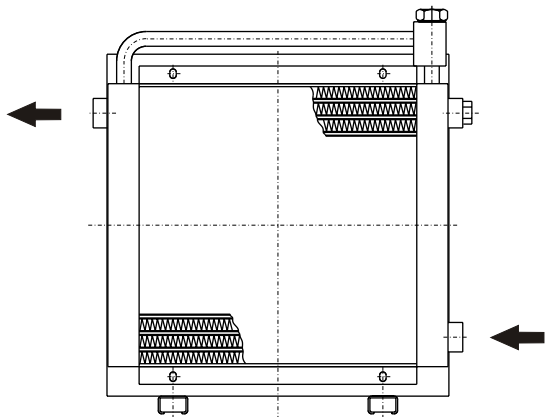

Oil inlet is always from low port, outlet on opposite side. Other ports must be plugged.

## With temperature switch

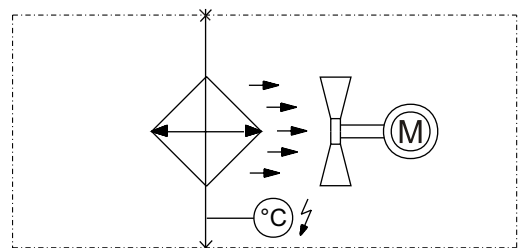

## Installation

### Location

The cooler must be located in such a way that the air flowing through the matrix has free flow on entry and exit. The distance between air intake or air outlet to the nearest surrounding obstacle should be a minimum of half the height of the matrix (dimension B). Free air flow must be provided. If the cooler is to be sited near to working personnel the effect of hot draught and noise emissions must be taken into account.

If the ambient air is carrying impurities or other particulates the cooling matrix could become clogged thus reducing the cooling efficiency. If this situation is unavoidable we recommend cleaning the matrix on a regular basis (see operation manual).

If the cooler is located in open air the motors must be weather shielded.

Always provide good accessibility for inspection or maintenance.

### Mounting

The BLK's are mounted with four bolts through their mounting feet to an adequate support structure. The cooler can be mounted over head or to walls with no restriction.

### Connection of oil circuit

The connections from the cooler to the system should be stress and vibration free. The use of flexible hoses is highly recommended. Please comply with local safety requirements and avoid any risk to the environment from oil spills etc.

## The series BLK is a product designed by BÜHLER company

### The company

BÜHLER TECHNOLOGIES GmbH, Ratingen was founded in 1969.

BÜHLER's corporate philosophy is to offer products and solutions representative of the state of the art.

BÜHLER also specialises in producing level and temperature measuring equipment, particularly for the fluid power industry.



### The products

Our commitment to customers has given rise to a production program which comprises specialized products for fluid technology.

Although these products were initially developed entirely as specials many of them have now become industry standards.

### Bühler quality

Bühler has achieved accreditation from Lloyd's register to be in compliance with ISO 9001 and therefore consider it our obligation to offer our customers not only excellent products, but also the best service possible.

We reserve the right to amend specification