

ZT-2100™

Zero Turn Hydrostatic Transaxle

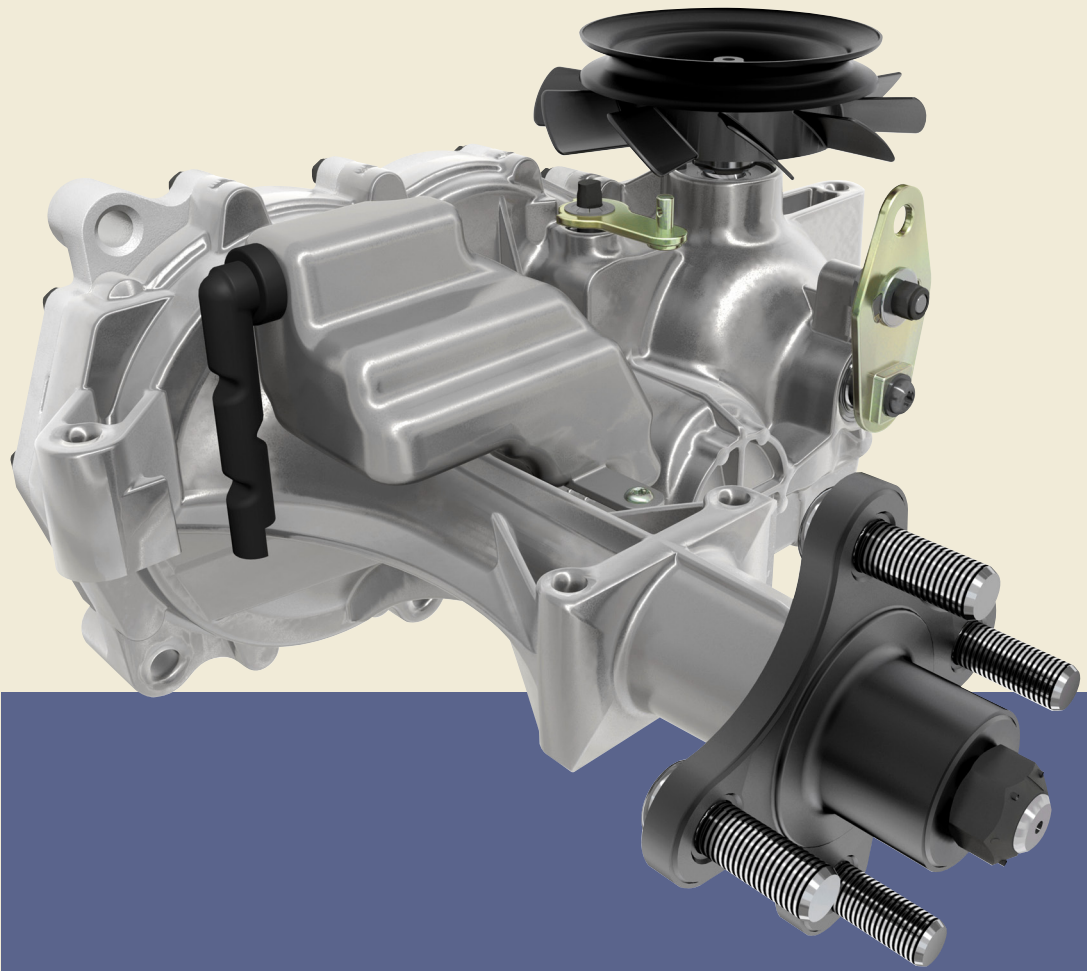

FORWARD MOTION THROUGH FORWARD THINKING®

 **HYDRO-GEAR®**
FORWARD MOTION THROUGH FORWARD THINKING

ZT-2100™

Zero Turn Hydrostatic Transaxle

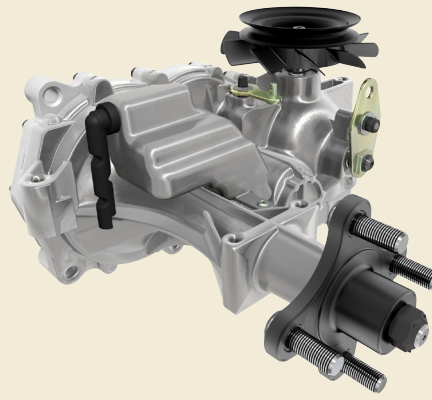

- Outboard mounted control arm
- Inboard mounted brake
- Bypass mechanism
- Speed and directional control
- Return to Neutral option
- External expansion tank for cool operation
- Industry leading warranty and service support

SPECIFICATIONS		ZT-2100
Overall Transaxle Reduction		19.2:1
Input Speeds		
Maximum Hi-Idle [No Load]	rpm	3000
Minimum [Loaded]	rpm	1800
Output Torque		
Continuous	lb-ft [Nm]	105 [142]
Intermittent	lb-ft [Nm]	140 [190]
Weight on Tires (per unit)		
Maximum with 18" tires	lb [kg]	315 [143]
Axle Shaft Diameter	in [mm]	0.75 [19.05]
Axle Shaft End Options	Type:	Tapered 4-Bolt Flange
Parking Brake Type		External Cog
Weight of Unit	lb [kg]	29 [13]



Specifications subject to change without notice.

BLN-0053
10/2010



A World Leader in Hydrostatic Transaxles * Axial Piston Pumps & Motors * LSHT Wheel Motors * Electric L&G Systems
1411 South Hamilton Street * Sullivan, IL 61951 * Phone (217) 728-2581 * Fax (217) 728-7665 * www.hydro-gear.com