

Smart Camera

FHV7 Series

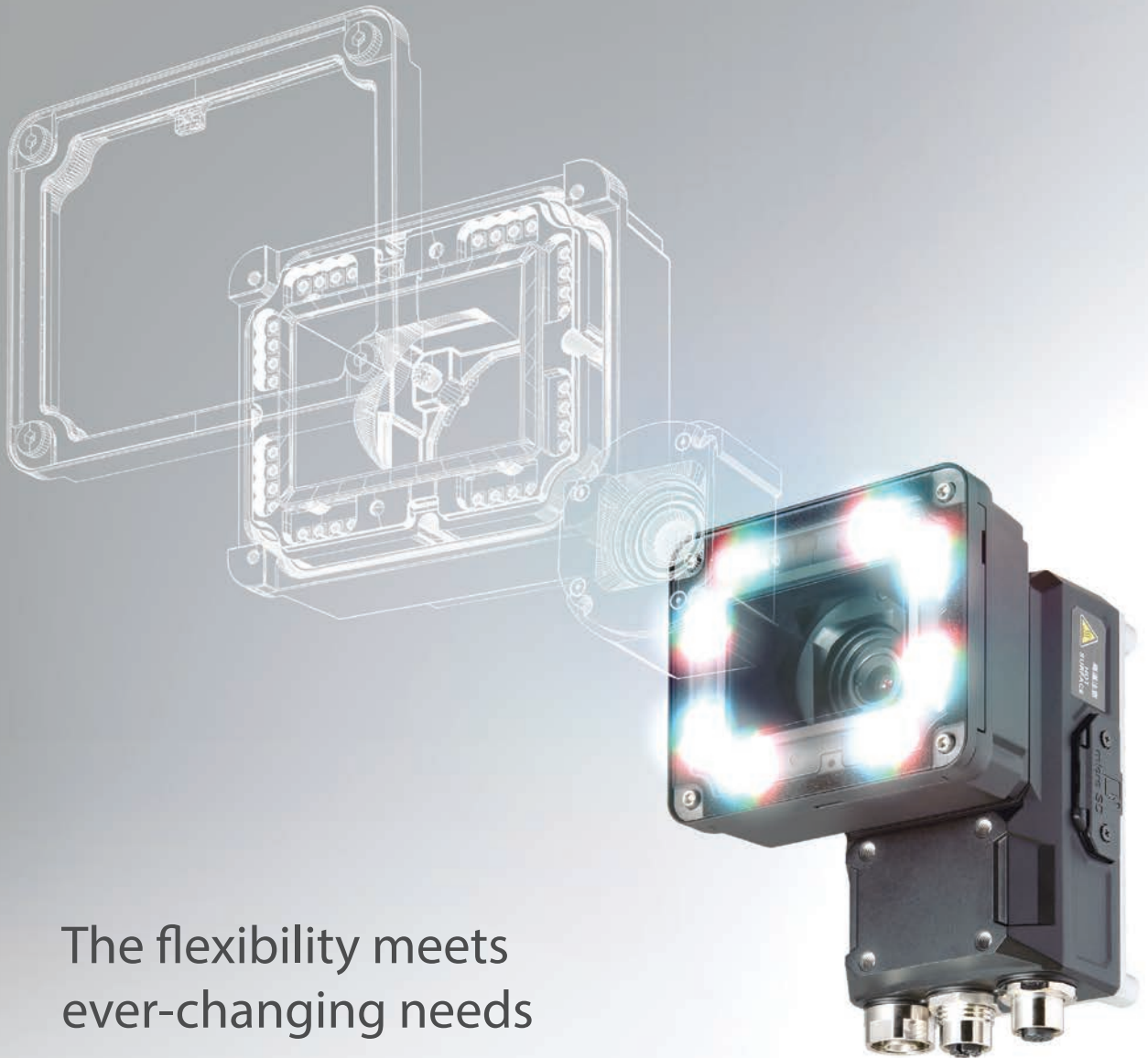

The flexibility meets
ever-changing needs

Ultimate flexibility to fit ever-changing production scene

Nearly-infinite combination to
fit any production scenes P.4

Modular structure

The FHV7 Smart Camera allows you to flexibly combine a lens, light and image element, which are the important modules that determine the performance of a smart camera.

You can integrate multiple vision sensors installed at your production line into this FHV7 Smart Camera, which can be customized to meet your inspection and measurement needs.

By managing inventory of cameras based on modules, you can significantly reduce costs.



Single camera for inspecting various products P.6

Multi-color Light, Autofocus Lens, 12 Mpix

Like human eyes, the FHV7 Smart Camera with the multi-color light and autofocus lens stably measures objects in different colors and sizes on the same production line.

The illuminating colors and lens focuses can be adjusted by parameters, so the mechanism for replacing lights and moving cameras is no longer necessary. This feature greatly reduces the time required for design and adjustment and the number of machine components.

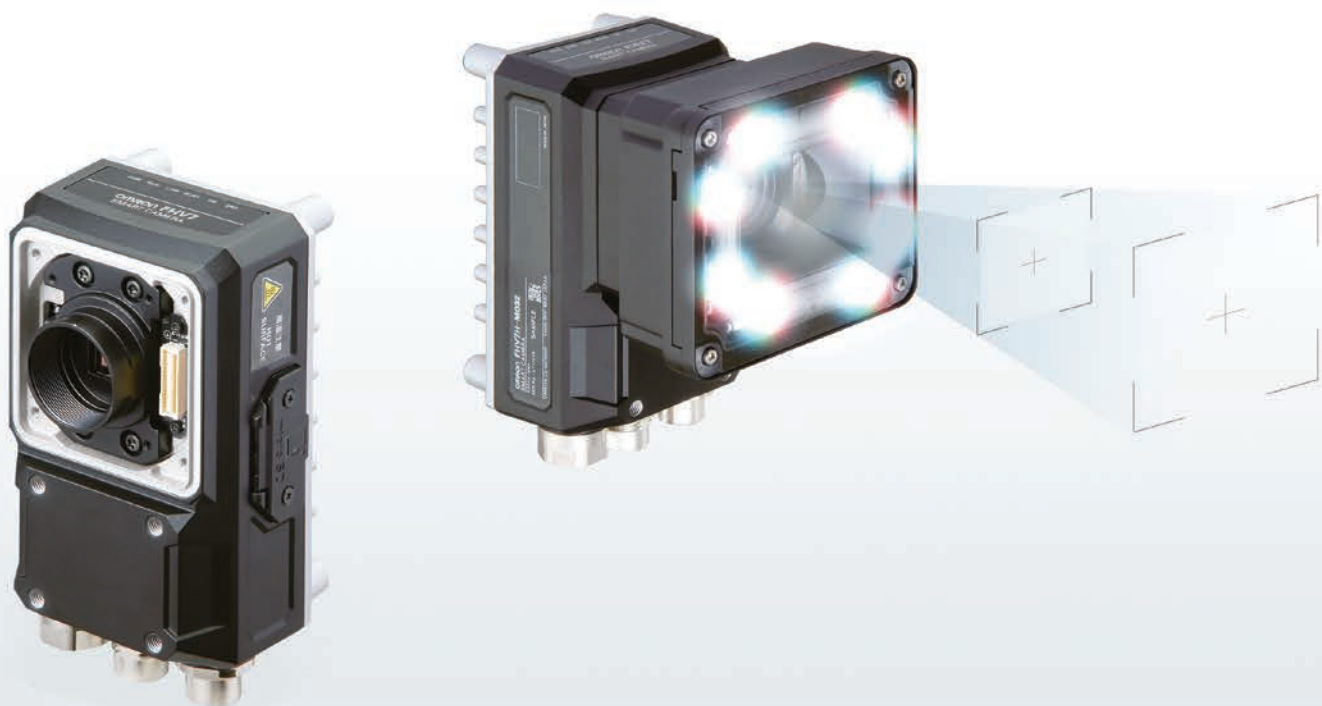

Raising production quality without sacrificing cycle time P.8

Best-in-class speed *1

The inspection time can be reduced to 1/4 *2 of that required for existing models. This FHV7 Smart Camera enables you to keep the same cycle time even after you upgrade resolution or add inspection points.



*1. Based on Omron investigation in October 2018.

*2. Sample comparison to inspection time using vision sensors installed in customer's machine. Based on Omron investigation in October 2018.

Nearly-infinite combination to fit any production

Smart Camera



**PROFI
NET**
EtherNet/IP
Ethernet

Lenses



Autofocus lens
6/9/12/16/25 mm



C mount lenses (examples)

Image sensors (color/monochrome)

Global shutter

0.4 Mpix	1.6 Mpix
3.2 Mpix	5 Mpix

Rolling shutter

6.3 Mpix	12 Mpix
----------	---------

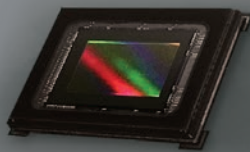

Waterproof hood

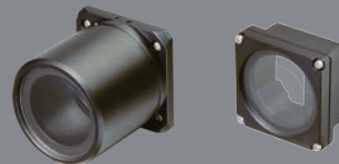

This component is required to ensure IP67 protection without using a lighting module.

IP67 structure

Maintains IP67 waterproof structure even after module replacement, allowing use in wet conditions.



Captive screws

Captive screws are used in the modules. The screws do not drop on products.



scenes

The FHV7 Smart Camera provides several options for components, allowing you to freely combine the lens and light with the camera and easily adjust the optical conditions to specific products. The footprint of the camera is not affected by module replacement. Even if a sudden change occurs in the product specification, the system can be ready after minimum rearrangement.

An all-in-one models with lens modules and light modules are also available.

Modules

Lights



Multi-color (R/G/B/IR)



Red



IR

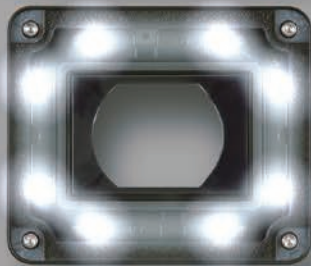

White

Easy connection with FLV/FL External Lights

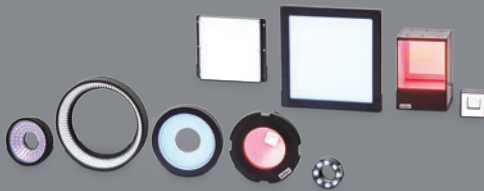

You can select from a broad lineup of more than 150 models.

Optical Filters



Diffusion filter



Polarization filter (visible light)



Polarization filter (infrared and visible light)

Easy addition of external lights

By connecting the lighting controller, you can, from FHV7's setting window, easily adjust the light emission intensity and set light emissions to synchronize with the release of the shutter.



Lighting Controller

Easy filter replacement

The light cover and optical filter are replaceable, so you don't need to prepare a protection cover against dirt.



Dirty cover filters can be removed separately for replacement

Single camera for inspecting various products



Multi-color Light

Accommodates color variations

Multi-color light provides a quick solution to the issue of measuring different colors. For example, objects with variously colored packages on a production line are properly measured with the light that changes its illumination color to fit each object. When the product design is changed or a new model is added, you can simply change a parameter instead of replacing or fine-tuning lights. The production line is always ready for a wider variety of product.

Autofocus Lens

Accommodates size variations

The autofocus lens covers a focal length range from 59 mm to 2,000 mm^{*1}. Even when products in different sizes are produced, the focus range can be changed easily by parameters.^{*2} This feature eliminates mechanical operation for changeover during product replacement, leading to a simpler system with higher productivity.

*1. Differs depending on the lens type. See the optical chart on page 35 for details.

*2. Set focuses for different product heights in advance and switch between them when you perform a changeover.

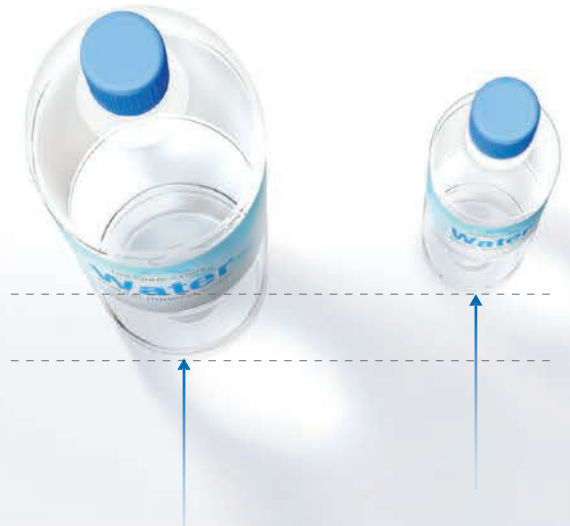

Best-in-class resolution^{*3}: 12 megapixels

Location variation

The image sensor with a 12 megapixels enables high-precision inspections for wider areas. This eliminates the need for installing multiple cameras or a mechanism to move a camera to capture different inspection points on different models on the same production line.

*3. Based on Omron investigation in October 2018.



When inspecting products of different colors

As a product has more color options, some of the colors may cause low contrast under a single color illumination. The multi-color illumination allows switching colors for different product color options, ensuring stable inspections.

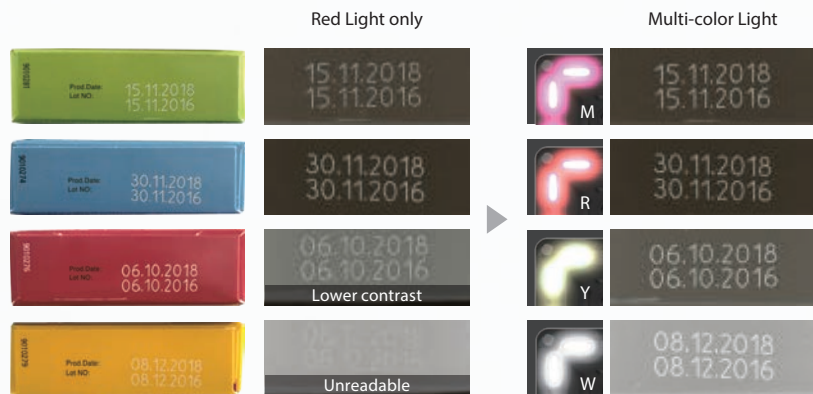

When inspecting products of different sizes

When inspecting products such as plastic bottles that come in different sizes, you can perform a changeover only by switching the setting of the autofocus lens. The autofocus lens does not need the mechanism for moving the camera.



Expanding the range of parts inspection

Accurate and extensive inspection of parts mounting points on different automobile models is enabled without moving cameras.



Raising production quality without sacrificing cycle time



Inspection time reduced to 1/4 ^{*1}

Time required for external inspection of cans ^{*1}



The inspection time can be reduced to 1/4 ^{*1} of that required for existing sensors. You can carry out more precise, detailed quality inspection while keeping the same cycle time.

Clear images facilitate inspection

Precise inspection with high-resolution images is possible while keeping the same cycle time as before. The FHV7 Smart Camera raises production quality with its ability to detect tiny tears or scratches on labels, which could not be previously detected.

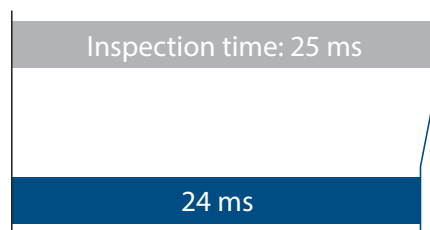
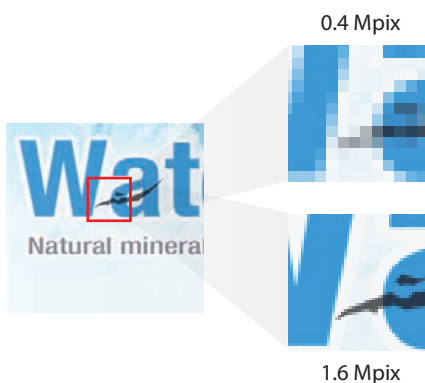

Shorter inspection time even when the number of pixels is increased

More inspection points

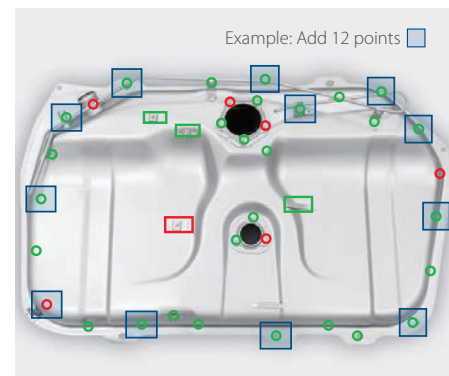

Green: Inspection passed, Red: Inspection failed



Best-in-class speed ^{*2}

Image capture: Maximum speed 2.3 ms

×

Distributed processing across 2 cores

×

High-speed algorithm

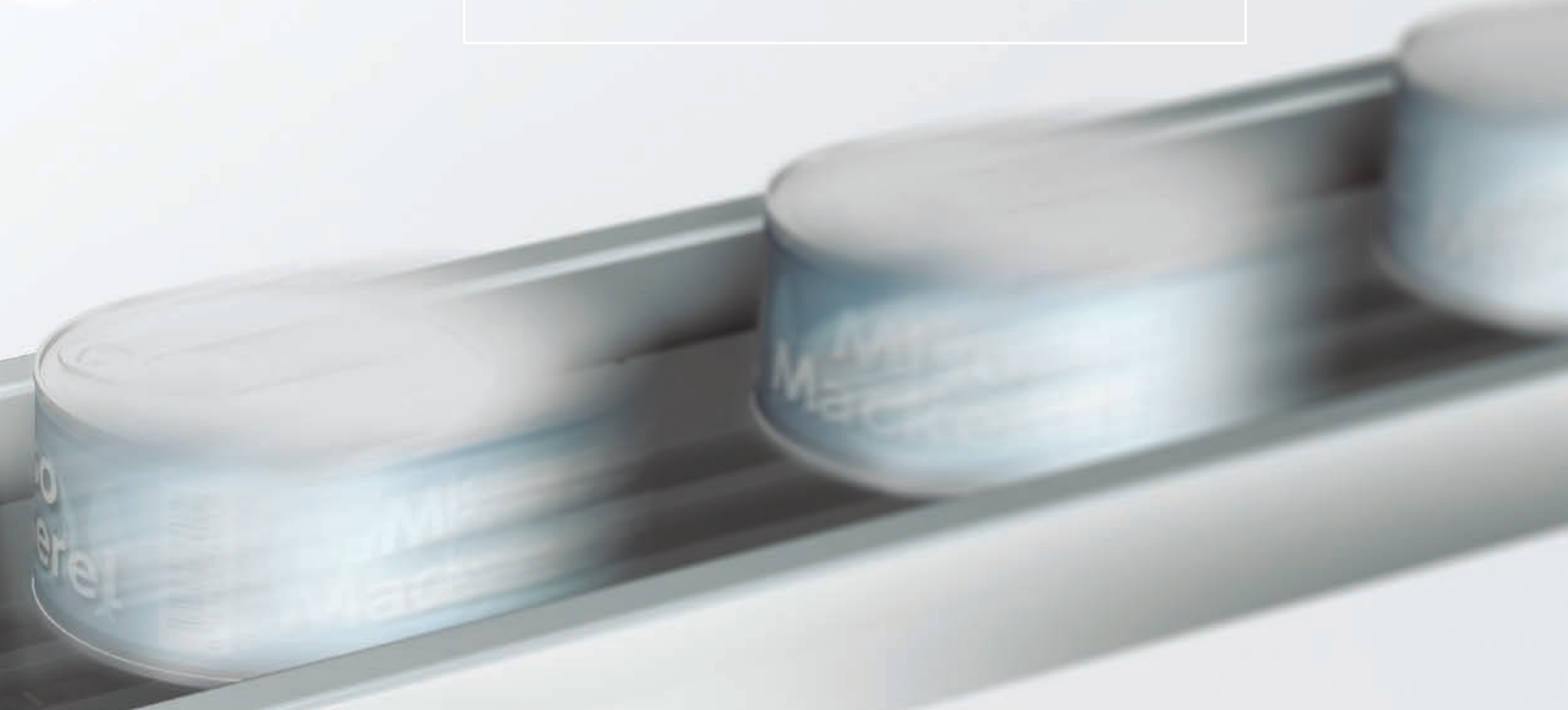

The FHV7 Smart Camera provides an optimal solution for a problem of longer cycle times caused by inspection points added to raise production quality. You don't need to divide the field of view into several parts and assign them to multiple cameras or install a high-speed vision system.

Settings can be adjusted with zero downtime

Measured values may change gradually due to workpiece variation or changes in external circumstance. Even in such cases, distributed processing across 2 cores allows you to perform cause analysis and setting adjustments as you make measurements. You can eliminate downtime and visual inspection of uninspected items.

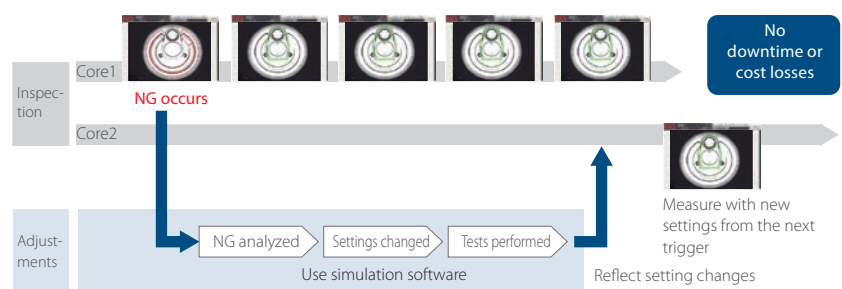
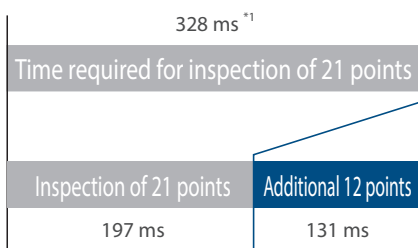

^{*1}. Sample comparison to inspection time using vision sensors installed in customer's machine. Based on Omron investigation in October 2018
^{*2}. Based on Omron investigation in October 2018.

Application Examples

Traceability and serial number management

The FHV7 Smart Camera is suitable for applications in which inspection results and images are managed by product serial numbers.

Stable reading regardless of printing quality

2D Code II delivers powerful code reading

The dedicated algorithm for stable 2D code reading under adverse conditions is implemented. Data based on the print quality specifications can be output, which contributes to stable printing.

Changing ambient brightness

Chips due to reflection Low contrast

After processing/washing

Waterdrops and dirt Scratched damage

Poor printing quality in high-speed line

Variations in start positions

Poor printing quality on coarse surface

Uneven line spacing

Molding variations of forged object

Print Quality Grading Function

- ISO/IEC 15415
- ISO/IEC TR29158

Stable reading of difficult-to-read characters (OCR)

Printed characters can be too close to each other, and characters can be printed on curved surfaces.

Even in these cases, stable reading is possible.

Touching characters

Curved character strings

Easy installation with built-in dictionary

Many previous character reading methods required dictionary setup before usage, which was a tedious step. The built-in dictionary developed through our long and rich experiences on FA sites includes a variety of fonts and possible character variations, eliminating the need of dictionary setup. You can also add non-conventional characters when special fonts are read.

Characters from most printers can be read, including dot and impact printers.

Approx. 80 fonts are supported

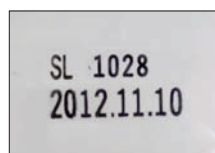

Hot printer



Inkjet printer



Thermal printer

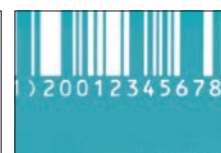

Laser marker

High-speed image storage and image compression

Image data is so large that conventional controllers could not store all images due to limited storage time and storage capacity. The FHV7 Smart Camera has algorithms and hardware that can save images in Omron formats and compress image data at high speed, enabling all images to be stored to meet increasing needs in quality control.

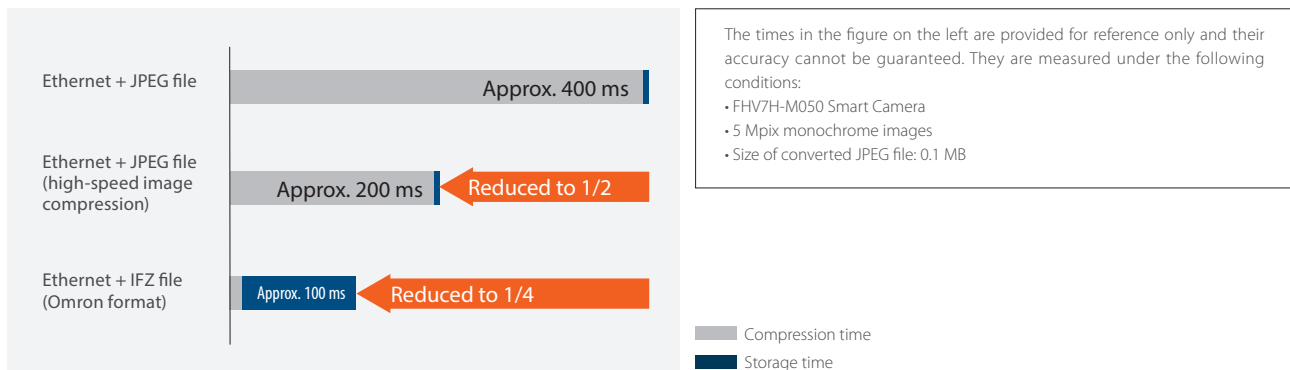

High-speed image storage

Images are saved even during measurements

Distributed processing across 2 cores allows the CPU to perform parallel processing of measurements and image logging. With connection to a high-speed, large-capacity NAS, all images on the high-speed line can be saved, which was previously difficult. * Trend analysis of all saved images quickly isolates errors and facilitates countermeasures.

* All images can be saved under the following conditions:

- One 0.4 Mpix camera
- Measurement time of 30 ms
- JPEG file
- Images can be saved continuously for approx. 380 days when a 3 TB NAS is used (based on 8 hours of operation a day)

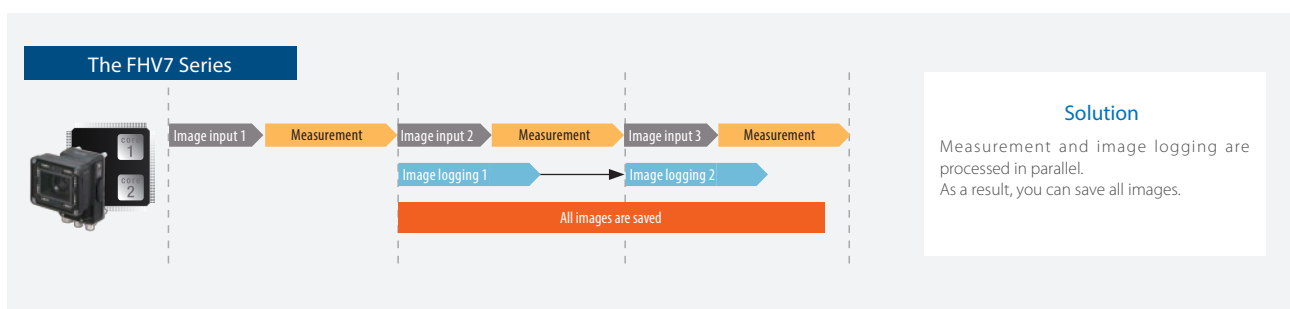
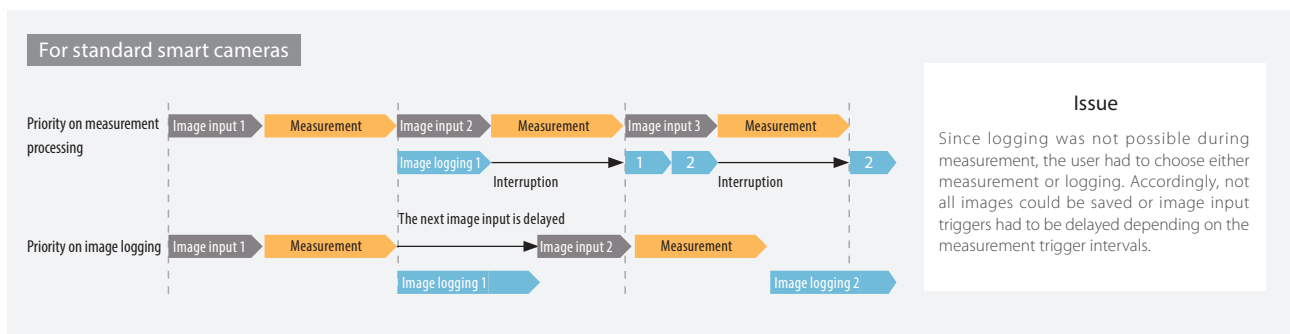

Application Examples

Pick and place

The FHV7 Smart Camera can be combined with robots for picking and assembling applications.

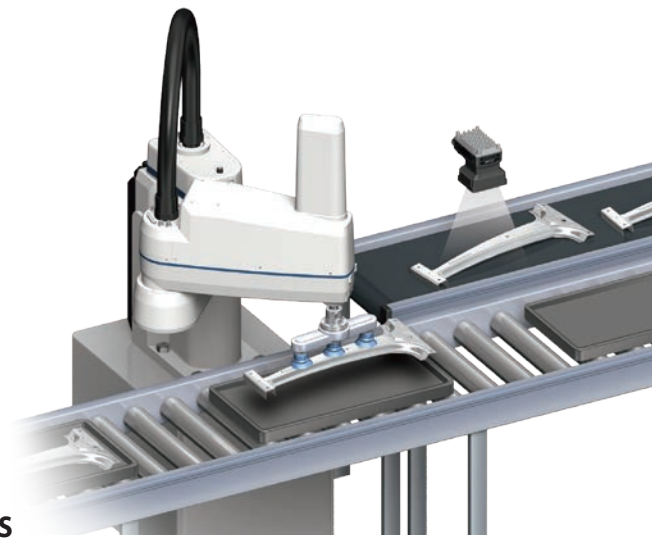

Shape Search III stably detects all types of objects

Stable position detection is performed regardless of shape, material, or background.

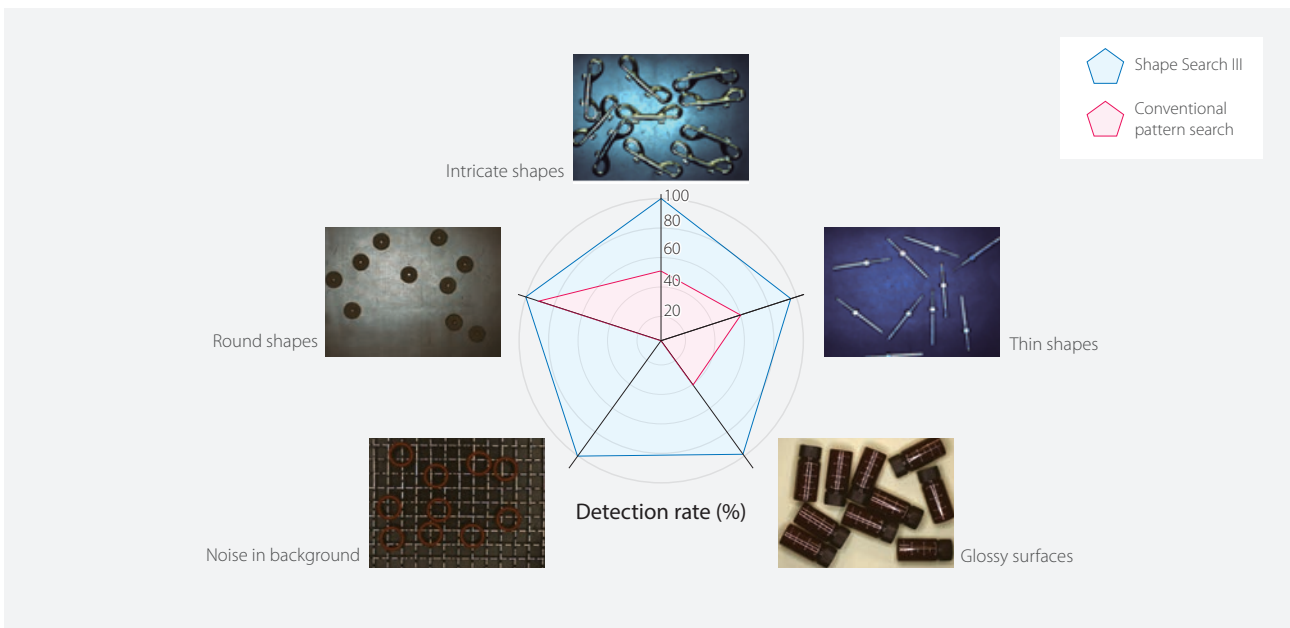

Sorting mixed models

Different types of the searched objects can be sorted.

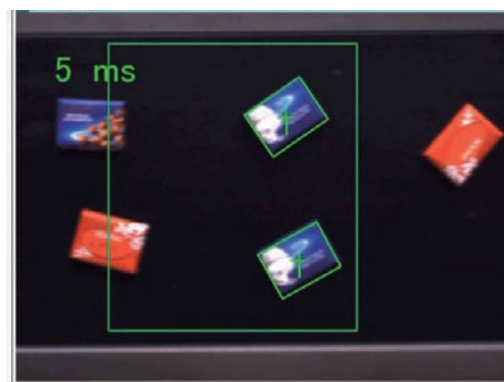

Think & See, the core technology of Shape Search III



"Think & See" is Omron's powerful core technology for image sensing. Omron is continuously developing technologies to measure, detect, or identify the positions, orientations, shapes, materials, colors, status, or attributes of things, people, vehicles, or other objects faster, more precisely, and more easily than the human eye under various conditions.



See the details of Think & See.

<https://www.omron.com/technology/core/thinkAndSee/>

Easy output to major robot manufacturers' devices

The dialog boxes for the FHV7 Smart Camera and the programs for various vendors' robots greatly reduce the set-up time for robot applications. Refer to the system configuration diagram (p. 19) for connection details.

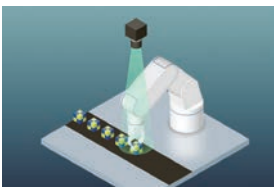

Pick

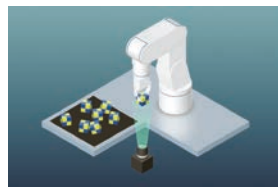

Offset compensation



Place

3-step easy setting

Verified robot communication programs and flowcharts required for robot applications are provided. You don't need to design communications and create a flowchart to set up a robot application.

STEP 1

Obtain robot program and flowchart

Just a few clicks in Robot Setting Tool

Select 3 items to obtain the communication program and flowchart you need.

You can download the Robot Setting Tool from the following URL:
<http://www.ia.omron.com/fhv>

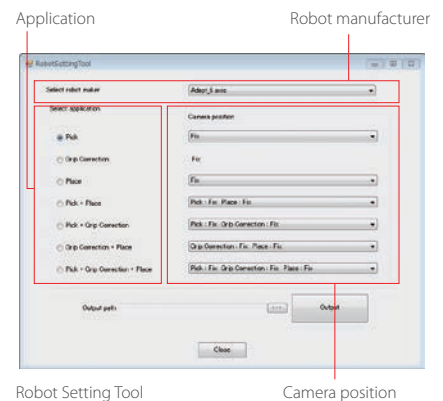

Robot Setting Tool

Camera position

STEP 2

Calibrate

Move robot for calibration from the FHV7 Series

The obtained flowchart can be used to move the robot for calibration from the FHV7 Smart Camera. There is no need to create a program for robot calibration.

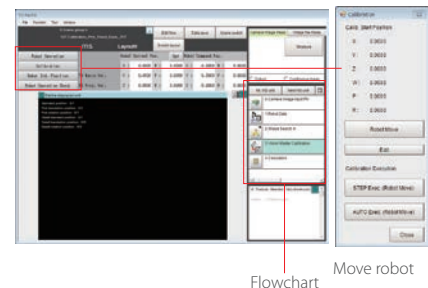

Flowchart

Move robot

STEP 3

Check operations

Set up and check application from the FHV7 Series

Set the coordinates of the robot and check robot operations using the dialog boxes.

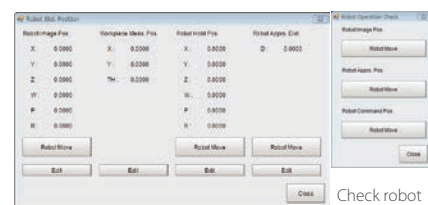

Set the coordinates of the robot

Check robot operations

Filtering to emphasize difficult-to-find defects

Image input & filtering

16
processing
items

Stripe Removal Filter II

The striped pattern is filtered out so that only required aspects are shown clearly. Vertical, horizontal, and diagonal stripes can be removed.



Anti Color Shading

Specific shades that hide defects are removed so that tiny scratches and dirt can be precisely detected. This advanced filtering was achieved through the Real Color Sensing technology.

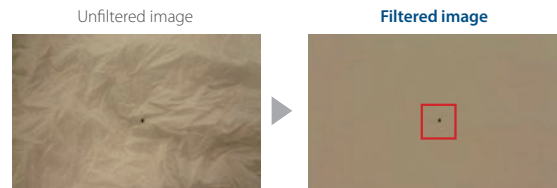

Even Emphasis Unevenness

This filter removes background pattern and enhances low-contrast unevenness.

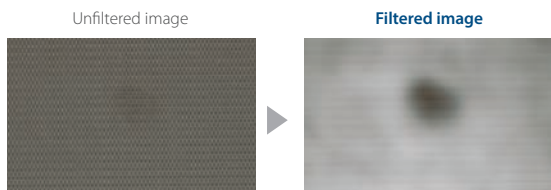

Emphasis Line Defect/Emphasis Circle Defect

These filters enhance defects in high background noise or scratches on embossed surfaces.

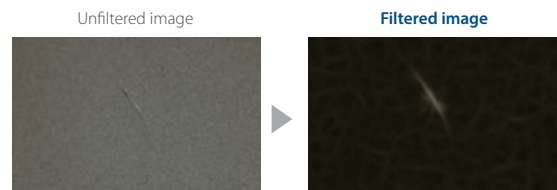

Brightness Correct Filter

This filter cuts out uneven lighting and changes in brightness caused by workpiece surface irregularities to make characteristic features stand out clearly.

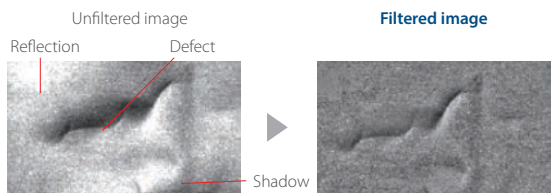

The wavy inconsistencies are judged as defects.

Uneven areas are removed so that only the defect appears in the inspection.

Custom Filter

You can set the mask coefficients as required for these filters. The mask size can be up to 21 x 21. You can flexibly set smoothing, edge extraction, dilation, and erosion for the image.

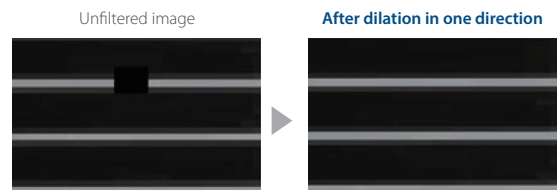

Real Color Sensing PATENTED *

Real-color processing is an image processing technology that performs high-speed processing of full-color images with a total of 16.7 million colors (256 tones per RGB channel). This means that image processing can be performed with the same color information that is visible to the human eye, and stable measurements can be performed under lighting that closely resembles natural light.

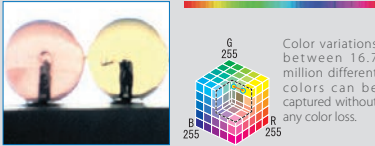
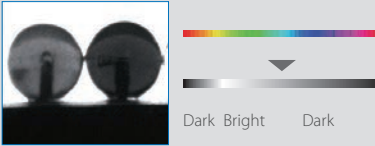
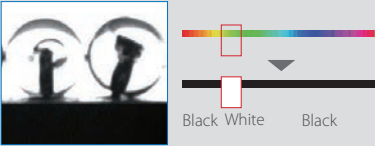
Real Color Sensing	Color image processing	Color segmentation processing
 <p>Color variations between 16.7 million different colors can be captured without any color loss.</p>	 <p>Dark Bright Dark</p>	 <p>Black White Black</p>
<p>The camera image is processed as-is without any loss of quality. This enables even the slightest of color differences to be captured with high accuracy.</p>	<p>Captured images are converted to a 256-shade monochrome image and processed. This enables more stable inspection compared to binary level processing, but slight changes in color cannot be detected with this method.</p>	<p>Captured images are converted to a black and white two-color image and processed. This reduces the amount of data and enables high-speed processing.</p>

* Patent status as of October 2018 US:US9286669, Germany: 602014031613.1, China: ZL201410138793.3, Japan: JP6197340

Processing items for various types of inspections

Inspection & measurement

26
processing
items

Precise Defect

Detection of dirt on paper cups

This processing item is used to detect scratches and dirt on paper cups and molded plastics, as well as oil stains on metal surfaces. Real Color Sensing makes it possible to detect dirt in various colors.

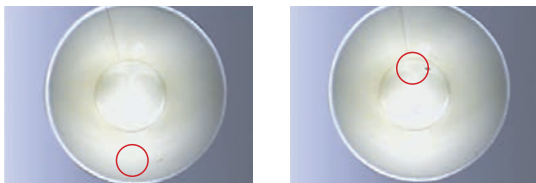

Search

Cable arrangement inspection

Just register a model, and the cable arrangement inspection is completed in one go. Repeating color detection is not necessary.

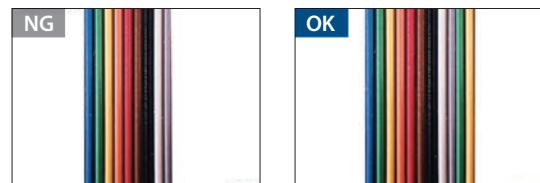

Scan Edge Position and Scan Edge Width

Inspection of groove depth of metal shafts

The maximum and minimum widths within the region are measured simultaneously. This processing item is very useful especially for the measurement of groove depths of metal shafts.

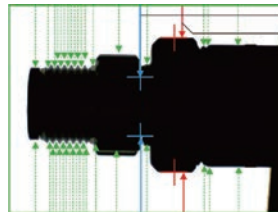

Fine Matching

Inspection for label rips

The registered reference image is compared against the input image and tiny differences are detected at high speed. Scratches on the intricate patterns and unexpected dirt in the color are precisely detected.

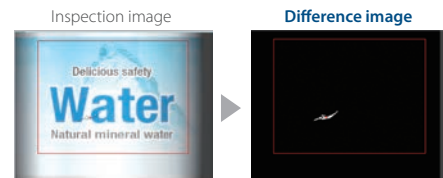

Labeling

Hole counting

The number of labels with the specified color and size is counted. Also, the area and center of gravity of the specified labels are measured.

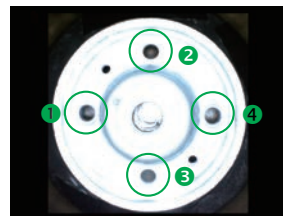

Glue Bead Inspection

Path and width inspection

Just define the start and end points of the object to evaluate sealing numerically. This minimizes inconsistencies in inspection. This method enables accurate inspection of complex curves and interruptions.

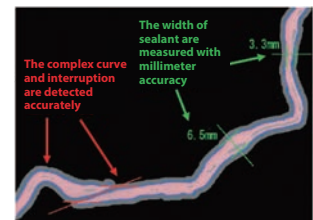

Character Inspection

Label printing inspection

Characters are recognized by pattern search, and this enables special fonts and non-alphanumeric characters to be inspected. Automatically extracting a model and selecting an index from the list help you easily set up your dictionary. Using the user dictionary, the Character Inspection performs pattern search to recognize characters.

Auto model extraction
(Special fonts can be read)



Index selection from list



Easy-to-use system with high functionality

Easy measurement flow creation

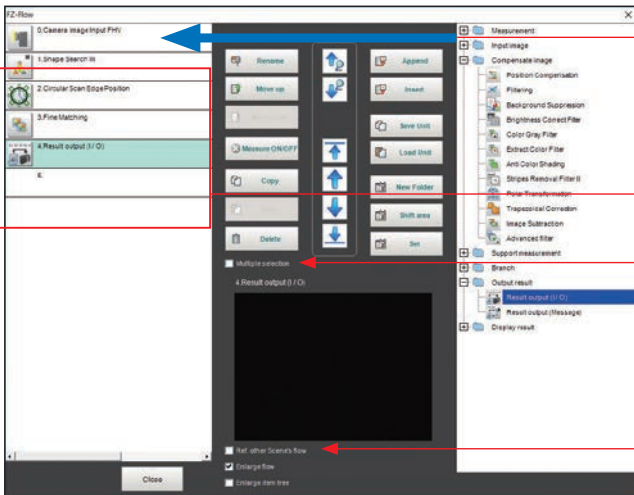

Just drag and drop pre-installed processing items from the processing item list to the flowchart to build a measurement flow.

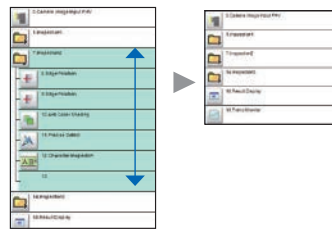

Complex and long processes can be grouped into folders.

Perform different processing items at a time



You can copy or delete two or more processing items at a time by just checking them on the screen.

Copy & paste processing items from other scenes

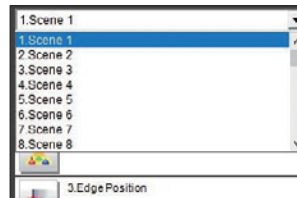

You can set up a new flow menu by combining different processing items copied from other scenes. When reusing the setting of other scenes, you don't need to make adjustments.

Setting and operating from a computer

Use a dedicated software to create measurement flows and measurement conditions. The software can also be used for remote monitoring and control via a network.

You can download the software for free after purchasing the product and signing up online. For details, see the member registration sheet attached to the FHV7 Smart Camera.

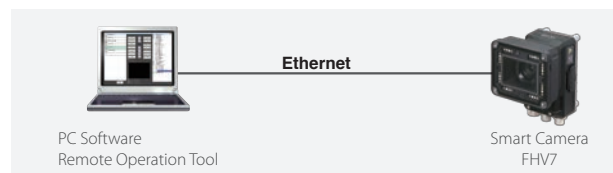

PC Software Remote Operation Tool

Smart Camera FHV7

Simple setting with menus

Total Design Management Editor

The design interface allows you to design complex measurement processes while managing variables. This simple GUI manages complicated branching processes and data sharing across measurement scenes and eliminates the need to switch screens.

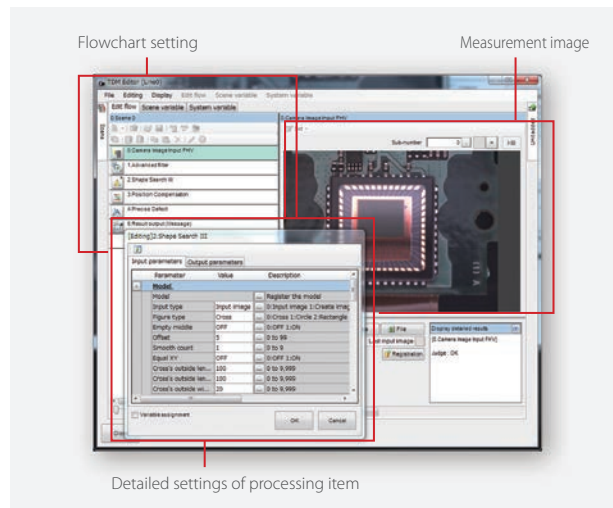

Flowchart setting

Measurement image

Detailed settings of processing item

Customizable user interface prevents incorrect operation

Show only parameters you change everyday

The processing item setting window includes parameters for initial setting and for daily adjustments. To prevent incorrect operation, you can customize the adjustment window to show only parameters that are required for your daily operation.

Example 1: Show only necessary parameters

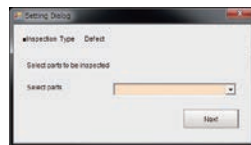

Example 2: Show a wizard



Easy setting

Just select objects from the list in the dialog box and place them. No programming is required.

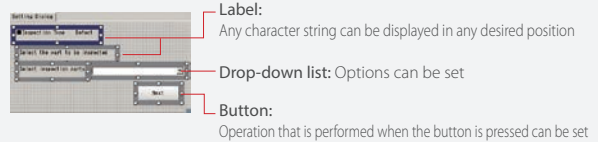

Show only menus you need

Hide unnecessary windows to make operation easy and avoid problems due to incorrect operations.

Customized operation interface

Enlarge the result to see it more easily

The display size can be changed by dragging.



Add short-cut buttons to daily functions

Scene switch	Screen capture	Transfer data
Operation log	Security settings	Scene maintenance
Edit flow	Clear measurement	Data save

Buttons can be added easily from the menu.

Easy connection to field networks

PROFINET, EtherNet/IP

The FHV7 Smart Camera includes communication interfaces for compatibility with a wide range of network protocols used at production sites.

This helps reduce the design work required for data communications between the camera and a PLC.

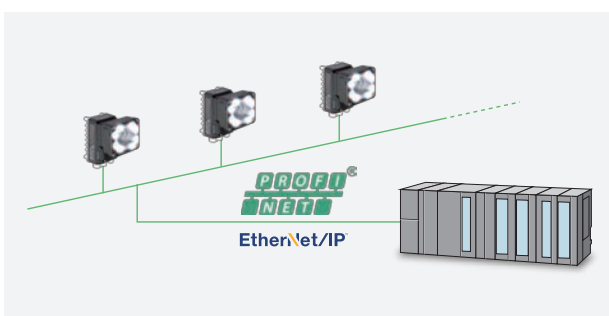

Easy setting of output items





Just select variables to output measurement results.

3.Result output (I / O)

Output setting		Output data		
No.	Offset	Data Type	Data	Value
0	0	Integer	123	
1	4	Double	123.456	
2	12	String	ABCDE	
3				

Product lineup

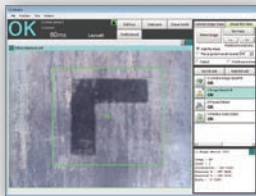
The product lineup includes general-use Smart Cameras and high-speed, high-accuracy vision systems. You can choose the right one according to your requirements for speed and accuracy of each process. Both FH Series and FHV7 Series have the common user interface and operating procedures, so it is possible to share the same image inspection method across the production line. This reduces the time for operator training. The compatibility of setting data enables you to upgrade hardware easily when speed and accuracy enhancement is needed.

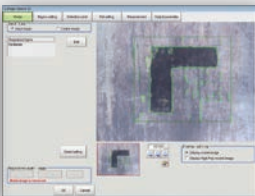
		For various types of inspections			For processes requiring high speed and high resolution					
		Smart Camera FHV7 Series			Vision System FH Series					
										
		FHV7H			FH-2050	FH-5050				
Hardware Grade	Performance ^{*1}	★			★★	★★★				
	No. of cameras	1			8	8				
	Resolution	0.4 Mpix	1.6 Mpix	3.2 Mpix	0.3 Mpix	0.4 Mpix	2 Mpix			
		5 Mpix	6.3 Mpix	12 Mpix	5 Mpix	12 Mpix	24 Mpix			
One Software	Screens	<div style="display: flex; justify-content: space-around;"> <div style="text-align: center;"> <p>Main screen</p>  </div> <div style="text-align: center;"> <p>Measurement flow setting screen</p>  </div> <div style="text-align: center;"> <p>Measurement condition setting screen</p>  </div> </div>								
	Image logging format	<div style="display: flex; justify-content: space-around;"> <div style="border: 1px solid black; padding: 5px; background-color: #555; color: white;">JPEG</div> <div style="border: 1px solid black; padding: 5px; background-color: #555; color: white;">BMP</div> <div style="border: 1px solid black; padding: 5px; background-color: #555; color: white;">IFZ <small>(Omron format)</small></div> </div>								
	Setting data	Compatible ^{*2}								

*1. ★: The more stars, the higher the performance.

*2. Settings for the common functions can be shared between series.

Note: Do not use this document to operate the Unit.

OMRON Corporation Industrial Automation Company
Kyoto, JAPAN

Contact: www.ia.omron.com

Regional Headquarters

OMRON EUROPE B.V.

Wegalaan 67-69, 2132 JD Hoofddorp
The Netherlands
Tel: (31)2356-81-300/Fax: (31)2356-81-388

OMRON ELECTRONICS LLC

2895 Greenspoint Parkway, Suite 200
Hoffman Estates, IL 60169 U.S.A.
Tel: (1) 847-843-7900/Fax: (1) 847-843-7787

OMRON ASIA PACIFIC PTE. LTD.

No. 438A Alexandra Road # 05-05/08 (Lobby 2),
Alexandra Technopark,
Singapore 119967
Tel: (65) 6835-3011/Fax: (65) 6835-2711

OMRON (CHINA) CO., LTD.

Room 2211, Bank of China Tower,
200 Yin Cheng Zhong Road,
PuDong New Area, Shanghai, 200120, China
Tel: (86) 21-5037-2222/Fax: (86) 21-5037-2200

Authorized Distributor:

© OMRON Corporation 2018 All Rights Reserved.
In the interest of product improvement,
specifications are subject to change without notice.

Cat. No. Q264-E1-01

1118 (1118)