

Linear guide lock LMB Series

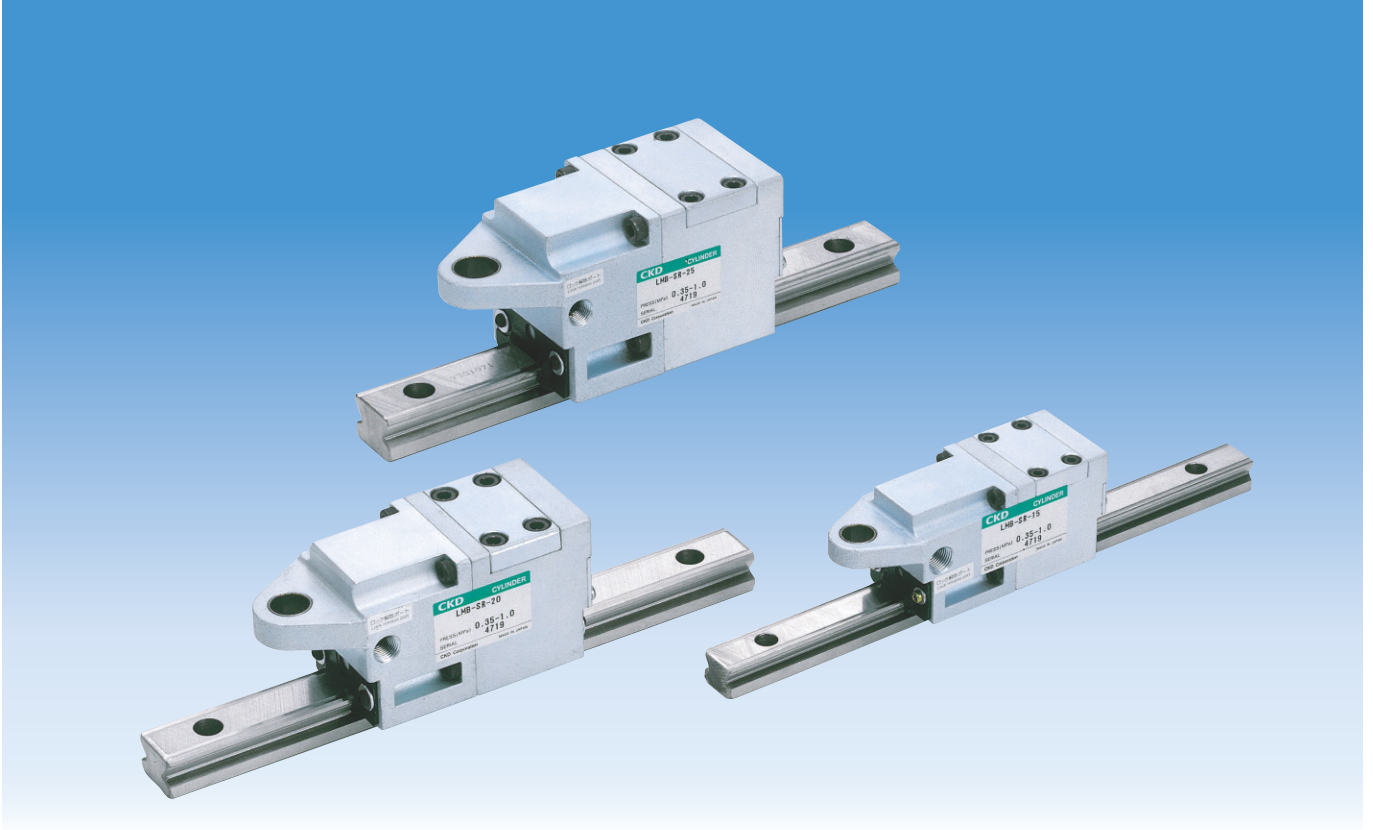

Overview

When used with a system having a linear guide, this lock can be used to lock a workpiece after moving it to a specified position or to enable an emergency stop in a safety situation.

Features

- Compact but powerful holding force
- No backlash when locked
- Unit available for holding when stopped, emergency stop or position locking
- Unlocked by air supply (manual operation possible)
- Dust proof scraper provided as standard before and after lock unit



Read " safety precautions " on the rear page before starting use.

Specifications

Descriptions	LMB-SR-15	LMB-SR-20	LMB-SR-25
Applicable rails	SR-15/SSR-15 THK	SR-20/SSR-20 THK	SR-25/SSR-25 THK
Working fluid	Compressed air		
Max. working pressure MPa	1.0		
Min. working pressure MPa	0.35		
Withstanding pressure MPa	1.5		
Ambient temperature °C	- 5 to 60 °C (to be unfrozen.)		
Lubrication	Not permissible		
Port size	Rc1/8		
Holding force N (note: 1)	1175	1960	2450
Weight g	600	1100	1900

Note: 1: Holding force (max. static load) maintains static load without vibration and shock with unit locked at loadless state.

How to order

LMB-SR - 15

(A) Applicable rail size

Symbol	Descriptions
(A) Applicable rail size	
15	SR-15/SSR-15
20	SR-20/SSR-20
25	SR-25/SSR-25

Operational principle

● When unlocked

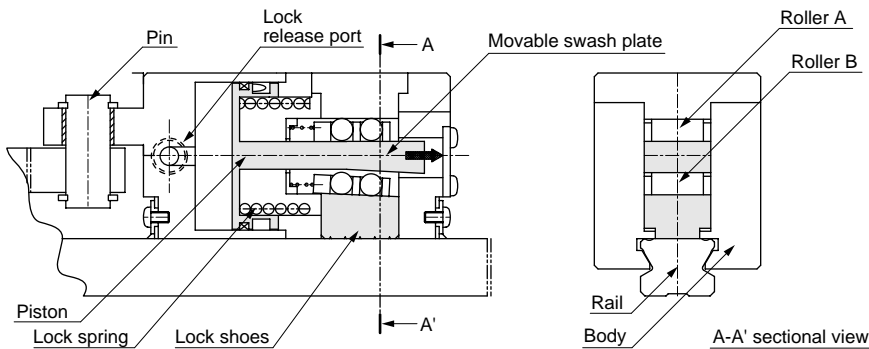

When the lock release port is pressurized with air, the piston and the tapered movable swash plate connected to the piston move in the direction of the arrow, releasing contact between roller B and the movable swash plate.

Pressurizing of the lock shoes against the rail is eased and the lock is released.

● When locked

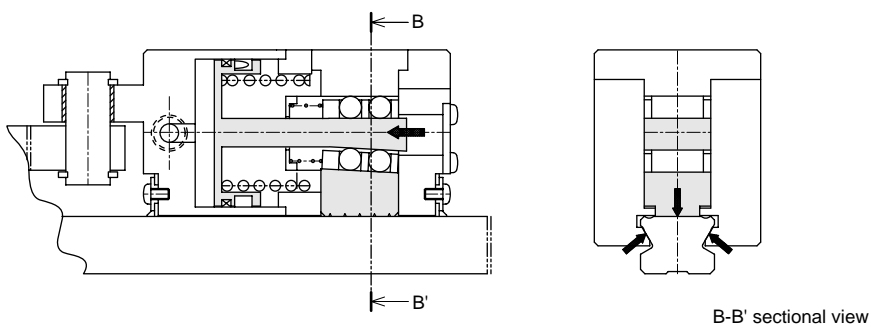

When air is released from the lock release port, the piston and the tapered movable swash plate connected to the piston are moved in the direction of the arrow by the lock spring. The amplification of the taper passes through roller B, causing the lock shoes to press the rail forcibly.

Friction is generated on the rail by three-directional pressurization as shown by arrows in the B-B' sectional view, and the rail is forcibly held.

Dimensions

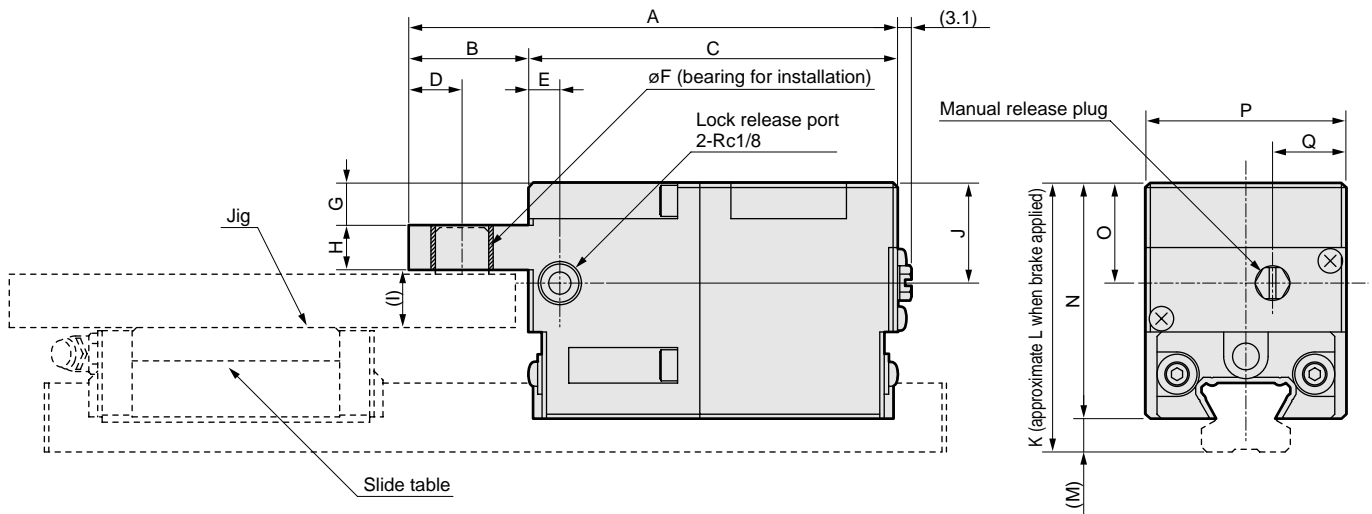

Model no.	A	B	C	D	E	F	G	H	I	J	K	L	M	N	O	P	Q
LMB-SR-15	100	24	76	10	7	10 ^{+0.15} ₀	7	8	8	16.5	47	47.5	6.5	40.5	17.5	35	13
LMB-SR-20	110	27	83	12	7	12 ^{+0.15} ₀	9.5	10	13	22.5	60.5	61	7.5	53	22.5	45	16.5
LMB-SR-25	125	32	93	13.5	7	15 ^{+0.15} ₀	13	10	17	27.5	73	73.5	9	64	27.5	55	19.5

Applications

- Table fixing and position locking

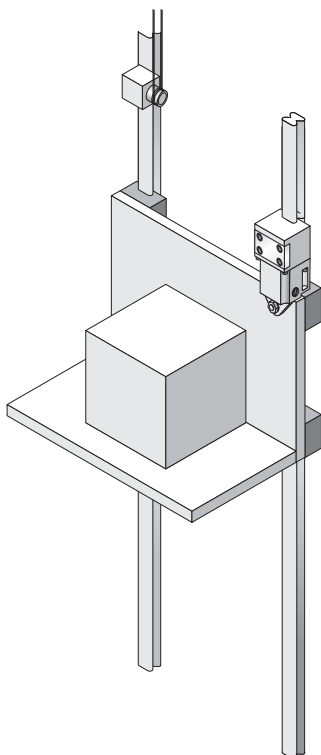

- X-Y table fixing and holding

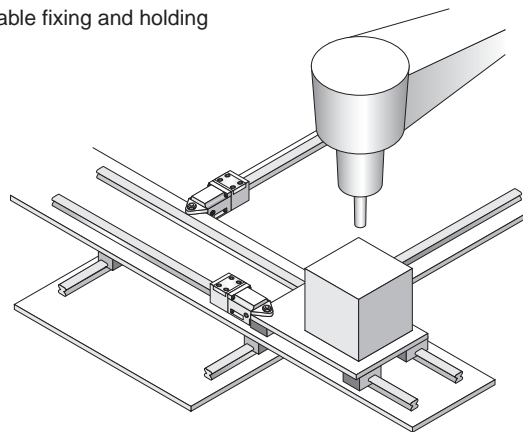

- Table fixing and holding at the desired position

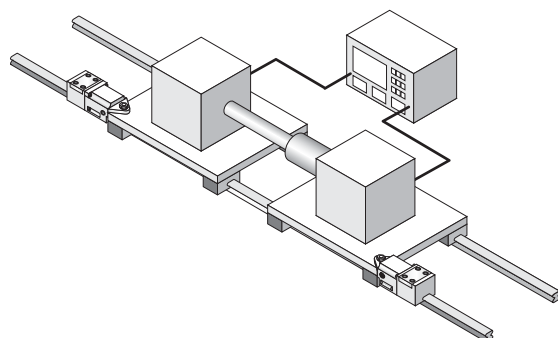

Safety precautions

Caution

Design & Selection

- Consult with CKD if impact load is applied. (The unit could slip by impact.)
- Do not apply lateral load moment to the lock unit.

- Do not use the product in high dust environment or locations that water drip or oil, etc., may contact the product. (Holding force could decrease.)
- Do not put a workpiece on the lock unit directly.

Caution

Installation & Adjustment

How to unlock manually

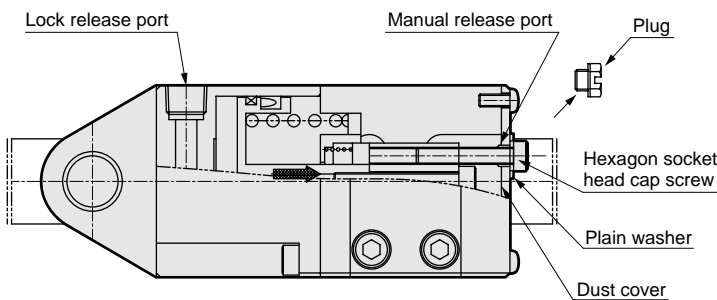

- Confirm that external force is not applied when the lock release port has no air, then disconnect the plug.
- Insert the M3×18 (LMB-SR-15) and M4×22 (LMB-SR-20, 25) hexagon socket head cap screw into the hole from which the plug was removed until threads catch. When inserting the hexagon socket head cap screw, insert a plain washer, and check that the bolt seat does not contact the dust cover.
- Once threads catch, if the screw is screwed in until it no longer moves, the lock will be released and freed.

Note 1) The product is manually released when shipped. Do not lose the hexagon socket head cap screw or plain washer.

Note 2) Do not use a hexagon socket head cap screw exceeding the above size. Threads could be damaged or the lock not be released.

Note 3) If unlocked manually while the seat of the hexagon socket head cap screw and dust cover are in contact, the dust cover could be shaved and dust generated. It may not be possible to screw in the plug, so insert a plain washer and manually release when the screw and dust cover are not in contact.

How to install the product

● Example of rod clevis installation

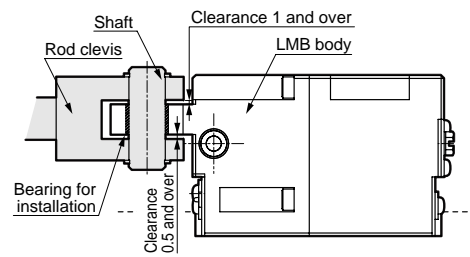

● Example of installation from the top

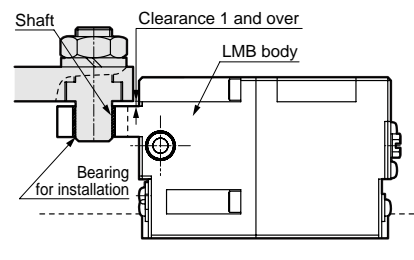

● Example of installation from the bottom

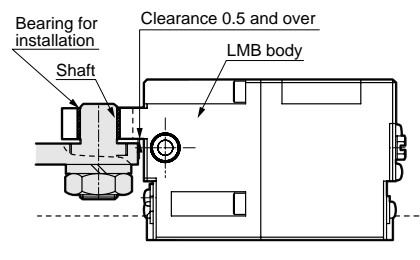

Insert a shaft (pin) into the bearing for installation and connect to the slide table. Provide the clearance shown above. Due to the structure, the LMB moves up and down during locking, so if bearings are fixed without clearance, the lock is not applied.

Warning

During use & Maintenance

- Do not disassemble the lock unit, or could result in a dangerous situation.

If the goods and their replicas, or the technology and software in this catalog are to be exported, laws require the exporter to make sure they will never be used for the development or the manufacture of weapons for mass destruction.