

CKD Linear Slide Series

Used in applications of every kind from assembly to transport and much more

- LCW
- LCR
- LCG
- LCX
- LCM
- STM
- STG
- STS/STL
- STR2
- UCA2
- ULK*
- JSK/M2
- JSG
- JSC3/JSC4
- USSD
- UFCD
- USC
- JSB3
- LMB
- LML
- HCM
- HCA
- LBC
- CAC4
- UCAC2
- CAC-N
- UCAC-N
- RCC2
- RCS
- PCC
- SHC
- MCP
- GLC
- MFC
- BBS
- RRC
- GRC
- RV3*
- NHS
- HR
- LN
- Hand
- Chuk
- MecHnd/Chuk
- ShkAbs
- FJ
- FK
- SpdContr
- Ending

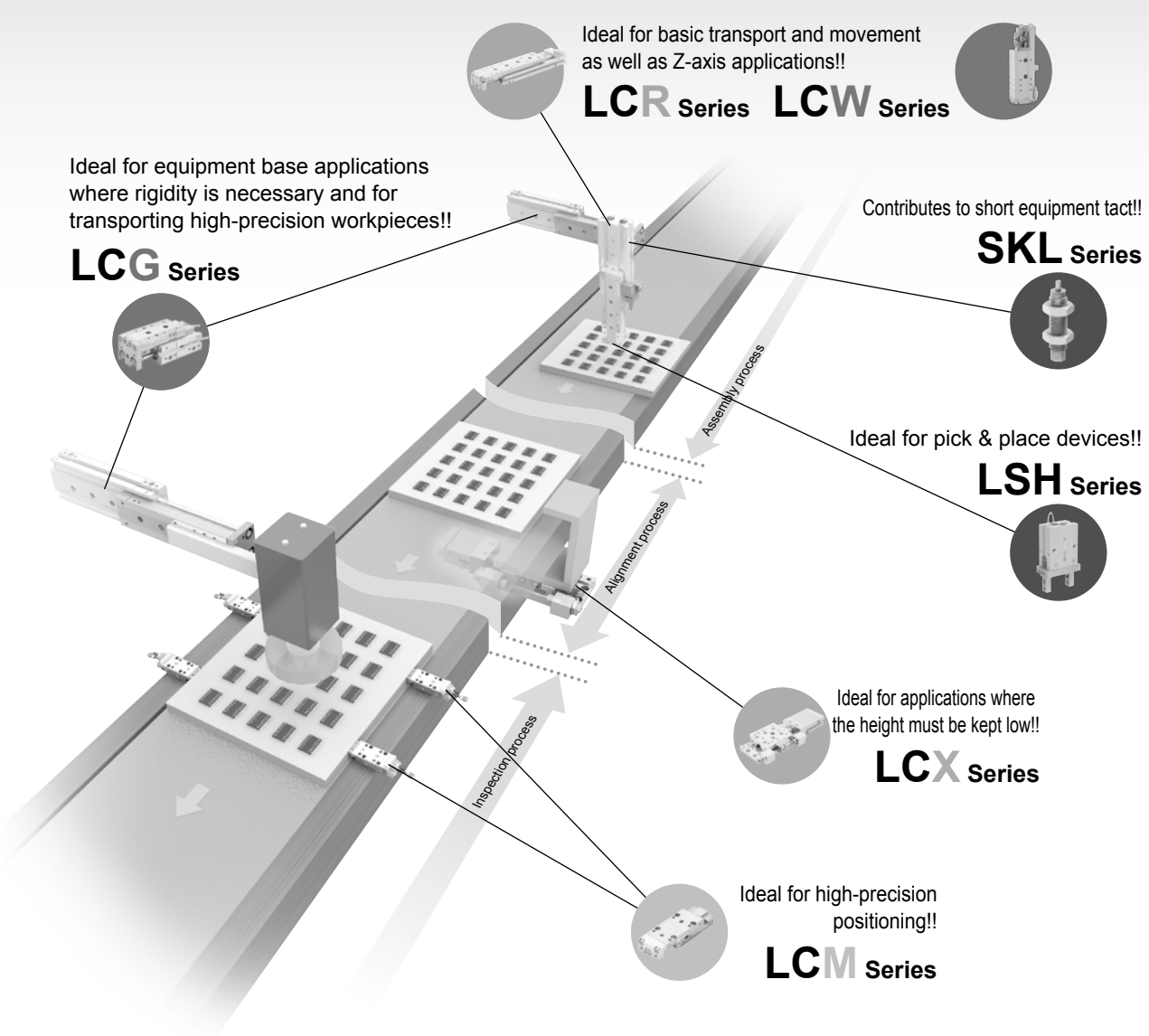

Increased flexibility in design

Increased flexibility in design is achieved, enabling symmetrical design, multi-surface piping, multi-surface mounting, mountable 2-color switch, positioning equipment and more.

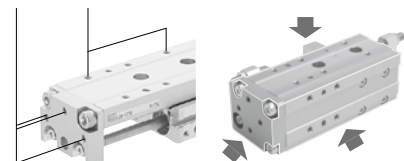
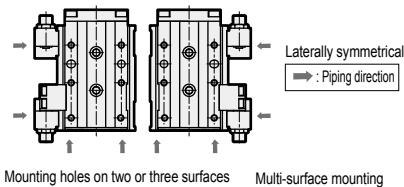

Safety mechanisms

● **Buffer mechanism**
If the driving section strikes against the workpiece when the cylinder is going forward, the buffer function is activated to protect the workpiece and cylinder. Perfect for pick & place devices.

● **Position locking mechanism**
Ensures the safety of the workpiece/cylinder during power failures or accidents.



● **Stopper mechanism**
New shock absorber SKL series adopted. Short tact and smooth stops are achieved.

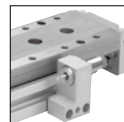
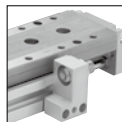

Stroke adjusting stopper

Shock absorber stopper

Environment-friendly

● **Clean-room specifications**
Models can be selected according to the cleanliness of the clean room. (Some models are excluded.)

● **Anti-rust treatment (LCG)**
The table and rail surface rustproofing reduces rust in high-humidity environments such as near ionizers.

● **P4/P40 compatible**
Rechargeable battery process compatible as materials are restricted. (except for some) (Option)

The enhanced lineup handles a variety of situations

Standard (standard specifications)

All-round model with flexible selection.

Linear slide cylinder

LCR Series

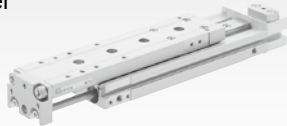

Variation		Bore size (φmm)			Stroke length (mm)				Option	
Single rod	Position locking	4.5	6	8	5	10	15	20	Stopper	Switch
Clean-room specifications	Fine speed	12	16	20	30	40	50	75	Buffer	P4
		25	32		100	125	150			

High-spec (high-precision specifications)

High-performance model with an emphasis on high precision and high rigidity.

Linear slide cylinder

LCG Series



Variation		Bore size (φmm)			Stroke length (mm)				Option	
Single rod	Position locking	4.5	6	8	5	10	15	20	Stopper	Switch
Clean-room specifications	Fine speed	12	16	20	30	40	50	75	Buffer	P4
		25	32		100	125	150			

Basic (simple specifications)

Easy to select model that combines frequently used specs.

Linear slide cylinder

LCW Series



Variation		Bore size (φmm)			Stroke length (mm)				Option	
Single rod	Position locking	4.5	6	8	5	10	15	20	Stopper	Switch
Clean-room specifications	Fine speed	12	16	20	30	40	50	75	Buffer	P4
		25	32		100	125	150			

Slim (thin/unitized specifications)

Thin model perfect for narrow spaces.

Linear slide cylinder

LCX Series

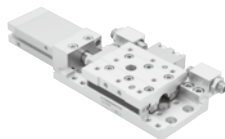

Variation		Bore size (φmm)			Stroke length (mm)				Option	
Single rod	Position locking	4.5	6	8	5	10	15	20	Stopper	Switch
Clean-room specifications	Fine speed	12	16	20	30	40	50	75	Buffer	P4
		25	32		100	125	150			

Compact (compact specifications)

Compact model that combines high precision and rigidity with a compact size.

Linear slide cylinder

LCM Series



Variation		Bore size (φmm)			Stroke length (mm)				Option	
Single rod	Position locking	4.5	6	8	5	10	15	20	Stopper	Switch
Clean-room specifications	Fine speed	12	16	20	30	40	50	75	Buffer	P4
		25	32		100	125	150			

Grips the workpiece gently and precisely.

Linear Slide Hand

LSH Series



Smooth stopping of the linear slide cylinder is achieved.

Shock absorber for linear slide cylinder

SKL Series



- LCW
- LCR
- LCG
- LCX
- LCM
- STM
- STG
- STS/STL
- STR2
- UCA2
- ULK*
- JSK/M2
- JSG
- JSC3/JSC4
- USSD
- UFCD
- USC
- JSB3
- LMB
- LML
- HCM
- HCA
- LBC
- CAC4
- UCAC2
- CAC-N
- UCAC-N
- RCC2
- RCS
- PCC
- SHC
- MCP
- GLC
- MFC
- BBS
- RRC
- GRC
- RV3*
- NHS
- HR
- LN
- Hand
- Chuk
- MecHnd/Chuk
- ShkAbs
- FJ
- FK
- SpdContr
- Ending

LCR

Linear slide cylinder

φ6/φ8/φ12/φ16/φ20/φ25

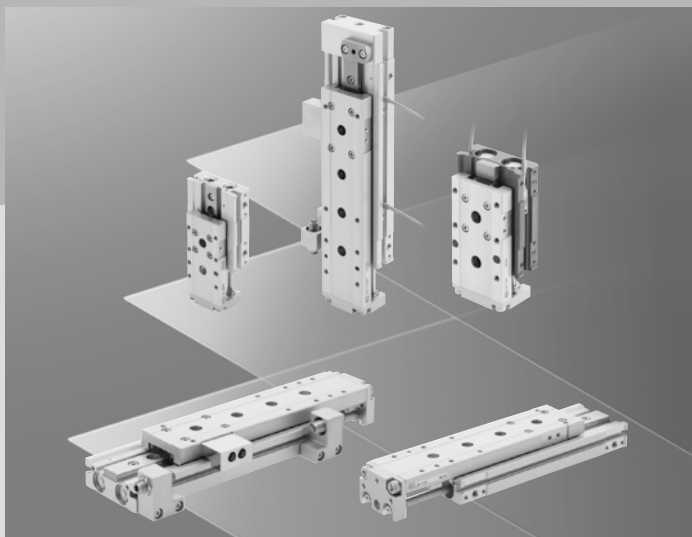

CONTENTS

Product introduction	56
Series variation	58
● Double acting/single rod (LCR)	60
● Double acting/position locking (LCR-Q)	86
● Double acting/single rod clean-room specifications (LCR-P7*)	96
● Double acting/fine speed (LCR-F)	114
● Double acting/fine speed clean-room specifications (LCR-F-P7*)	120
Selection guide	124
Technical data	129
⚠ Safety precautions	132

LCW
LCR
LCG
LCX
LCM
STM
STG
STS/STL
STR2
UCA2
ULK*
JSK/M2
JSG
JSC3/JSC4
USSD
UFCD
USC
JSB3
LMB
LML
HCM
HCA
LBC
CAC4
UCAC2
CAC-N
UCAC-N
RCC2
RCS
PCC
SHC
MCP
GLC
MFC
BBS
RRC
GRC
RV3*
NHS
HR
LN
Hand
Chuk
MecHnd/Chuk
ShkAbs
FJ
FK
SpdContr
Ending

LCR:Renewal Series

Linear slide cylinder

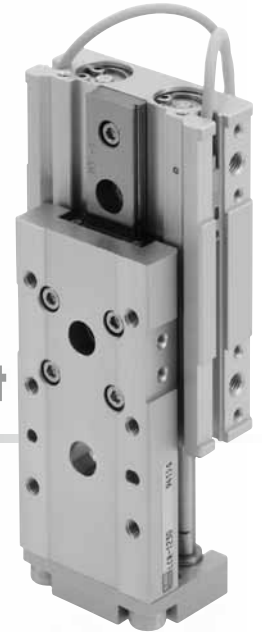

Extremely lightweight. **LCR**:Reduce Weight

Pared down to as much as 10% lighter than the conventional model.

- Compared to the conventional model: Max 10% lighter!!

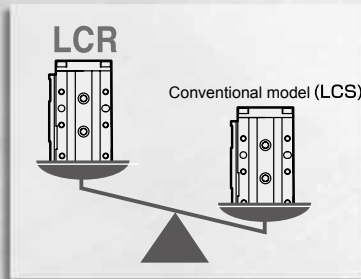

- Applications
Works perfectly on the Z-axis.

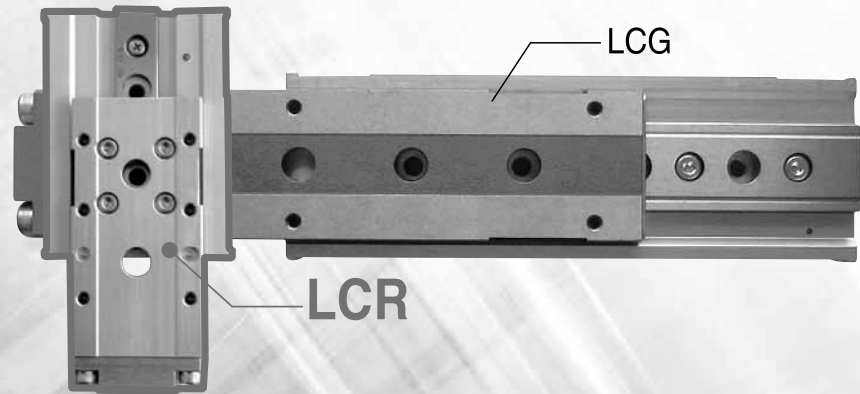

The moving part becomes lighter and thus enables efficient, energy-saving compact equipment.

Increased rigidity. **LCR** Rigidity

The highly rigid linear guide and slide table surpass the conventional model (LCS) in rigidity!

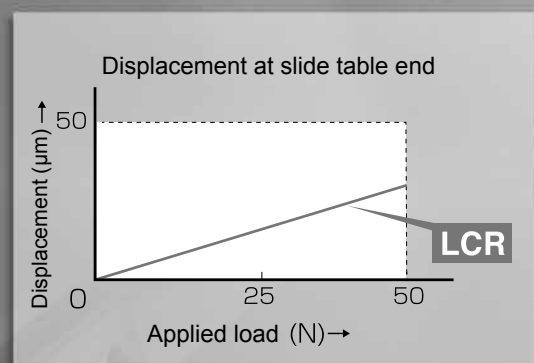
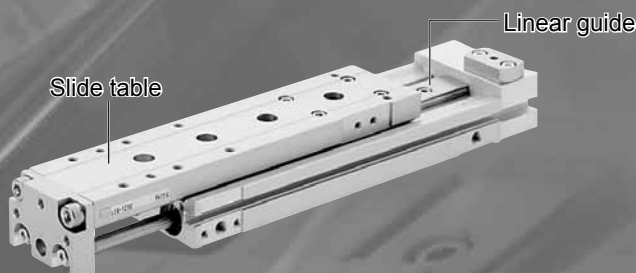

LCW
LCR
LCG
LCX
LCM
STM
STG
STS/STL
STR2
UCA2
ULK*
JSK/M2
JSG
JSC3/JSC4
USSD
UFCD
USC
JSB3
LMB
LML
HCM
HCA
LBC
CAC4
UCAC2
CAC-N
UCAC-N
RCC2
RCS
PCC
SHC
MCP
GLC
MFC
BBS
RRC
GRC
RV3*
NHS
HR
LN
Hand
Chuk
MecHnd/Chuk
ShkAbs
FJ
FK
SpdContr
Ending



Symmetrical structure Available for a variety of applications

Increased flexibility in design

Designing is more flexible with the symmetrical stoppers, multi-side piping, two-side installation and availability of a positioning hole.

Modification to the symmetrical configuration is possible
← shows the piping direction.

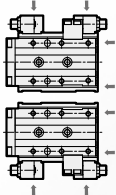

Standard rear piping port (except for φ 6)

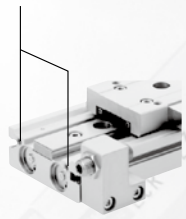

A wide variety of options and variations

The standard, position locking, clean room specifications and fine speed are available. The options include a stroke adjusting stopper, shock absorber stopper and more.

* A shock absorber stopper cannot be used with the clean room specifications.



Stroke adjusting stopper
Adjusting range on one side: 0 to 5 mm



Shock absorber stopper
Reducing impact at the stroke end.

2-color display switch

A proximity 2-color display switch is available. It does not protrude from the body and thus contributes to the simple appearance of the cylinder.

With buffer mechanism

If the driving section strikes against the workpiece when the cylinder is going forward, the buffer function is activated to protect the workpiece and cylinder. Suitable for use at the end of a pick & place device and other applications requiring a buffer function. A cylinder switch mounted to detect buffer activation enables detection of abnormality of the line (BL).

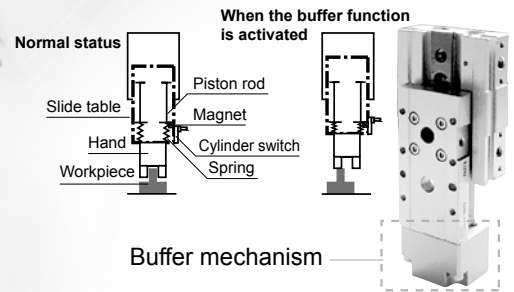

Mounting holes on two sides

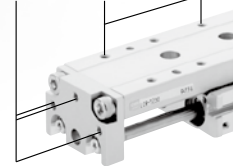

LCR product variations

Model variations	Bore size	Stroke length (mm)									Option					
		10	20	30	40	50	75	100	125	150	Stroke adjusting stopper	Shock absorber stopper	With buffer	Switch		
 Double acting/single rod LCR	φ 6															
	φ 8															
	φ 12															
	φ 16															
	φ 20/φ 25															
 Double acting/position locking LCR-Q	φ 8															
	φ 12															
	φ 16															
	φ 20/φ 25															
	 Double acting/single rod (clean room specifications) LCR-P7*	φ 6														
φ 8																
φ 12																
φ 16																
φ 20/φ 25																
 Double acting/fine speed LCR-F	φ 12															
	φ 16															
	φ 20/φ 25															
 Double acting/fine speed (clean room specifications) LCR-F-P7*	φ 12															
	φ 16															
	φ 20/φ 25															





LCW
LCR
LCG
LCX
LCM
STM
STG
STS/STL
STR2
UCA2
ULK*
JSK/M2
JSG
JSC3/JSC4
USSD
UFCD
USC
JSB3
LMB
LML
HCM
HCA
LBC
CAC4
UCAC2
CAC-N
UCAC-N
RCC2
RCS
PCC
SHC
MCP
GLC
MFC
BBS
RRC
GRC
RV3*
NHS
HR
LN
Hand
Chuk
MecHnd/Chuk
ShkAbs
FJ
FK
SpdContr
Ending

Series variation

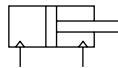
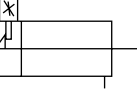

Linear slide cylinder LCR Series

LCW
LCR
 LCG
 LCX
 LCM
 STM
 STG
 STS/STL
 STR2
 UCA2
 ULK*
 JSK/M2
 JSG
 JSC3/JSC4
 USSD
 UFCD
 USC
 JSB3
 LMB
 LML
 HCM
 HCA
 LBC
 CAC4
 UCAC2
 CAC-N
 UCAC-N
 RCC2
 RCS
 PCC
 SHC
 MCP
 GLC
 MFC
 BBS
 RRC
 GRC
 RV3*
 NHS
 HR
 LN
 Hand
 Chuk
 MecHnd/Chuk
 ShkAbs
 FJ
 FK
 SpdContr
 Ending

Variation	Model No. JIS symbol	Bore size (mm)	Stroke length (mm)										
			10	20	30	40	50	75	100	125	150		
Double acting/ single rod 	LCR	φ6	●	●	●	●	●						
		φ8	●	●	●	●	●	●					
		φ12	●	●	●	●	●	●	●				
		φ16	●	●	●	●	●	●	●	●	●		
		φ20/φ25	●	●	●	●	●	●	●	●	●	●	
Double acting/ position locking 	LCR-Q	φ8	●	●	●	●	●	●					
		φ12	●	●	●	●	●	●	●				
		φ16	●	●	●	●	●	●	●	●	●		
		φ20/φ25	●	●	●	●	●	●	●	●	●	●	
Double acting/ single rod clean-room specifications 	LCR-P7*	φ6	●	●	●	●	●						
		φ8	●	●	●	●	●	●					
		φ12	●	●	●	●	●	●	●				
		φ16	●	●	●	●	●	●	●	●	●		
		φ20/φ25	●	●	●	●	●	●	●	●	●	●	
Double acting/ fine speed 	LCR-F	φ12	●	●	●	●	●	●	●				
		φ16	●	●	●	●	●	●	●	●	●		
		φ20/φ25	●	●	●	●	●	●	●	●	●	●	
Double acting/ fine speed clean-room specifications 	LCR-F-P7*	φ12	●	●	●	●	●	●	●				
		φ16	●	●	●	●	●	●	●	●	●		
		φ20/φ25	●	●	●	●	●	●	●	●	●	●	

●: Standard, ◎: Option, ○: Custom order, ■: Not available

	Option																							Switch	Page				
	Stroke adjusting stopper						Shock absorber stopper						Two-sided combined double stopper						One side hybrid stopper mix				With buffer						
	Stopper position ①	Stopper position ②	Stopper position ③	Stopper position ④	Stopper position ①/③	Stopper position ②/④	Stopper position ①	Stopper position ②	Stopper position ③	Stopper position ④	Stopper position ①/③	Stopper position ②/④	A1 + metal stopper	A2 + metal stopper	A3 + metal stopper	A4 + metal stopper	A5 + metal stopper	A6 + metal stopper	A1 + S3	A2 + S4	A3 + S1	A4 + S2	Without switch groove	With switch groove	Plug attached				
	S1	S2	S3	S4	S5	S6	A1	A2	A3	A4	A5	A6	W1	W2	W3	W4	W5	W6	C1	C2	C3	C4	B	BL	N				
	◎	◎	◎	◎	◎	◎	◎	◎	◎	◎	◎	◎	○	○	○	○	○	○	○	○	○	○	○	◎	◎	◎	◎	◎	60
	◎	◎	■	■	■	■	◎	◎	■	■	■	■	○	○	■	■	■	■	■	■	■	■	○	○	◎	◎	◎	86	
	◎	◎	◎	◎	◎	◎	■	■	■	■	■	■	■	■	■	■	■	■	■	■	■	■	■	■	■	◎	◎	96	
	◎	◎	◎	◎	◎	◎	◎	◎	◎	◎	◎	◎	○	○	○	○	○	○	○	○	○	○	○	○	◎	◎	◎	114	
	◎	◎	◎	◎	◎	◎	■	■	■	■	■	■	■	■	■	■	■	■	■	■	■	■	■	■	◎	◎	◎	120	

● Stopper position

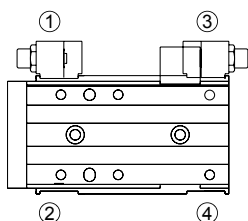

LCW
LCR
LCG
LCX
LCM
STM
STG
STS/STL
STR2
UCA2
ULK*
JSK/M2
JSG
JSC3/JSC4
USSD
UFCD
USC
JSB3
LMB
LML
HCM
HCA
LBC
CAC4
UCAC2
CAC-N
UCAC-N
RCC2
RCS
PCC
SHC
MCP
GLC
MFC
BBS
RRC
GRC
RV3*
NHS
HR
LN
Hand
Chuk
MecHnd/Chuk
ShkAbs
FJ
FK
SpdContr
Ending

LCW
LCR
 LCG
 LCX
 LCM
 STM
 STG
 STS/STL
 STR2
 UCA2
 ULK*
 JSK/M2
 JSG
 JSC3/JSC4
 USSD
 UFCD
 USC
 JSB3
 LMB
 LML
 HCM
 HCA
 LBC
 CAC4
 UCAC2
 CAC-N
 UCAC-N
 RCC2
 RCS
 PCC
 SHC
 MCP
 GLC
 MFC
 BBS
 RRC
 GRC
 RV3*
 NHS
 HR
 LN
 Hand
 Chuk
 MecHnd/Chuk
 ShkAbs
 FJ
 FK
 SpdContr
 Ending



Linear slide cylinder Double acting/single rod

LCR Series

● Bore size: $\phi 6/\phi 8/\phi 12/\phi 16/\phi 20/\phi 25$

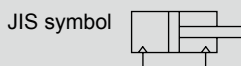

Specifications

Descriptions		LCR					
Bore size	mm	$\phi 6$	$\phi 8$	$\phi 12$	$\phi 16$	$\phi 20$	$\phi 25$
Actuation		Double acting					
Working fluid		Compressed air					
Max. working pressure	MPa	0.7 (≈ 100 psi, 7 bar)					
Min. working pressure	MPa	0.15 (≈ 22 psi, 1.5 bar) (*1)					
Proof pressure	MPa	1.05 (≈ 150 psi, 10.5 bar)					
Ambient temperature	$^{\circ}\text{C}$	-10 (14°F) to 60 (140°F) (no freezing)					
Port size	Main body side	M3	M5		Rc1/8		
	Main body back	-	M3		M5	Rc1/8	
Stroke tolerance	mm	+2.0 0 (*2)					
Working piston speed	mm/s	50 to 500 (*3)					
Cushion		With rubber cushion					
Lubrication		Not required (use turbine oil class 1 ISO VG32 if necessary for lubrication)					
Allowable absorbed energy	J	Refer to Table 3 on page 124.					

*1: 0.2 MPa when using $\phi 6$ shock absorber stopper.

*2: Note that there will be a slight gap between the end plate and floating bush if no stopper is attached.

*3: Keep within 50 to 200 mm/s when using a stroke adjusting stopper.

*4: The stroke adjusting stopper for 0.3 MPa and over working pressure is the metal sealing.

Stroke length

Bore size (mm)	Standard stroke length (mm)
$\phi 6$	10, 20, 30, 40, 50
$\phi 8$	10, 20, 30, 40, 50, 75
$\phi 12$	10, 20, 30, 40, 50, 75, 100
$\phi 16$	10, 20, 30, 40, 50, 75, 100, 125
$\phi 20$	10, 20, 30, 40, 50, 75, 100, 125, 150
$\phi 25$	10, 20, 30, 40, 50, 75, 100, 125, 150

Note: Products with stroke lengths other than the above are not available.

With buffer specifications Specifications other than the below are same as the above common specifications.

Descriptions		Content					
Bore size	mm	$\phi 6$	$\phi 8$	$\phi 12$	$\phi 16$	$\phi 20$	$\phi 25$
Buffer stroke length	mm	4		9		10	
Buffer part	Set N	3	5	10	13	17	21
spring load	Operating N	7	8	14	20	25	29

*1: In the type with buffer, adjusting the rod side stroke length will shorten the buffer stroke length and increase the spring load when set.

*2: Keep the buffer stroke length less than the stroke length above. Otherwise, malfunctions or damage may result.

Theoretical thrust table

Refer to page 125.

Switch specifications

- 1-color/2-color display

Descriptions	Reed 2-wire				Proximity 2-wire		Proximity 3-wire		
	T0H/T0V		T5H/T5V		T2H/T2V	T2WH/ T2WV	T3H/ T3V	T3PH/T3PV (custom)	T3WH/ T3WV
Applications	For programmable controller, relay		For programmable controller, relay, IC circuit (without indicator lamp), serial connection		Dedicated for programmable controller		For programmable controller, relay		
Output method	-		-		-		NPN output	PNP output	NPN output
Power supply voltage	-		-		-		10 to 28 VDC		
Load voltage	12/24 VDC	110 VAC	5/12/24 VDC	110 VAC	10 to 30 VDC	24 VDC ±10%	30 VDC or less		
Load current	5 to 50 mA	7 to 20 mA	50 mA or less	20 mA or less	5 to 20 mA		100 mA or less	50 mA or less	
Indicator lamp	LED (Lit when ON)		Without indicator lamp		LED (Lit when ON)	Red/green LED (Lit when ON)	LED (Lit when ON)	Yellow LED (Lit when ON)	Red/green LED (Lit when ON)
Leakage current	0 mA				1 mA or less		10 µA or less		
Weight	g 1 m:18 3 m:49 5 m:80								

Descriptions	Proximity 2-wire		Proximity 3-wire		Proximity 2-wire		Proximity 3-wire		
	F2S		F3S		F2H/F2V	F2YH/ F2YV	F3H/F3V	F3PH/F3PV (custom order)	F3YH/ F3YV
Applications	Dedicated for programmable controller		For programmable controller, relay		Dedicated for programmable controller		For programmable controller, relay		
Output method	-		NPN output		-		NPN output	PNP output	NPN output
Power supply voltage	-		10 to 28 VDC		-		10 to 28 VDC	4.5 to 28 VDC	10 to 28 VDC
Load voltage	10 to 30 VDC		30 VDC or less		10 to 30 VDC	24 VDC ±10%	30 VDC or less		
Load current	5 to 20 mA		50 mA or less		5 to 20 mA		100 mA or less	50 mA or less	
Indicator lamp	LED (Lit when ON)		LED (Lit when ON)		Yellow LED (Lit when ON)	Red/green LED (Lit when ON)	Yellow LED (Lit when ON)		Red/green LED (Lit when ON)
Leakage current	1 mA or less		10 µA or less		1 mA or less		10 µA or less		
Weight	g 1 m:10 3 m:29								

*1 : The T0/T5 switch can also be used with 220 VAC. Contact CKD about working conditions.

*2 : Refer to Ending Page 1 for other switch specifications.

*3 : Dimensions depend on switch model No. Refer to Ending Pages 18 and 23 for details.

Cylinder weight

- Basic

(Unit: g)

Bore size (mm)	Basic Stroke length (mm)								
	10	20	30	40	50	75	100	125	150
φ6	110	110	130	160	180	-	-	-	-
φ8	160	160	180	230	260	320	-	-	-
φ12	310	320	320	360	390	520	610	-	-
φ16	490	500	500	550	610	840	970	1,110	-
φ20	900	910	920	1,000	1,090	1,390	1,600	1,810	2,020
φ25	1,620	1,640	1,650	1,760	1,860	2,350	2,620	2,890	3,160

- Additional weight of options

(Unit: g)

Bore size (mm)	Option/stopper code				With buffer
	S1 to S4	S5/S6	A1 to A4	A5/A6	B/BL
φ6	30	40	40	50	40
φ8	40	60	50	70	40
φ12	70	100	80	110	70
φ16	110	150	120	160	80
φ20	170	250	180	270	150
φ25	290	380	300	400	320

Specifications for rechargeable battery

(Catalog No. CC-1226A)

LCR - ... -

P4*

- Design compatible with rechargeable battery manufacturing process.

* Contact CKD for details.

- LCW
- LCR
- LCG
- LCX
- LCM
- STM
- STG
- STS/STL
- STR2
- UCA2
- ULK*
- JSK/M2
- JSG
- JSC3/JSC4
- USSD
- UFCD
- USC
- JSB3
- LMB
- LML
- HCM
- HCA
- LBC
- CAC4
- UCAC2
- CAC-N
- UCAC-N
- RCC2
- RCS
- PCC
- SHC
- MCP
- GLC
- MFC
- BBS
- RRC
- GRC
- RV3*
- NHS
- HR
- LN
- Hand
- Chuk
- MecHnd/Chuk
- ShkAbs
- FJ
- FK
- SpdContr
- Ending

LCR Series

How to order

Without switch (built-in magnet for switch)

LCR - 8 - 40 - S506 DTBLN

With switch (built-in magnet for switch)

LCR - 12 - 40 - F2H* - R - S506 DTBLN

Model No.

A Bore size

B Stroke length

D Switch quantity

F Option

C Switch model No.

Precautions for model No. selection

- *1 : For the adjustable stroke range with a shock absorber stopper, refer to the stopper dimensions table on page 84.
- *2 : For the port position, refer to the stopper dimensions on page 84.
- *3 : The port positions of the standard without stopper are ① and ③ in the figure below.
- *4 : Combination of the stroke adjusting stopper and shock absorber stopper is custom order.
- *5 : Can be selected for the type with stopper only.
- *6 : A switch for buffer should be purchased separately. Refer to how to order a switch on page 66.
- *7 : Refer to the selection table on page 65 for combinations of options.
- *8 : A1**, A2**, A5** and A6** of φ6 to φ8 with 10 mm stroke length or less and φ12 to φ25 with 20 mm stroke length or less are custom order since adjustment is not possible with the standard stopper.
- *9 : When two switches are necessary for the type with S*** or A*** of φ6 to φ8 with 30 mm stroke length or less, select the F □ H type switch.
- *10 : Select when using rear piping.
- *11 : Can be selected only when using stroke adjusting stopper (S) and one side mixed type (C).
- *12 : When two switches are necessary or a switch is installed on the head side of W3 to 6 (two-sided combined stopper) of φ6 (all stroke lengths), φ8 with 20 or 30 mm stroke length, φ12 with 30 to 50 mm stroke length or φ16 with 30 to 50 mm stroke length, select the axial lead wire.
- *13 : Cannot be selected when choosing two-sided combined (W).
- *14 : The adjustable stroke range when choosing two-sided combined (W) is φ6: 9 mm, φ8: 13.5 mm, φ12: 14.5 mm, φ16: 15 mm, φ20: 13 mm, φ25: 10 mm.
- *15 : The stroke adjusting stopper for 0.3 MPa and over working pressure is the metal sealing.

[Example of model No.]

LCR-12-40-F2H-R-A1DT

Model: Linear slide cylinder double acting/single rod LCR

- A Bore size : φ12
- B Stroke length : 40 mm
- C Switch model No. : Proximity/2-wire Axial lead wire

- D Switch quantity : 1 on rod side
- E Stopper : Shock absorber stopper Stopper position ①

- F Option : With side and bottom ports Material, steel (nitriding)

E Stopper

● Stopper position

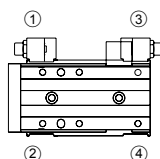

Code	Content
A Bore size	
6	φ6
8	φ8
12	φ12
16	φ16
20	φ20
25	φ25

		Bore size (φ)					
		6	8	12	16	20	25
10	10	●	●	●	●	●	●
20	20	●	●	●	●	●	●
30	30	●	●	●	●	●	●
40	40	●	●	●	●	●	●
50	50	●	●	●	●	●	●
75	75		●	●	●	●	●
100	100			●	●	●	●
125	125				●	●	●
150	150					●	●

		Voltage		Indicator lamp	Lead wire	Bore size					
Axial lead wire	Radial lead wire	AC	DC			φ6	φ8	φ12	φ16	φ20	φ25
F2S*			●	1-color display	2-wire						
F3S*			●			2-wire					
F2H*	F2V*		●				3-wire				
F3H*	F3V*		●	3-wire	●	●		●			
F3PH*	F3PV*	Proximity	●		1-color display (PNP output) (custom)	3-wire					
F2YH*	F2YV*		●	2-color display	2-wire						
F3YH*	F3YV*		●	display		3-wire					
T0H*	T0V*	Reed	●	1-color display	2-wire						
T5H*	T5V*		●	no indicator lamp		2-wire					
T2H*	T2V*		●	1-color display	2-wire						
T3H*	T3V*		●	display		3-wire					
T3PH*	T3PV*	Proximity	●	1-color display (PNP output) (custom)	3-wire					●	●
T2WH*	T2WV*		●	2-color display		2-wire					
T3WH*	T3WV*		●	display	3-wire						

* Lead wire length		Bore size (φ)					
Blank	1 m (standard)						●
3	3 m (option)						●
5	5 m (option)						●

D Switch quantity	
R	1 on rod side
H	1 on head side
D	2

E Stopper

Refer to "Stopper" on page 63.

Blank	Port on the stopper: without port
D	Port on the stopper: side and bottom ports *2, *5
Blank	Stopper block material: steel
T	Stopper block material: steel (nitriding) *5
B With buffer *6, *7	
B	Without switch groove
BL	With switch groove
Plug attached	
Blank	None
N	With side piping port plug (not available for φ6, φ25) *10

[ⓔ Stopper]

Code	Content	Code	Content
ⓔ Stopper		C One side hybrid stopper mix (shock absorber stopper, stroke adjusting stopper)	
Blank	No option	C1**	A1+S3
S Stroke adjusting stopper *4/*7		C2**	A2+S4
S1**	Stopper position ① (can be changed to ④)	C3**	A3+S1
S2**	Stopper position ② (can be changed to ③)	C4**	A4+S2
S3**	Stopper position ③ (can be changed to ②) *16	** part Adjustable stroke range ● Compatible with all. ▲ Compatible with some. *11	
S4**	Stopper position ④ (can be changed to ①) *16		
S5**	Stopper position ①, ③	Protruding end	Return end
S6**	Stopper position ②, ④	Stopper model No.	
A Shock absorber stopper *1/*4/*7		Blank	5 mm or none
A1	Stopper position ① (can be changed to ④)	02	15 mm or none
A2	Stopper position ② (can be changed to ③)	03	25 mm or none
A3	Stopper position ③ (can be changed to ②) *16	04	15 mm
A4	Stopper position ④ (can be changed to ①) *16	05	25 mm
A5	Stopper position ①, ③	06	5 mm
A6	Stopper position ②, ④	07	5 mm
W Two-sided combined double stopper (shock absorber stopper, metal stopper) *12/*14		Stopper model No.	
W1	A1 + metal stopper	S	A
W2	A2 + metal stopper	W	C
W3	A3 + metal stopper	*16: When changing the stopper position from the head side to the rod side, the stopper must be purchased separately according to the stroke length and adjustable stroke length. Refer to "Precautions when purchasing discrete stopper" on page 67. A1, A2 and adjustable stroke length of 15 mm and 25 mm may not be available depending on the stroke length.	
W4	A4 + metal stopper		
W5	A5 + metal stopper		
W6	A6 + metal stopper		

Stopper model No. selection method

1 Stopper combination table

Model No. - [ⓑ Stopper] [ⓓ Stopper position] [ⓓ] Example) LCR-8-40-[S] [5]06

Stopper position model No. [ⓓ]	Stopper model No. [ⓑ]			
	Stroke adjustable (one side)	Shock absorber (one side)	Two-sided combined double stopper	One side hybrid stopper mix
	[S]	[A]	[W]	[C]
[1]	[S1]	[A1]	[W1]	[C1]
[2]	[S2]	[A2]	[W2]	[C2]
[3]	[S3]	[A3]	[W3]	[C3]
[4]	[S4]	[A4]	[W4]	[C4]
[5]	[S5]	[A5]	[W5]	
[6]	[S6]	[A6]	[W6]	

▲ shows the piping direction.
If two-sided combined (W) is selected, the stopper bracket comes with piping on both sides, ▲ (piping direction) and the reverse side stopper bracket comes with a plug.

■ : Shock absorber stopper
■ : Stroke adjusting stopper (adjusting range 5 mm)
■ : Metal adjusting stopper (adjusting range 15 mm)

- LCW
- LCR
- LCG
- LCX
- LCM
- STM
- STG
- STS/STL
- STR2
- UCA2
- ULK*
- JSK/M2
- JSG
- JSC3/JSC4
- USSD
- UFCD
- USC
- JSB3
- LMB
- LML
- HCM
- HCA
- LBC
- CAC4
- UCAC2
- CAC-N
- UCAC-N
- RCC2
- RCS
- PCC
- SHC
- MCP
- GLC
- MFC
- BBS
- RRC
- GRC
- RV3*
- NHS
- HR
- LN
- Hand
- Chuk
- MecHnd/Chuk
- ShkAbs
- FJ
- FK
- SpdContr
- Ending

Stopper model No. selection method

2 Stopper combination table

Model No. - [①② Stopper] [③ Adjustable stroke range]

Example) LCR-8-40-S5[06]

For stroke adjusting stopper -S

- : Stroke adjusting stopper (adjusting range 5 mm)
- : Stroke adjusting stopper (adjusting range 15 mm)
- : Stroke adjusting stopper (adjusting range 25 mm)

Adjustable stroke range Model No. [③]	Stopper adjusting range		Stopper model No. [①②]					
	Protruding end	Return end	[S1]	[S2]	[S3]	[S4]	[S5]	[S6]
	Blank	5 mm or none	5 mm or none					
[02]	15 mm or none	15 mm or none						
[03]	25 mm or none	25 mm or none						
[04]	15 mm	5 mm	/					
[05]	25 mm	5 mm	/					
[06]	5 mm	15 mm	/					
[07]	5 mm	25 mm	/					

▲ shows the piping direction.
Cannot be selected for shock absorber [A] and two-sided combined [W].

3 For one side hybrid stopper mix -C

- : Shock absorber stopper
- : Stroke adjusting stopper (adjusting range 15 mm)
- : Stroke adjusting stopper (adjusting range 5 mm)
- : Stroke adjusting stopper (adjusting range 25 mm)

Adjustable stroke range Model No. [③]	Stopper adjusting range		Stopper model No. [①②]			
	Protruding end	Return end	[C1]	[C2]	[C3]	[C4]
	Blank	5 mm or shock absorber	5 mm or shock absorber			
[02]	15 mm or shock absorber	15 mm or shock absorber				
[03]	25 mm or shock absorber	25 mm or shock absorber				

▲ shows the piping direction.
For the adjustable stroke range with a shock absorber stopper, refer to the stopper dimensions table on page 84.

LCR Double acting/single rod selection table

(Combination with stroke adjusting stopper, shock absorber stopper)

●: Available —: Not available

Model No.	Stopper		Stroke adjustable																																			
	Stopper code	Stroke mm	S1						S2						S3						S4						S5						S6					
			Adjustment length code																																			
	Bore size	Stroke mm	Blank	02	03	Blank	02	03	Blank	02	03	Blank	02	03	Blank	02	03	Blank	02	03	04	05	06	07	Blank	02	03	04	05	06	07							
LCR	φ6, φ8	10	●	—	—	●	—	—	●	●	—	●	●	—	●	●	—	●	●	—	●	●	—	●	●	—	●	●	—	●	●	—						
		20 or more	●	●	—	●	●	—	●	●	—	●	●	—	●	●	—	●	●	—	●	●	—	●	●	—	●	●	—	●	●	—						
	φ12 to φ25	10	●	—	—	●	—	—	●	●	—	●	●	—	●	●	—	●	●	—	●	●	—	●	●	—	●	●	—	●	●	—						
		20 or more	●	●	—	●	●	—	●	●	—	●	●	—	●	●	—	●	●	—	●	●	—	●	●	—	●	●	—	●	●	—						
LCR-B, BL	φ6, φ8	10	●	—	—	●	—	—	●	●	—	●	●	—	●	●	—	●	●	—	●	●	—	●	●	—	●	●	—	●	●	—						
		20 or more	●	—	—	●	—	—	●	●	—	●	●	—	●	●	—	●	●	—	●	●	—	●	●	—	●	●	—	●	●	—						
	φ12 to φ25	10	●	—	—	●	—	—	●	●	—	●	●	—	●	●	—	●	●	—	●	●	—	●	●	—	●	●	—	●	●	—						
		20 or more	●	●	—	●	●	—	●	●	—	●	●	—	●	●	—	●	●	—	●	●	—	●	●	—	●	●	—	●	●	—						
LCR-B, BL	φ6, φ8	10	●	—	—	●	—	—	●	●	—	●	●	—	●	●	—	●	●	—	●	●	—	●	●	—	●	●	—	●	●	—						
		20 or more	●	—	—	●	—	—	●	●	—	●	●	—	●	●	—	●	●	—	●	●	—	●	●	—	●	●	—	●	●	—						
	φ12 to φ25	10	●	—	—	●	—	—	●	●	—	●	●	—	●	●	—	●	●	—	●	●	—	●	●	—	●	●	—	●	●	—						
		20 or more	●	●	—	●	●	—	●	●	—	●	●	—	●	●	—	●	●	—	●	●	—	●	●	—	●	●	—	●	●	—						
LCR-B, BL	φ6, φ8	10	●	—	—	●	—	—	●	●	—	●	●	—	●	●	—	●	●	—	●	●	—	●	●	—	●	●	—	●	●	—						
		20 or more	●	—	—	●	—	—	●	●	—	●	●	—	●	●	—	●	●	—	●	●	—	●	●	—	●	●	—	●	●	—						
	φ12 to φ25	10	●	—	—	●	—	—	●	●	—	●	●	—	●	●	—	●	●	—	●	●	—	●	●	—	●	●	—	●	●	—						
		20 or more	●	●	—	●	●	—	●	●	—	●	●	—	●	●	—	●	●	—	●	●	—	●	●	—	●	●	—	●	●	—						
LCR-B, BL	φ6, φ8	10	●	—	—	●	—	—	●	●	—	●	●	—	●	●	—	●	●	—	●	●	—	●	●	—	●	●	—	●	●	—						
		20 or more	●	—	—	●	—	—	●	●	—	●	●	—	●	●	—	●	●	—	●	●	—	●	●	—	●	●	—	●	●	—						
	φ12 to φ25	10	●	—	—	●	—	—	●	●	—	●	●	—	●	●	—	●	●	—	●	●	—	●	●	—	●	●	—	●	●	—						
		20 or more	●	●	—	●	●	—	●	●	—	●	●	—	●	●	—	●	●	—	●	●	—	●	●	—	●	●	—	●	●	—						
LCR-B, BL	φ6, φ8	10	●	—	—	●	—	—	●	●	—	●	●	—	●	●	—	●	●	—	●	●	—	●	●	—	●	●	—	●	●	—						
		20 or more	●	—	—	●	—	—	●	●	—	●	●	—	●	●	—	●	●	—	●	●	—	●	●	—	●	●	—	●	●	—						
	φ12 to φ25	10	●	—	—	●	—	—	●	●	—	●	●	—	●	●	—	●	●	—	●	●	—	●	●	—	●	●	—	●	●	—						
		20 or more	●	●	—	●	●	—	●	●	—	●	●	—	●	●	—	●	●	—	●	●	—	●	●	—	●	●	—	●	●	—						

Model No.	Stopper		Shock absorber						Two-sided combined double stopper						One side hybrid stopper mix															
	Stopper code	Stroke mm	A1	A2	A3	A4	A5	A6	W1	W2	W3	W4	W5	W6	C1				C2				C3				C4			
															Adjustment length code															
	Bore size	Stroke mm	Blank	02	03	Blank	02	03	Blank	02	03	Blank	02	03	Blank	02	03	Blank	02	03	Blank	02	03	Blank	02	03	Blank	02	03	
LCR	φ6, φ8	10	—	—	●	●	—	—	—	—	●	●	—	—	—	—	—	—	—	—	—	—	—	—	—	—	—	—	—	—
		20 or more	●	●	●	●	●	●	●	●	●	●	●	●	●	●	●	●	●	●	●	●	●	●	●	●	●	●	●	●
	φ12 to φ25	10	—	—	●	●	—	—	—	—	—	—	—	—	—	—	—	—	—	—	—	—	—	—	—	—	—	—	—	—
		20 or more	●	●	●	●	●	●	●	●	●	●	●	●	●	●	●	●	●	●	●	●	●	●	●	●	●	●	●	●
LCR-B, BL	φ6, φ8	10	—	—	●	●	—	—	—	—	●	●	—	—	—	—	—	—	—	—	—	—	—	—	—	—	—	—	—	—
		20 or more	●	●	●	●	●	●	●	●	●	●	●	●	●	●	●	●	●	●	●	●	●	●	●	●	●	●	●	●
	φ12 to φ25	10	—	—	●	●	—	—	—	—	—	—	—	—	—	—	—	—	—	—	—	—	—	—	—	—	—	—	—	—
		20 or more	●	●	●	●	●	●	●	●	●	●	●	●	●	●	●	●	●	●	●	●	●	●	●	●	●	●	●	●
LCR-B, BL	φ6, φ8	10	—	—	●	●	—	—	—	—	●	●	—	—	—	—	—	—	—	—	—	—	—	—	—	—	—	—	—	—
		20 or more	●	●	●	●	●	●	●	●	●	●	●	●	●	●	●	●	●	●	●	●	●	●	●	●	●	●	●	●
	φ12 to φ25	10	—	—	●	●	—	—	—	—	—	—	—	—	—	—	—	—	—	—	—	—	—	—	—	—	—	—	—	—
		20 or more	●	●	●	●	●	●	●	●	●	●	●	●	●	●	●	●	●	●	●	●	●	●	●	●	●	●	●	●

The table above also applies to combinations with option code D (with port on stopper) or T (steel stopper block (nitriding)).

LCW
LCR
LCG
LCX
LCM
STM
STG
STS/STL
STR2
UCA2
ULK*
JSK/M2
JSG
JSC3/JSC4
USSD
UFCD
USC
JSB3
LMB
LML
HCM
HCA
LBC
CAC4
UCAC2
CAC-N
UCAC-N
RCC2
RCS
PCC
SHC
MCP
GLC
MFC
BBS
RRR
GRC
RV3*
NHS
HR
LN
Hand
Chuk
MecHnd/Chuk
ShkAbs
FJ
FK
SpdContr
Ending

How to order switch

For $\phi 6$ to $\phi 12$

SW - F2H

Switch model No.
(Item © on page 62)

For $\phi 16$ to $\phi 25$

SW - T2H3

Switch model No.
(Item © on page 62)

● For buffer

SW - F 2 V 3

Output

Output	
2	DC 2-wire proximity
3	DC 3-wire proximity
Radial lead wire	
Lead wire length	
Blank	1 m (standard)
3	3 m (option)

How to order a stopper set

- Set of a stopper and stroke adjusting stopper or shock absorber stopper
- Use it when changing from the standard to the stroke adjusting stopper or shock absorber stopper.

LCR - 12 - S 2 D - S02

Bore size
(Item Ⓐ on page 62)

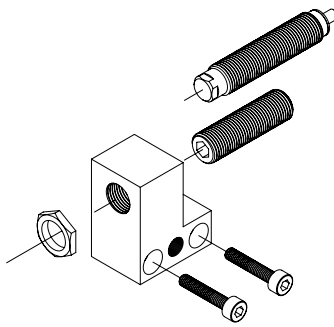

A Stopper	
S	Stroke adjusting stopper
A	Shock absorber stopper
B Stopper installation position *1	
1	Stopper position for ① or ④
2	Stopper position for ② or ③
C Port on the stopper	
Blank	Without port
D	With side and bottom ports
D Adjustable stroke length *2/*3	
Blank	Adjustable stroke range 5 mm
S02	Adjustable stroke range 15 mm
S03	Adjustable stroke range 25 mm

- *1: When installing in the stopper mounting position ① or ②, the stroke causes changes in the adjustable stroke length; see the table below.
- *2: $\phi 6$ and $\phi 8$ are not available for S03.
- *3: Cannot be selected for the shock absorber stopper "A".

Note) Bottom port is plug-sealed.
When using the bottom port with $\phi 20$ and 25 , buy a plug kit (LCR-20-N 2 pieces/set) and seal the side surface ports before using.

Precautions when purchasing the stopper set

When the stopper set is installed in the mounting position ① or ② (refer to page 62), note that the adjustable stroke length will be as shown on the right according to the stroke length.

Model No. code	Option code		Discrete stroke adjusting stopper		
			Adjustable stroke length (mm)		
	Bore size	Stroke length	-5	-15	-25
LCR Series	$\phi 6, \phi 8$	10	S02	—	—
		20 or more	Blank	S02	—
	$\phi 12$ to $\phi 25$	10	S03	—	—
		20	S02	S03	—
		30 or more	Blank	S02	S03
			Blank	S02	S03

—: Not applicable

● Stopper set weight

(Unit: g)

Stopper	S1,S2			A1,A2
Port on the stopper	Blank, D			
Adjustable stroke length	Blank	S02	S03	Blank
$\phi 6$	15	18	—	18
$\phi 8$	21	25	—	27
$\phi 12$	28	31	34	33
$\phi 16$	42	47	52	49
$\phi 20$	77	85	92	86
$\phi 25$	87	94	101	95

How to order discrete stopper bracket

- Used when changing between □ 1 (□ 3) and □ 2 (□ 4) or when changing to the stopper with port.
□ :SA

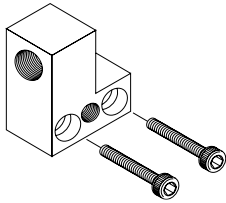

LCR - 12 - STB 1 D

Bore size
(Item ① on page 62)

A Stopper installation position	
1	For stopper position ① or ④
2	For stopper position ② or ③

B Port on the stopper	
Blank	Without port
D	With side and bottom ports

Note) Bottom port is plug-sealed.
When using the bottom port with φ20 and 25, buy a plug kit (LCR-20-N 2 pieces/set) and seal the side surface ports before using.

- Stopper bracket weight (Unit: g)

Stopper installation position	1,2
Port on the stopper	Blank, D
φ6	8
φ8	14
φ12	20
φ16	29
φ20	53
φ25	62

How to order discrete stroke adjusting stopper

- Hexagon socket set screw with urethane
- Use when changing the adjustable stroke range or when using a custom stroke length.

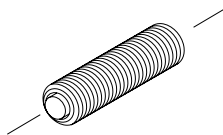

LCR - 12 - S02

Bore size
(Item ① on page 62)

A Adjustable stroke range	
S01	Single side 5 mm (standard)
S02	Single side 15 mm
S03	Single side 25 mm

Specify S01, S02 or S03 in ①.

Note: S03 is not available for φ6 and φ8.

Some models may not be available and adjustable stroke range may differ from the above depending on the model No.

Precautions when purchasing discrete stopper

When a discrete stroke adjusting stopper or a discrete shock absorber stopper is installed in the ① or ② position (refer to page 62), the combination will be as shown on the right according to the stroke length and adjustable stroke length.

Model No. code	Option code		Discrete stroke adjusting stopper			Discrete shock absorber stopper
			Adjustable stroke length (mm)			
	Bore size	Stroke length	-5	-15	-25	
LCR Series -S1, S2, S5, S6 -A1, A2, A5, A6	φ6, φ8	10	S02	—	—	—
		20 or more	S01	S02	—	A01
	φ12 to φ25	10	S03	—	—	—
		20	S02	S03	—	—
		30 or more	S01	S02	S03	A01

— : Not available

- Discrete stroke adjusting stopper weight (Unit: g)

Adjustable stroke range	S01	S02	S03
φ6	6	9	—
φ8	7	10	—
φ12	7	11	14
φ16	11	16	22
φ20	22	30	37
φ25	23	30	37

- LCW
- LCR**
- LCG
- LCX
- LCM
- STM
- STG
- STS/STL
- STR2
- UCA2
- ULK*
- JSK/M2
- JSG
- JSC3/JSC4
- USSD
- UFCD
- USC
- JSB3
- LMB
- LML
- HCM
- HCA
- LBC
- CAC4
- UCAC2
- CAC-N
- UCAC-N
- RCC2
- RCS
- PCC
- SHC
- MCP
- GLC
- MFC
- BBS
- RRC
- GRC
- RV3*
- NHS
- HR
- LN
- Hand
- Chuk
- MecHnd/Chuk
- ShkAbs
- FJ
- FK
- SpdContr
- Ending

How to order discrete shock absorber stopper

- Shock absorber set
- Use when changing from the stroke adjusting stopper or shock absorber stopper.

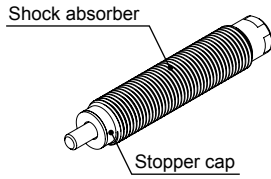

LCR - 12 - A01

Bore size
(Item A on page 62)

Note: Some models may not be available depending on the specifications. Refer to page 62. For the adjustable stroke range with a shock absorber stopper, refer to page 84.

Applicable shock absorber model No.

Model	Shock absorber model No.	Weight (g)
LCR-6	SKL-0804	9
LCR-8	SKL-0805	12
LCR-12	SKL-0805	12
LCR-16	SKL-1006	19
LCR-20	SKL-1208	31
LCR-25	SKL-1208	31

How to order discrete stopper block

- Use it when changing from the standard to the stroke adjusting stopper or shock absorber stopper.

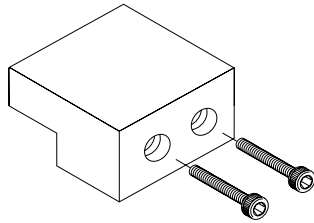

LCR - 12 - SB1 T

Bore size
(Item A on page 62)

A Stopper block	
SB1	φ6/φ8: For 30 mm stroke length or less φ12 to φ25: For 50 mm stroke length or less
SB2	φ6/φ8: For 40 mm stroke length or more φ12 to φ25: For 75 mm stroke length or more
B Material	
Blank	Stopper block material: steel
T	Stopper block material: steel (nitriding)

● Discrete stopper block weight (Unit: g)

Block	SB1(T)	SB2(T)
φ6	11	21
φ8	14	24
φ12	23	37
φ16	38	72
φ20	60	99
φ25	112	206

Model No. of plug kit for side piping port

LCR - 12 - N (2/set)

Bore size
(Item A on page 62)

● Weight of plug kit for side piping port

Bore size	Weight (g)
φ8	1
φ12	1
φ16	1
φ20	5

Internal structure and parts list

● LCR

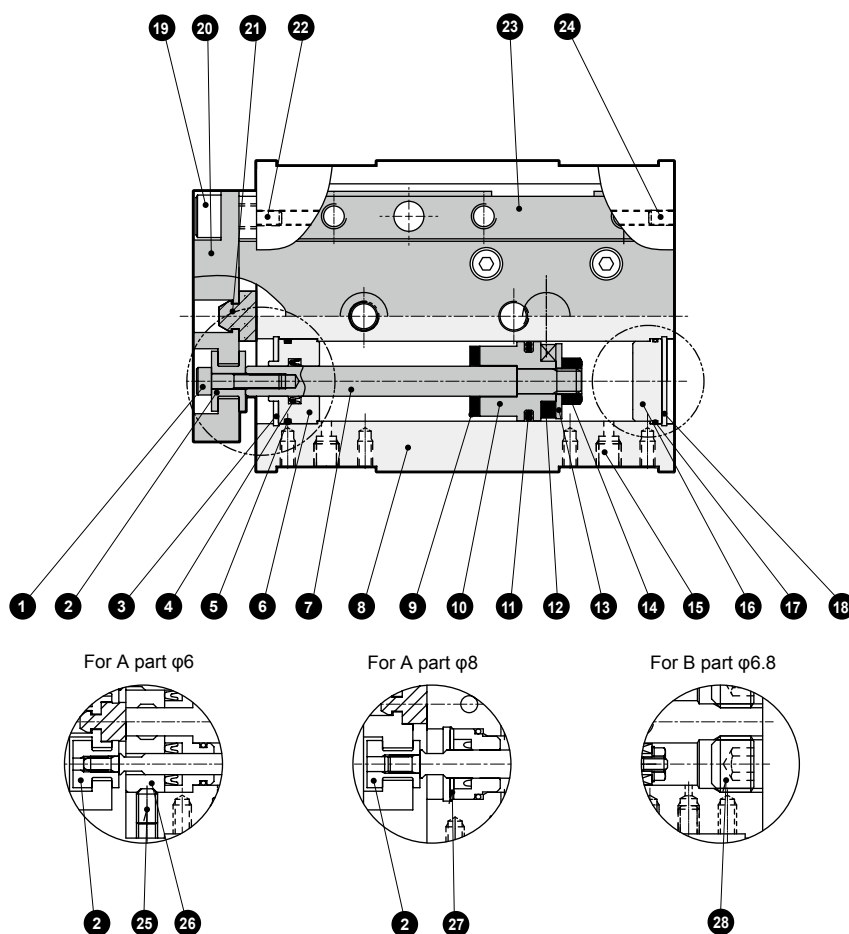

Parts list

No.	Part name	Material	Remarks	No.	Part name	Material	Remarks
1	Hexagon socket head cap screw	Alloy steel	Zinc chromate	16	Cover	Aluminum alloy	Chromate
2	Floating bush	Stainless steel		17	Cover gasket	Nitrile rubber	
3	C type snap ring	Steel	φ8 to 25 only	18	C type snap ring	Steel	φ12 to 25 only
4	Rod packing	Nitrile rubber		19	Hexagon socket head cap screw	Alloy steel	Zinc chromate
5	Metal gasket	Nitrile rubber		20	End plate	Aluminum alloy	Alumite
6	Rod metal	Aluminum alloy	Alumite	21	Cushion rubber (H)	Urethane rubber	
7	Piston rod	Stainless steel		22	Hexagon socket set screw	Stainless steel	
8	Cylinder body	Aluminum alloy	Hard alumite	23	Table	Aluminum alloy	Alumite
9	Cushion rubber (R)	Urethane rubber		24	Plug	Stainless steel	φ6 to φ20
10	Piston	Aluminum alloy	Chromate	24	Plug	Steel	φ25
11	Piston packing	Nitrile rubber		25	Hexagon socket set screw	Stainless steel	φ6 only
12	Magnet	Plastic		26	Rod metal A	Aluminum alloy	
13	Plain washer	Stainless steel		27	Cap	Stainless steel	
14	Hexagon nut	Stainless steel		28	Hexagon socket set screw	Alloy steel	Zinc chromate
15	Plug	Stainless steel	φ6 to φ16				
		Steel	φ20 to φ25				

Repair parts list

Bore size (mm)	Kit No.	Repair parts No.
φ6	LCR-6K	
φ8	LCR-8K	
φ12	LCR-12K	4 5 9
φ16	LCR-16K	11 17 21
φ20	LCR-20K	
φ25	LCR-25K	

LCW
LCR
 LCG
 LCX
 LCM
 STM
 STG
 STS/STL
 STR2
 UCA2
 ULK*
 JSK/M2
 JSG
 JSC3/JSC4
 USSD
 UFCD
 USC
 JSB3
 LMB
 LML
 HCM
 HCA
 LBC
 CAC4
 UCAC2
 CAC-N
 UCAC-N
 RCC2
 RCS
 PCC
 SHC
 MCP
 GLC
 MFC
 BBS
 RRC
 GRC
 RV3*
 NHS
 HR
 LN
 Hand
 Chuk
 MecHnd/Chuk
 ShkAbs
 FJ
 FK
 SpdContr
 Ending

Internal structure and parts list

Structure with stopper

● Type with port on stopper side and bottom (code D)

● Without port on the stopper

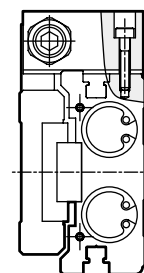
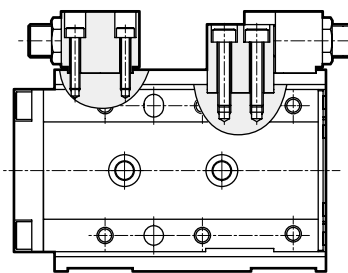
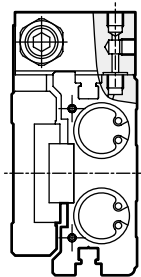
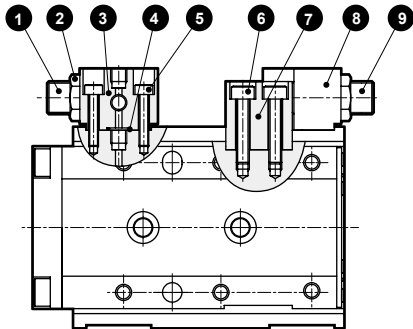
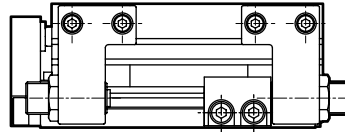
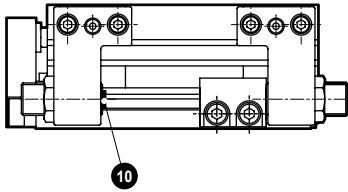

Parts list

No.	Part name	Material	Remarks	No.	Part name	Material	Remarks
1	Stopper bolt	Alloy steel	Nickeling	7	Stopper block (Stopper block code: Blank)	Steel	Nickeling
2	Hexagon nut	Alloy steel	Nickeling		Stopper block (Stopper block code: T)	Steel	Nitriding
3	Stopper A	Aluminum alloy	Alumite	8	Stopper B	Aluminum alloy	Alumite
4	Gasket	Urethane rubber		9	Stopper bolt	Alloy steel	Nickeling
5	Hexagon socket head cap screw	Alloy steel	Zinc chromate	10	Cushion rubber	Urethane rubber	
6	Hexagon socket head cap screw	Alloy steel	Zinc chromate				

Structure diagram with buffer

LCR-**-B*

● With buffer, without switch groove

● With buffer, with switch groove

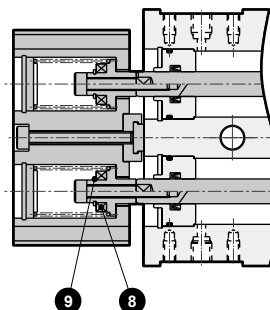
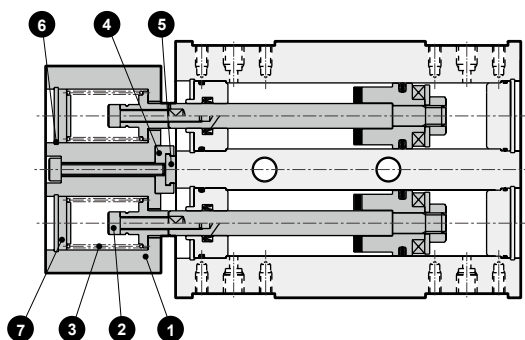

Parts list

No.	Part name	Material	Remarks	No.	Part name	Material	Remarks
1	End plate	Aluminum alloy	Alumite	6	C type snap ring	Steel	
2	Hexagon socket head cap screw	Alloy steel	Zinc chromate	7	Cover	Aluminum alloy	Chromate
3	Coil spring	Steel		8	Magnet	Plastic	
4	Stopper	φ6: Stainless steel φ8 to 25: Aluminum alloy		9	E-ring	φ6 to 12: Stainless steel φ16 to 25: Steel	
5	Cushion rubber	Urethane rubber					

LCW
LCR
LCG
LCX
LCM
STM
STG
STS/STL
STR2
UCA2
ULK*
JSK/M2
JSG
JSC3/JSC4
USSD
UFCD
USC
JSB3
LMB
LML
HCM
HCA
LBC
CAC4
UCAC2
CAC-N
UCAC-N
RCC2
RCS
PCC
SHC
MCP
GLC
MFC
BBS
RRC
GRC
RV3*
NHS
HR
LN
Hand
Chuk
MecHnd/Chuk
ShkAbs
FJ
FK
SpdContr
Ending



Dimensions (bore size: $\phi 6$)

- LCR-6
Stroke length: 10, 20, 30
(Body mounting hole in the figure shows 20 mm stroke length)

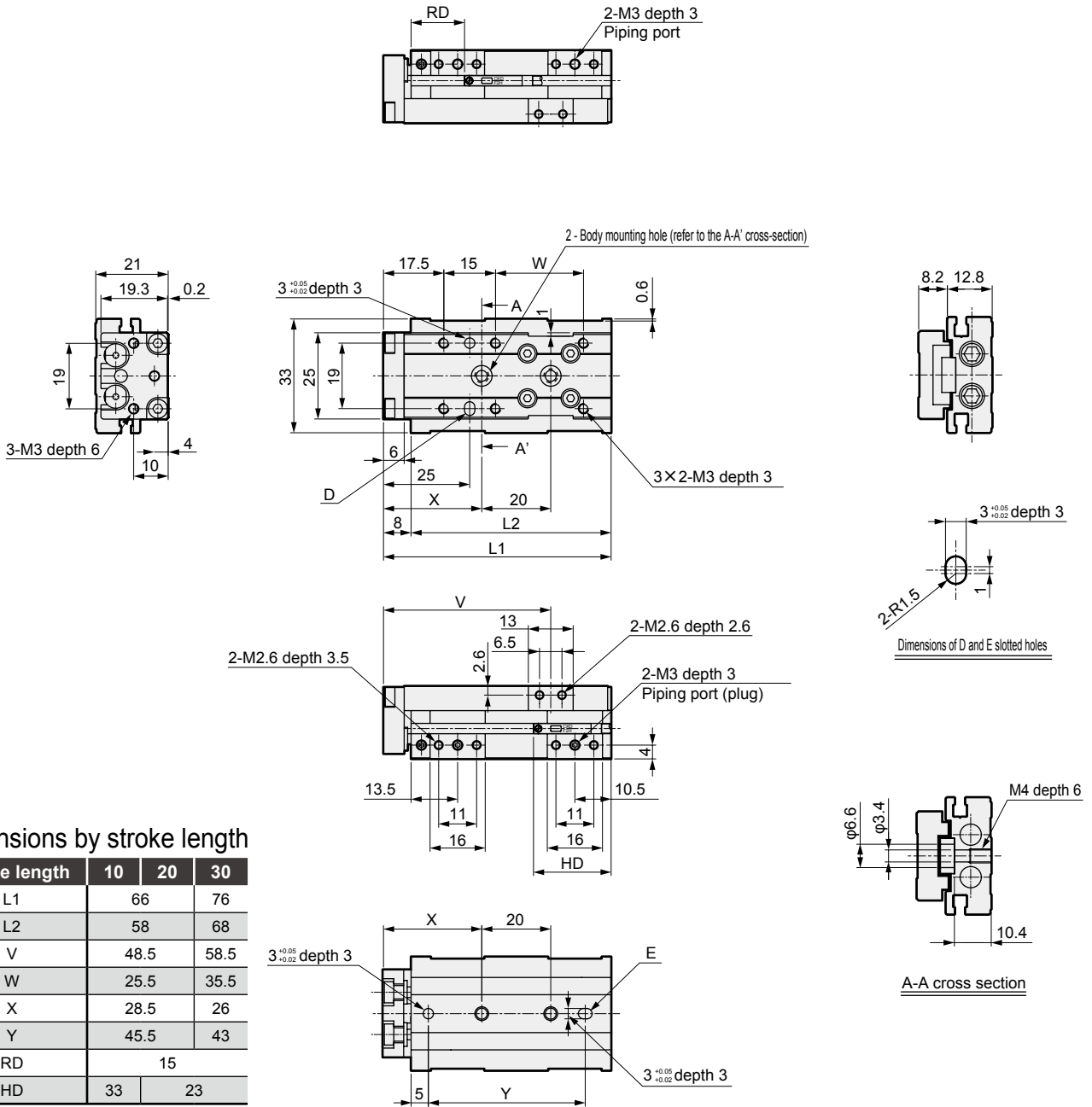

Dimensions by stroke length

Stroke length	10	20	30
L1	66	76	
L2	58	68	
V	48.5	58.5	
W	25.5	35.5	
X	28.5	26	
Y	45.5	43	
RD		15	
HD	33	23	

- Dimensions of protruding section when the F2S or F3S cylinder switch is mounted

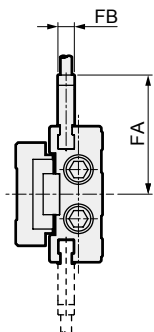

Stroke length	10	20	30
FA		29.1	
FB		4	
RD		14	
HD	34	24	

*1: When using a positioning hole, use a pin of dimensions that do not require press fitting. The recommended tolerance of a pin is JIS tolerance m6 or less.

Dimensions (bore size: $\phi 6$)



● LCR-6

Stroke length: 40, 50

(Body mounting hole in the figure shows 50 mm stroke length)

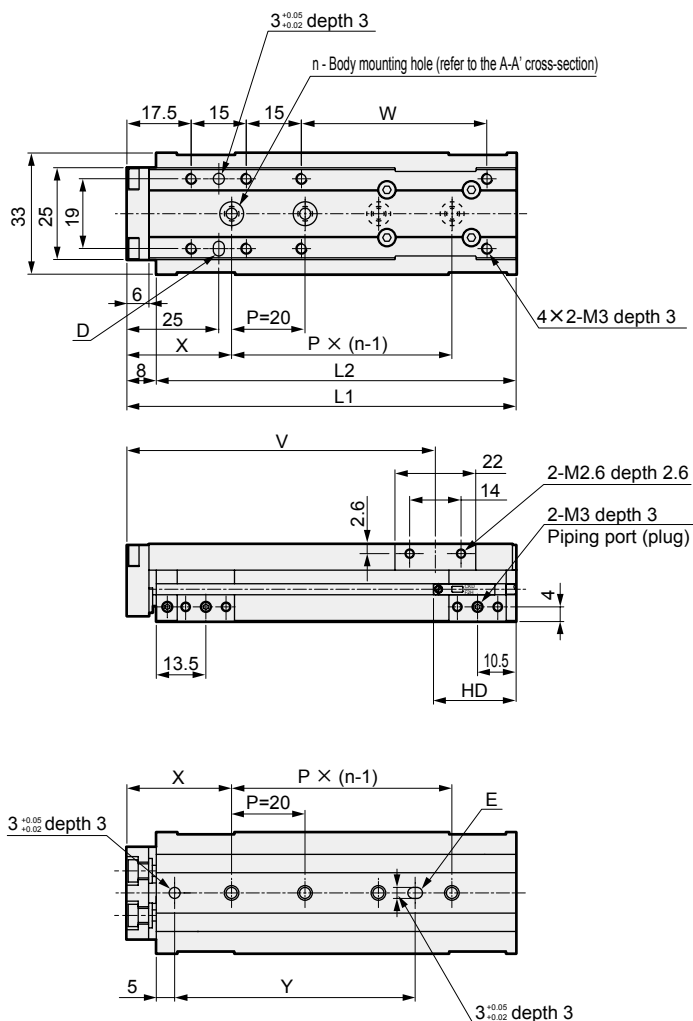

Dimensions by stroke length

Stroke length	40	50
L1	96	106
L2	88	98
n	3	4
V	74	84
W	40.5	50.5
X	27	28.5
Y	44	65.5
RD	15	
HD	33	

● Dimensions of protruding section when the F2S or F3S cylinder switch is mounted

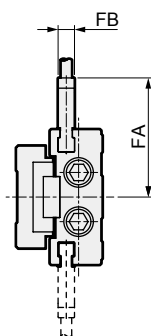

Stroke length	40	50
FA	29.1	
FB	4	
RD	14	
HD	34	

*1: When using a positioning hole, use a pin of dimensions that do not require press fitting.
The recommended tolerance of a pin is JIS tolerance m6 or less.

LCW
LCR
LCG
LCX
LCM
STM
STG
STS/STL
STR2
UCA2
ULK*
JSK/M2
JSG
JSC3/JSC4
USSD
UFCD
USC
JSB3
LMB
LML
HCM
HCA
LBC
CAC4
AC2
CAC-N
UCAC-N
RCC2
RCS
PCC
SHC
MCP
GLC
MFC
BBS
RRC
GRC
RV3*
NHS
HR
LN
Hand
Chuk
MecHnd/Chuk
ShkAbs
FJ
FK
SpdContr
Ending

Dimensions (bore size: $\phi 8$)



● LCR-8

Stroke length: 10, 20, 30
(Body mounting hole in the figure shows 30 mm stroke length)

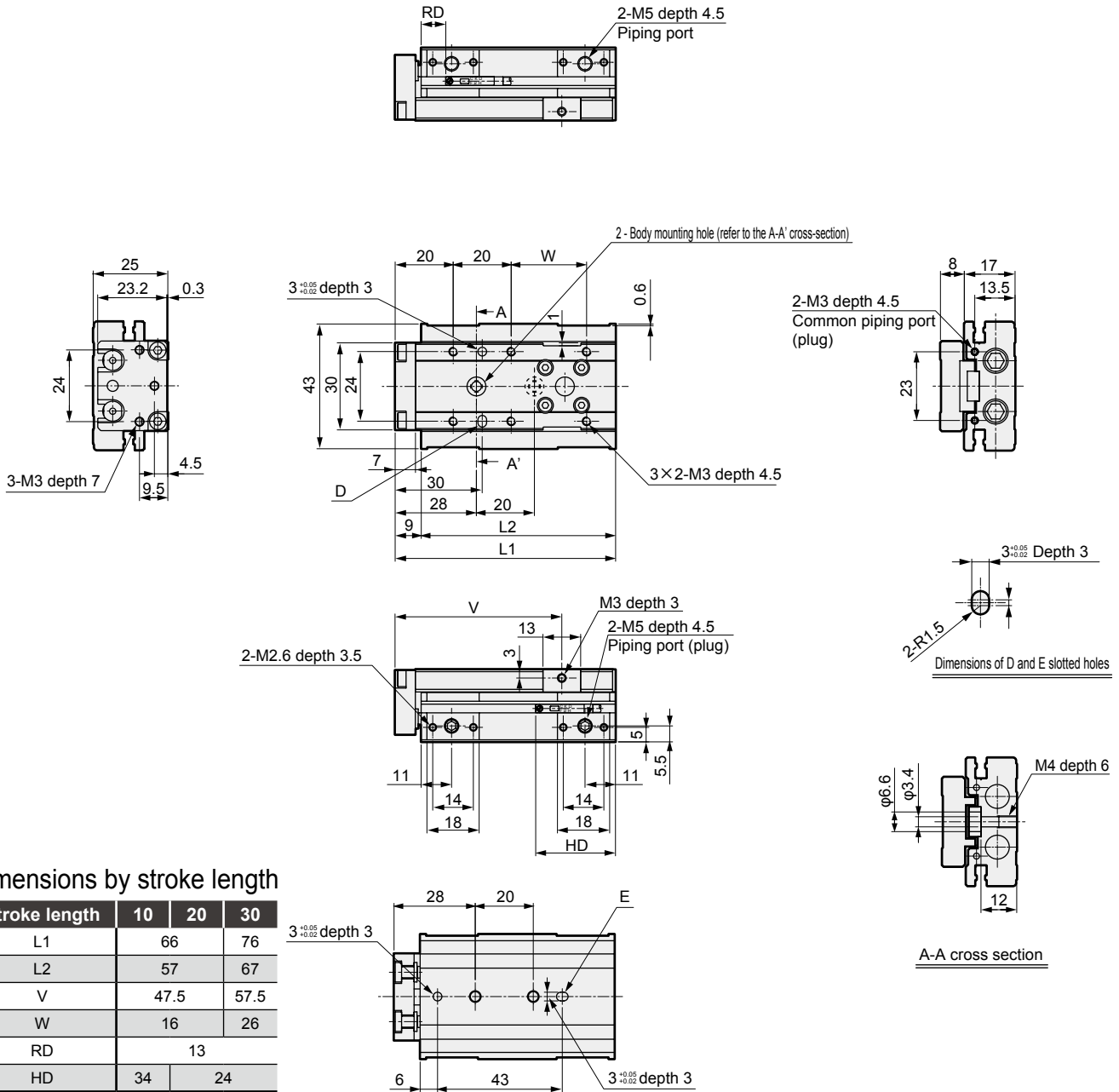

Dimensions by stroke length

Stroke length	10	20	30
L1	66	76	
L2	57	67	
V	47.5	57.5	
W	16	26	
RD	13		
HD	34	24	

● Dimensions of protruding section when the F2S or F3S cylinder switch is mounted

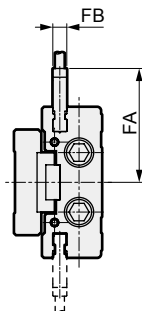

Stroke length	10	20	30
FA	32.6		
FB	4		
RD	12		
HD	35	25	

*1 : When using a positioning hole, use a pin of dimensions that do not require press fitting. The recommended tolerance of a pin is JIS tolerance m6 or less.

*2 : When using rear piping, refer to the cautions of

1. Common; when piping on page 133.

Dimensions (bore size: $\phi 8$)



● LCR-8

Stroke length: 40, 50, 75

(Body mounting hole in the figure shows 50 mm stroke length)

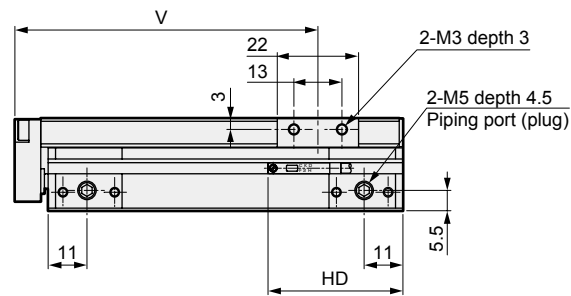
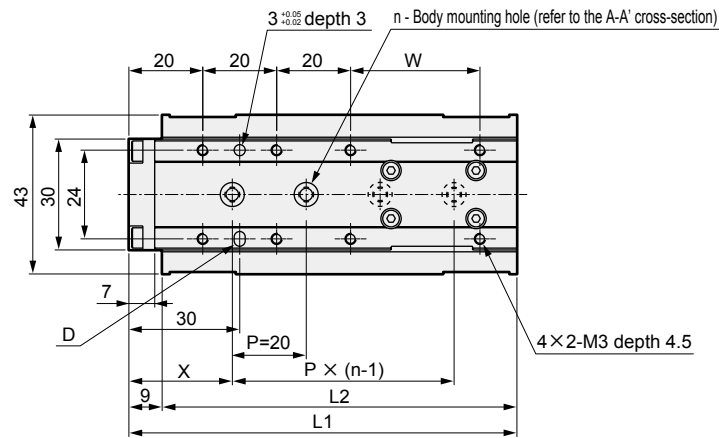

Dimensions by stroke length

Stroke length	40	50	75
L1	95	105	130
L2	86	96	121
n	3	4	5
V	72	82	107
W	25	35	60
X	26.5	28	25
Y	41.5	63	80
RD	13		
HD	33		

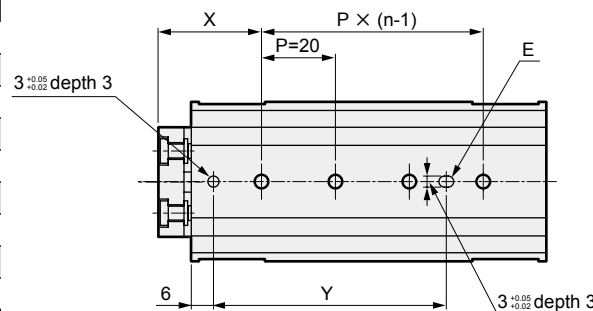

● Dimensions of protruding section when the F2S or F3S cylinder switch is mounted

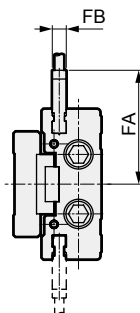

Stroke length	40	50	75
FA	32.6		
FB	4		
RD	12		
HD	34		

*1 : When using a positioning hole, use a pin of dimensions that do not require press fitting.
The recommended tolerance of a pin is JIS tolerance m6 or less.

*2 : When using rear piping, refer to the cautions of [1. Common; when piping](#) on page 133.

LCW
LCR
LCG
LCX
LCM
STM
STG
STS/STL
STR2
UCA2
ULK*
JSK/M2
JSG
JSC3/JSC4
USSD
UFCD
USC
JSB3
LMB
LML
HCM
HCA
LBC
CAC4
UCAC2
CAC-N
UCAC-N
RCC2
RCS
PCC
SHC
MCP
GLC
MFC
BBS
RRC
GRC
RV3*
NHS
HR
LN
Hand
Chuk
MecHnd/Chuk
ShkAbs
FJ
FK
SpdContr
Ending

Dimensions (bore size: $\phi 12$)



● LCR-12

Stroke: 10, 20, 30, 40, 50

(Body mounting hole in the figure shows 30 mm stroke length)

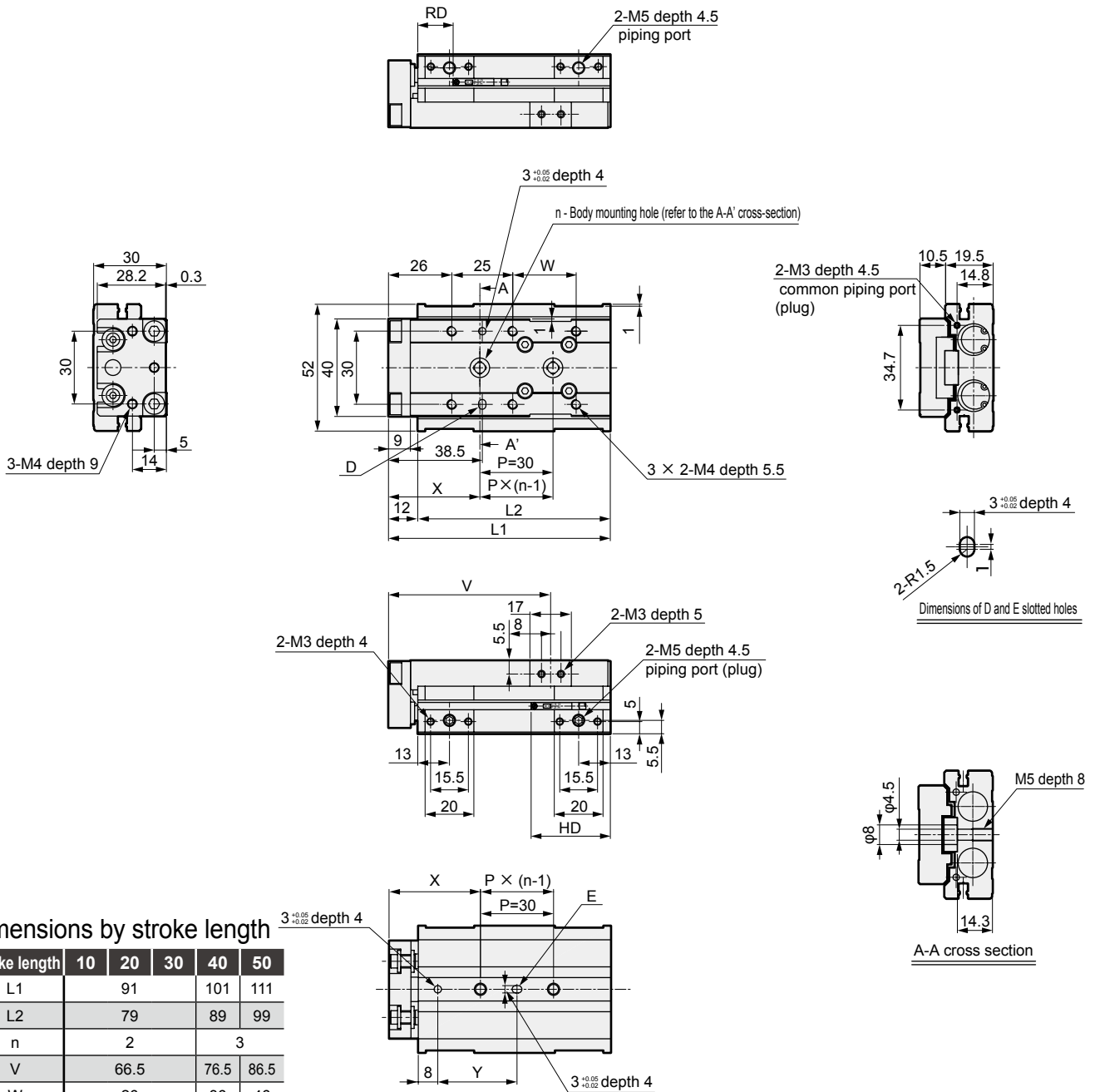

Dimensions by stroke length

Stroke length	10	20	30	40	50
L1		91	101	111	
L2		79	89	99	
n		2		3	
V		66.5	76.5	86.5	
W		26	36	46	
X		37.5	36	32	
Y		32.5	31	57	
RD		16.5			
HD	52.5	42.5		32.5	

● Dimensions of protruding section when the F2S or F3S cylinder switch is mounted

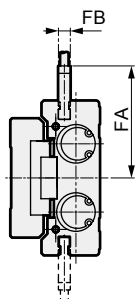

Stroke length	10	20	30	40	50
FA			37.8		
FB			4		
RD			15.5		
HD	53.5	43.5		33.5	

- *1 : When using a positioning hole, use a pin of dimensions that do not require press fitting. The recommended tolerance of a pin is JIS tolerance m6 or less.
- *2 : When using rear piping, refer to the cautions of 1. Common; when piping on page 133.

Dimensions (bore size: $\phi 12$)



● LCR-12

Stroke length: 75, 100

(Body mounting hole in the figure shows 75 mm stroke length)

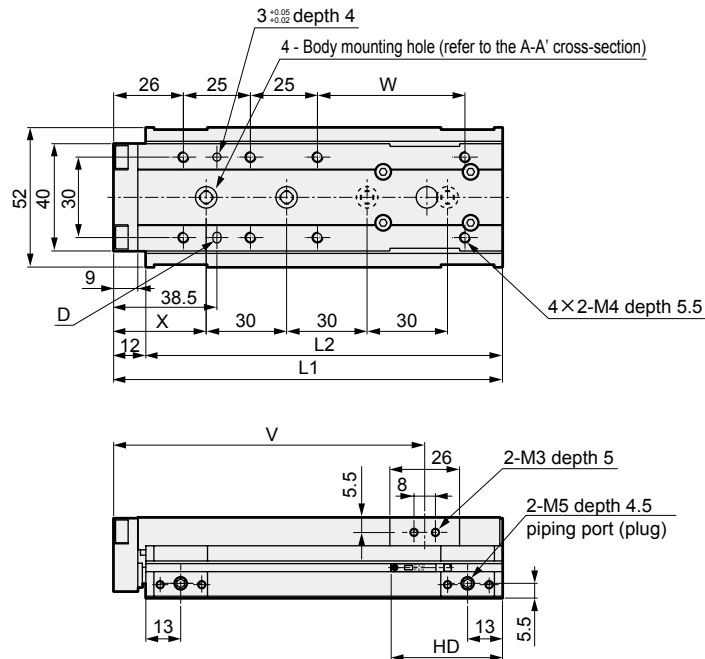

Dimensions by stroke length

Stroke length	75	100
L1	145	170
L2	133	158
V	116	141
W	55	80
X	34.5	47
Y	89.5	102
RD	16.5	
HD	41.5	

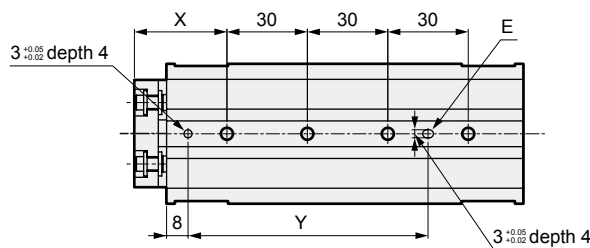

● Dimensions of protruding section when the F2S or F3S cylinder switch is mounted

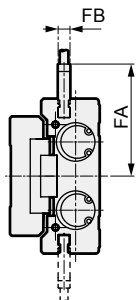

Stroke length	75	100
FA	37.8	
FB	4	
RD	15.5	
HD	42.5	

*1 : When using a positioning hole, use a pin of dimensions that do not require press fitting. The recommended tolerance of a pin is JIS tolerance m6 or less.

*2 : When using rear piping, refer to the cautions of

1. Common; when piping on page 133.

LCW
LCR
LCG
LCX
LCM
STM
STG
STS/STL
STR2
UCA2
ULK*
JSK/M2
JSG
JSC3/JSC4
USSD
UFCD
USC
JSB3
LMB
LML
HCM
HCA
LBC
CAC4
UCAC2
CAC-N
UCAC-N
RCC2
RCS
PCC
SHC
MCP
GLC
MFC
BBS
RRC
GRC
RV3*
NHS
HR
LN
Hand
Chuk
MecHnd/Chuk
ShkAbs
FJ
FK
SpdContr
Ending

Dimensions (bore size: $\phi 16$)



● LCR-16

Stroke length: 75, 100, 125

(Body mounting hole in the figure shows 75 mm stroke length)

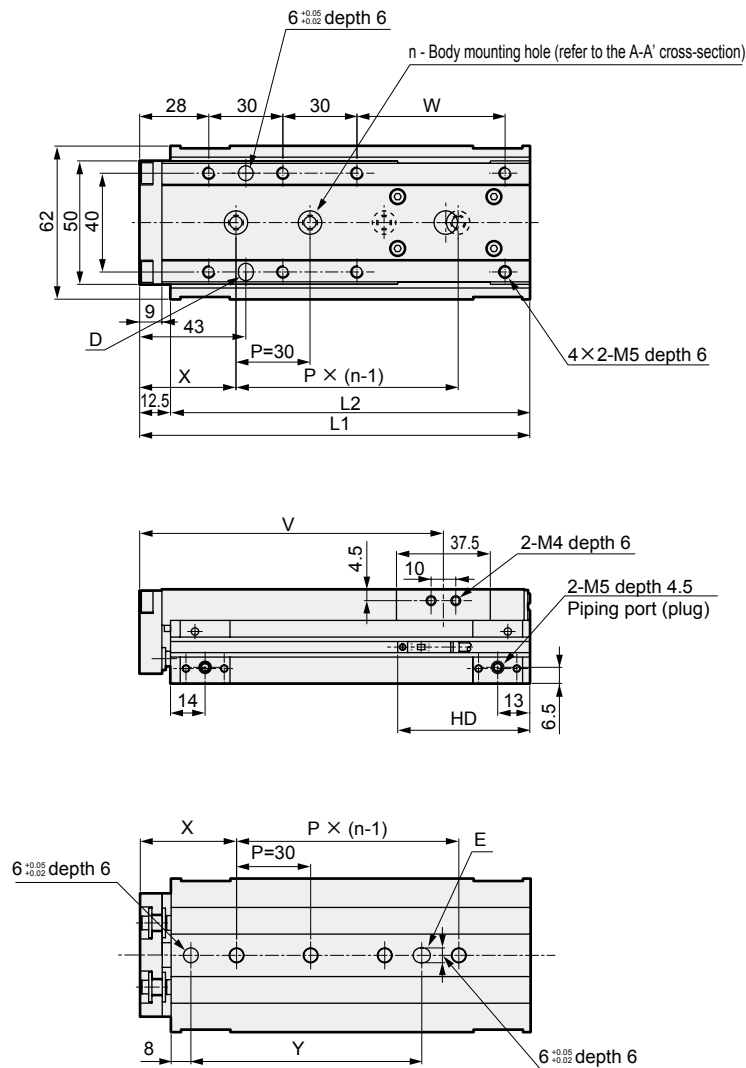

Dimensions by stroke length

Stroke length	75	100	125
L1	158	183	208
L2	145.5	170.5	195.5
n	4	5	
V	123.3	148.3	173.3
W	60	85	110
X	39	37	49
Y	93.5	121.5	133.5
T0/5*	RD	17	
	HD	53.5	
T2/3*	RD	19.5	
	HD	51	

*1 : When using a positioning hole, use a pin of dimensions that do not require press fitting.

The recommended tolerance of a pin is JIS tolerance m6 or less.

*2 : When using rear piping, refer to the cautions of

1. Common; when piping on page 133.

LCW
LCR
LCG
LCX
LCM
STM
STG
STS/STL
STR2
UCA2
ULK*
JSK/M2
JSG
JSC3/JSC4
USSD
UFCD
USC
JSB3
LMB
LML
HCM
HCA
LBC
CAC4
UCAC2
CAC-N
UCAC-N
RCC2
RCS
PCC
SHC
MCP
GLC
MFC
BBS
RRC
GRC
RV3*
NHS
HR
LN
Hand
Chuk
MecHnd/Chuk
ShkAbs
FJ
FK
SpdContr
Ending

Dimensions (bore size: $\phi 20$)



● LCR-20

Stroke: 10, 20, 30, 40, 50

(Body mounting hole in the figure shows 30 mm stroke length)

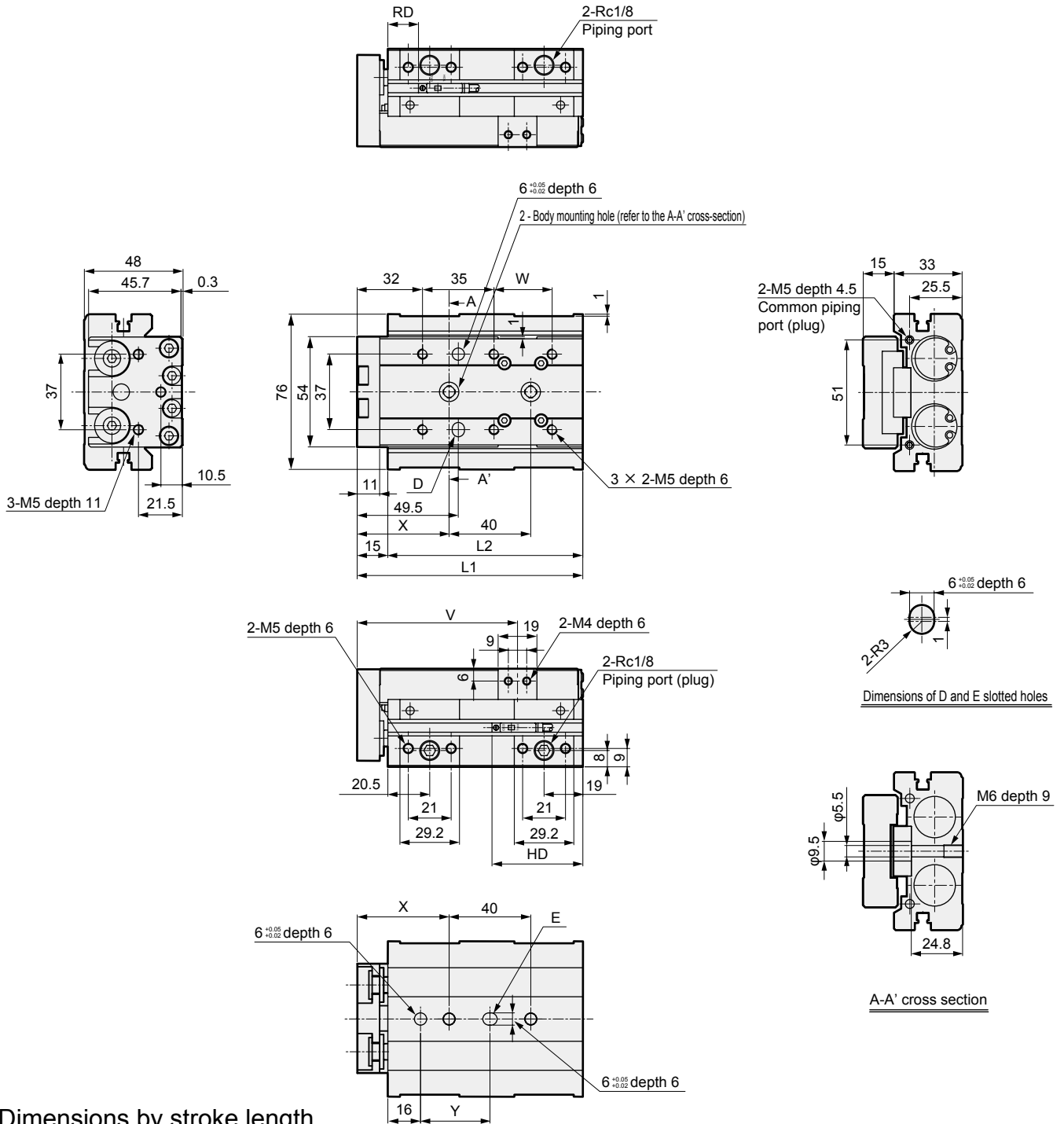

Dimensions by stroke length

Stroke length	10	20	30	40	50
L1		110.5	120.5	130.5	
L2		95.5	105.5	115.5	
V		78.5	88.5	98.5	
W		28.5	38.5	48.5	
X		45	51	49	
Y		34	40	38	
T0/5*	RD	20.5			
T2/3*	HD	65	55	45	
T2/3W*	RD	22			
	HD	63	53	43	

*1 : When using a positioning hole, use a pin of dimensions that do not require press fitting. The recommended tolerance of a pin is JIS tolerance m6 or less.

*2 : When using rear piping, refer to the cautions of

1. Common; when piping on page 133.

Dimensions (bore size: $\phi 20$)



● LCR-20

Stroke length: 75, 100, 125, 150

(Body mounting hole in the figure shows 100 mm stroke length)

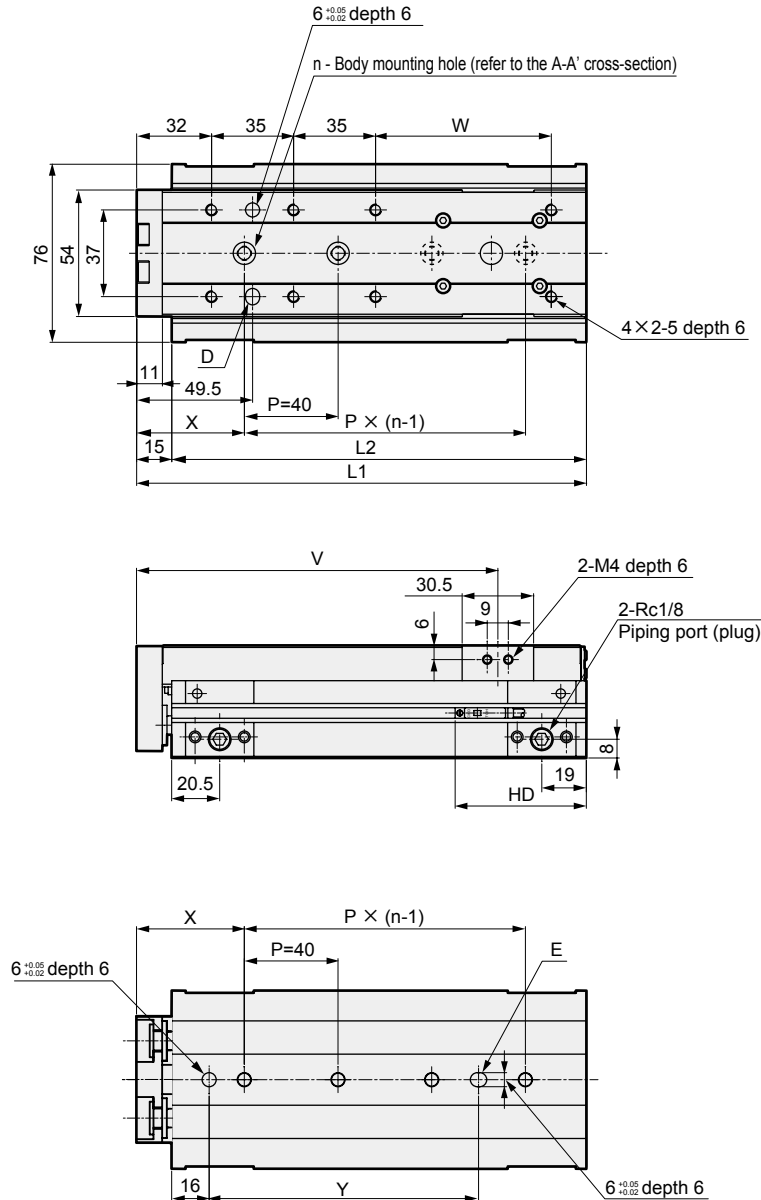

Dimensions by stroke length

Stroke length	75	100	125	150
L1	167	192	217	242
L2	152	177	202	227
n	3	4	5	
V	129.3	154.3	179.3	204.3
W	50	75	100	125
X	46	53	51	
Y	75	115	122	160
T0/5*	RD	20.5		
T2/3*	HD	57.5		
T2/3W*	RD	22		
	HD	55.5		

*1 : When using a positioning hole, use a pin of dimensions that do not require press fitting.
The recommended tolerance of a pin is JIS tolerance m6 or less.

*2 : When using rear piping, refer to the cautions of 1. Common; when piping on page 133.

LCW
LCR
LCG
LCX
LCM
STM
STG
STS/STL
STR2
UCA2
ULK*
JSK/M2
JSG
JSC3/JSC4
USSD
UFCD
USC
JSB3
LMB
LML
HCM
HCA
LBC
CAC4
UCAC2
CAC-N
UCAC-N
RCC2
RCS
PCC
SHC
MCP
GLC
MFC
BBS
RRC
GRC
RV3*
NHS
HR
LN
Hand
Chuk
MecHnd/Chuk
ShkAbs
FJ
FK
SpdContr
Ending



Dimensions (bore size: $\phi 25$)

● LCR-25

Stroke: 10, 20, 30, 40, 50

(Body mounting hole in the figure shows 30 mm stroke length)

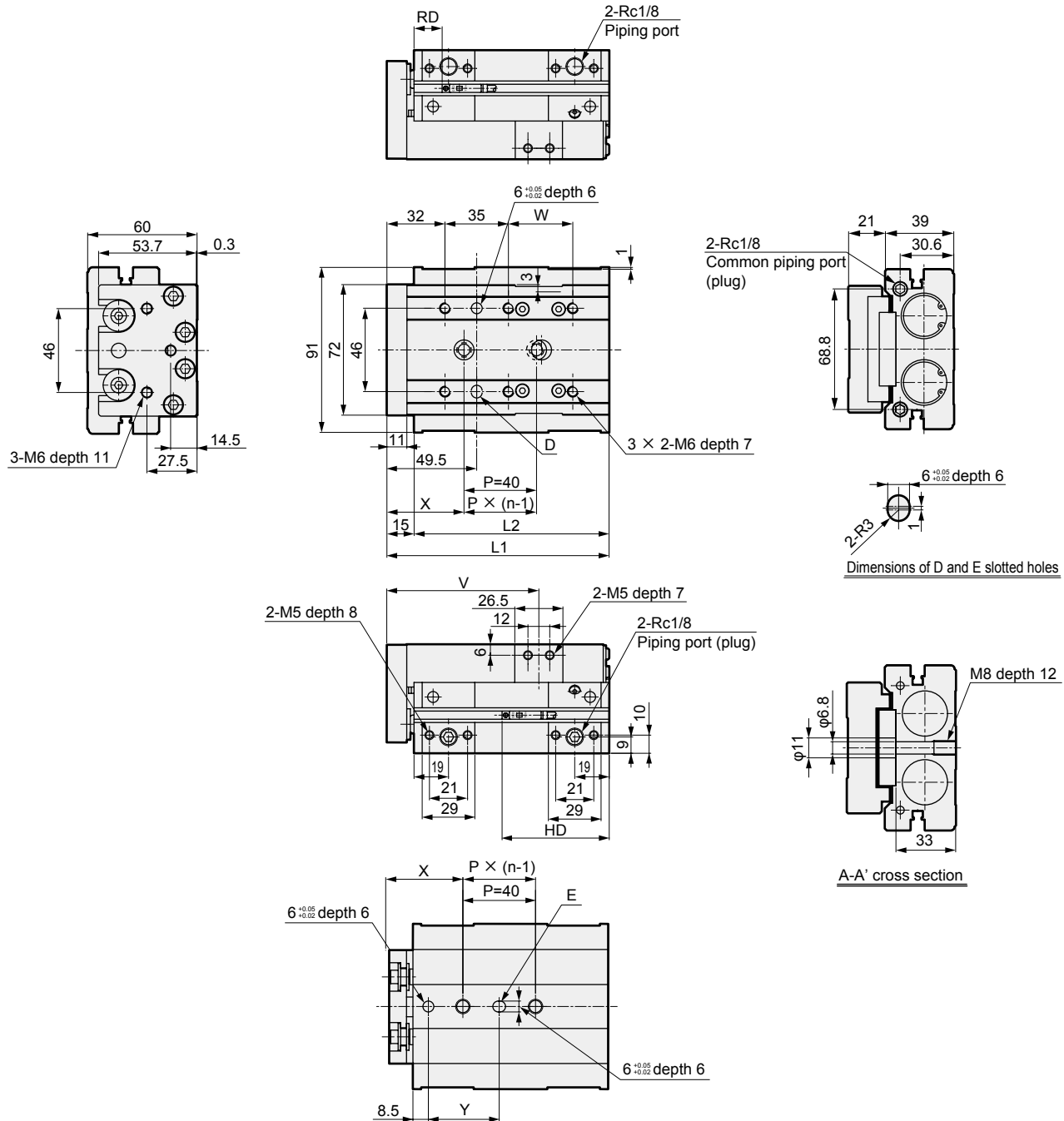

Dimensions by stroke length

Stroke length	10	20	30	40	50
L1		122.5	132.5	142.5	
L2		107.5	117.5	127.5	
n		2	3	2	
V		83.8	93.8	103.8	
W		35.5	45.5	55.5	
X		42.5	45.5	60.5	
Y		39	42	57	
T0/5*	RD	19			
T2/3*	HD	78.5	68.5	58.5	
T2/3W*	RD	21			
	HD	76.5	66.5	56.5	

*1 : When using a positioning hole, use a pin of dimensions that do not require press fitting.
The recommended tolerance of a pin is JIS tolerance m6 or less.

*2 : When using rear piping, refer to the cautions of

1. Common; when piping on page 133.

Dimensions (bore size: φ25)



● LCR-25

Stroke length: 75, 100, 125, 150

(Body mounting hole in the figure shows 100 mm stroke length)

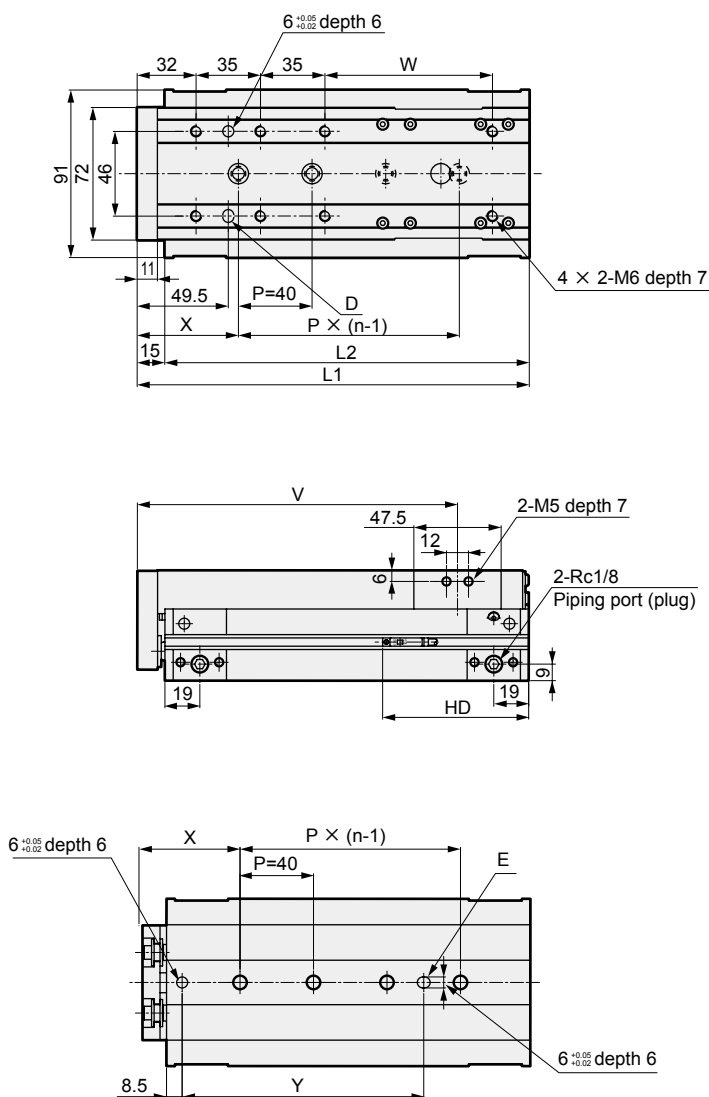

Dimensions by stroke length

Stroke length	75	100	125	150
L1	188	213	238	263
L2	173	198	223	248
n	3	4	5	
V	138.8	163.8	188.8	213.8
W	66	91	116	141
X	60	55	45	60
Y	96.5	131.5	161.5	176.5
T0/5*	RD	19		
	HD	79		
T2/3*	RD	21		
	HD	77		

*1 : When using a positioning hole, use a pin of dimensions that do not require press fitting.

The recommended tolerance of a pin is JIS tolerance m6 or less.

*2 : When using rear piping,

refer to the cautions of

1. Common; when piping on page 133.

LCW
LCR
LCG
LCX
LCM
STM
STG
STS/STL
STR2
UCA2
ULK*
JSK/M2
JSG
JSC3/JSC4
USSD
UFCD
USC
JSB3
LMB
LML
HCM
HCA
LBC
CAC4
UCAC2
CAC-N
UCAC-N
RCC2
RCS
PCC
SHC
MCP
GLC
MFC
BBS
RRC
GRC
RV3*
NHS
HR
LN
Hand
Chuk
MecHnd/Chuk
ShkAbs
FJ
FK
SpdContr
Ending

Dimensions: Option

● Stroke adjusting stopper (S1 to S6)

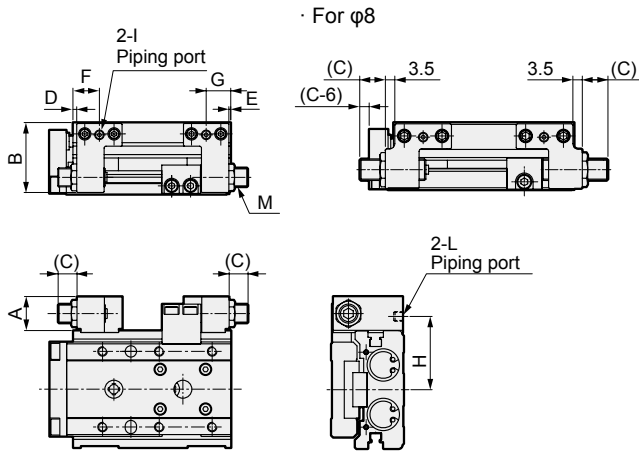

● Shock absorber stopper (A1 to A6)

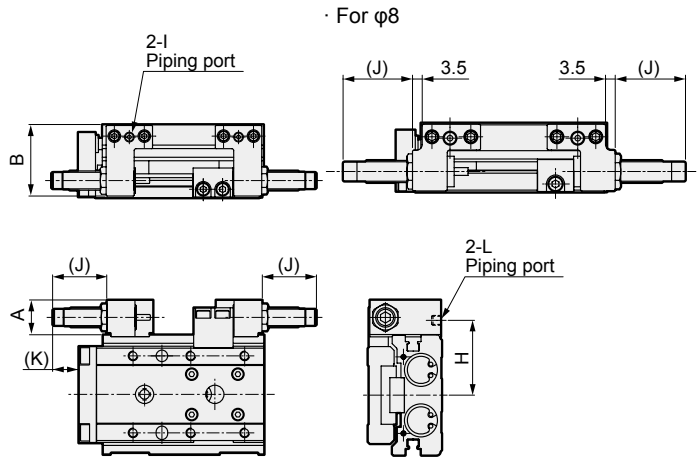

● Two-sided combined double stopper (W1 to W6)

· For $\phi 8$

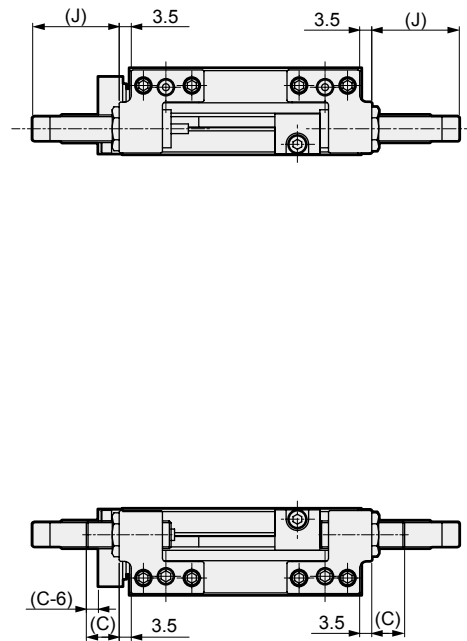
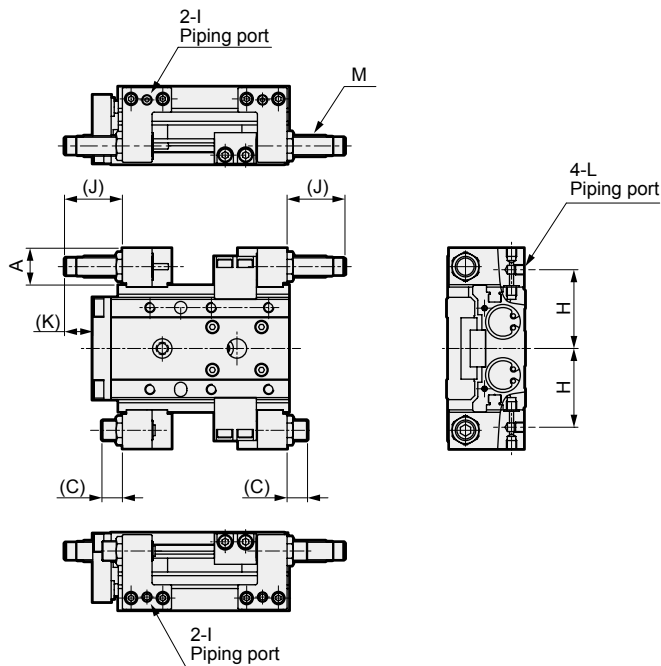

*1: F, G, H, I and L dimensions are only for the types with port on the stopper (S*D*, A*D*W*, W3** to W6**, C*D*).

2: For one side mixed type stopper mix (C), refer to the stroke adjusting stopper (S*) and shock absorber stopper (A*).

*3: S3** to S6**, A3** to A6**W*, W3** to W6**, C** are not available for the position locking.

4: Dimension C is that of adjustable stroke range 15 mm for two-sided combined double stopper (W).

Code	Bore size (mm)	A	B	C			D	E	F	G	H	I	J	K	L	Shock absorber stopper adjustable stroke range (one side)	M
				Adjustable stroke range													
				5 mm	15 mm	25 mm											
$\phi 6$	14	19.9	11	21	-	4	1	13.5	10.5	24	M3 depth 3	21	9	M3 depth 3	9	M8×0.75	
$\phi 8$	15.6	24.5	9.5	19.5	-	0.5	0.5	11	11	27.3	M5 depth 4	25	15.5	M5 depth 4	13.5	M8×0.75	
$\phi 12$	15.5	29	12	22	32	1	1	13	13	31	M5 depth 4	25	12	M5 depth 4	14.5	M8×0.75	
$\phi 16$	18	37	10	20	30	2	1	14	13	38.5	M5 depth 4	28.5	14	M5 depth 4	15	M10×1	
$\phi 20$	20.5	45.5	14.5	24.5	34.5	4	2.5	20.5	19	47	Rc1/8	28.5	9.5	M5 depth 4	13	M12×1	
$\phi 25$	20.5	57	11.5	21.5	31.5	2.5	2.5	19	19	54.5	Rc1/8	25.5	8	M5 depth 4	10	M12×1	

Dimensions: Option



● With buffer (B, BL)

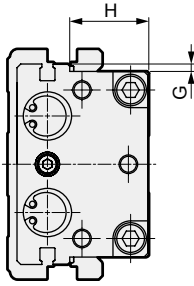

Option code: BL

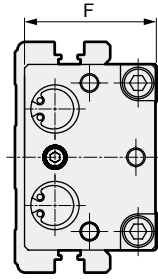

Option code: B

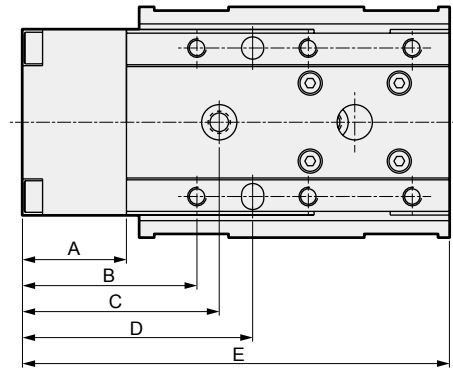

Code	A	B	C									D
			Stroke length (mm)									
			10	20	30	40	50	75	100	125	150	
φ6	22.5	34	45	45	42.5	43.5	45	-	-	-	-	41.5
φ8	21.5	34.5	42.5	42.5	42.5	41	42.5	39.5	-	-	-	44.5
φ12	27	44	55.5	55.5	55.5	54	50	52.5	65	-	-	56.5
φ16	28	47	53	53	53	64.5	54.5	58	56	68	-	62
φ20	31	52	65	65	65	71	69	66	66	73	71	69.5
φ25	34	55	65.5	65.5	65.5	68.5	83.5	83	78	68	83	72.5

Code	E									F	G	H
	Stroke length (mm)											
	10	20	30	40	50	75	100	125	150			
φ6	82.5	82.5	92.5	112.5	122.5	-	-	-	-	20	3.5	11.2
φ8	80.5	80.5	90.5	109.5	119.5	144.5	-	-	-	23.5	3.2	13.5
φ12	109	109	109	119	129	163	188	-	-	29	3.2	16
φ16	115	115	115	125	135	177	202	227	-	35.5	1	21.3
φ20	130.5	130.5	130.5	140.5	150.5	187	212	237	262	45.5	4	24.5
φ25	145.5	145.5	145.5	155.5	165.5	211	236	261	286	56	-	-

*1 : The dimensions not listed are the same as those of the standard.

*2 : When using rear piping, refer to the cautions of [1. Common; when piping](#) on page 133.

- LCW
- LCR**
- LCG
- LCX
- LCM
- STM
- STG
- STS/STL
- STR2
- UCA2
- ULK*
- JSK/M2
- JSG
- JSC3/JSC4
- USSD
- UFCD
- USC
- JSB3
- LMB
- LML
- HCM
- HCA
- LBC
- CAC4
- UCAC2
- CAC-N
- UCAC-N
- RCC2
- RCS
- PCC
- SHC
- MCP
- GLC
- MFC
- BBS
- RRC
- GRC
- RV3*
- NHS
- HR
- LN
- Hand
- Chuk
- MecHnd/Chuk
- ShkAbs
- FJ
- FK
- SpdContr
- Ending

LCW
LCR
 LCG
 LCX
 LCM
 STM
 STG
 STS/STL
 STR2
 UCA2
 ULK*
 JSK/M2
 JSG
 JSC3/JSC4
 USSD
 UFCD
 USC
 JSB3
 LMB
 LML
 HCM
 HCA
 LBC
 CAC4
 UCAC2
 CAC-N
 UCAC-N
 RCC2
 RCS
 PCC
 SHC
 MCP
 GLC
 MFC
 BBS
 RRC
 GRC
 RV3*
 NHS
 HR
 LN
 Hand
 Chuk
 MecHnd/Chuk
 ShkAbs
 FJ
 FK
 SpdContr
 Ending

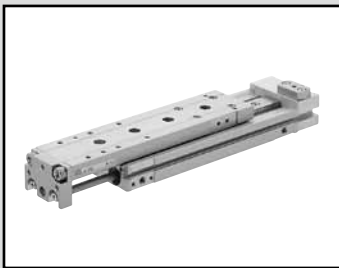

Linear slide cylinder Double acting/position locking

LCR-Q Series

● Bore size: $\phi 8/\phi 12/\phi 16/\phi 20/\phi 25$

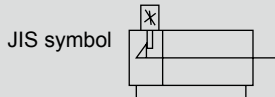

Specifications

Descriptions		LCR-Q				
Bore size	mm	$\phi 8$	$\phi 12$	$\phi 16$	$\phi 20$	$\phi 25$
Actuation		Double acting				
Working fluid		Compressed air				
Max. working pressure	MPa	0.7 (≈ 100 psi, 7 bar)				
Min. working pressure	MPa	0.15 (≈ 22 psi, 1.5 bar)				
Proof pressure	MPa	1.05 (≈ 150 psi, 10.5 bar)				
Ambient temperature	$^{\circ}\text{C}$	-10 (14°F) to 60 (140°F) (no freezing)				
Port size	Main body side	M5			Rc1/8	
	Main body back	None				
Stroke tolerance	mm	+2.0 0 (*1)				
Working piston speed	mm/s	50 to 500				
Cushion		With rubber cushion				
Position locking mechanism		Head side				
Holding force	N	At PULL, theoretical thrust $\times 0.7$ (at 0.7 MPa (≈ 100 psi, 7 bar))				
Lubrication		Not required (use turbine oil class 1 ISO VG32 if necessary for lubrication)				
Allowable absorbed energy	J	Refer to Table 3 on page 124.				

*1: Note that there will be a slight gap between the end plate and floating bush if no stopper is attached.

*2: The stroke adjusting stopper for 0.3 MPa and over working pressure is the metal sealing.

Stroke length

Bore size (mm)	Standard stroke length (mm)
$\phi 8$	10, 20, 30, 40, 50, 75
$\phi 12$	10, 20, 30, 40, 50, 75, 100
$\phi 16$	10, 20, 30, 40, 50, 75, 100, 125
$\phi 20$	10, 20, 30, 40, 50, 75, 100, 125, 150
$\phi 25$	10, 20, 30, 40, 50, 75, 100, 125, 150

Note: Products with stroke lengths other than the above are not available.

With buffer specifications Specifications other than the below are same as the above common specifications.

Descriptions		Content				
Bore size	mm	$\phi 8$	$\phi 12$	$\phi 16$	$\phi 20$	$\phi 25$
Buffer stroke length	mm	4	9		10	
Buffer part	Set	5	10	13	17	21
	spring load	Operating N	8	14	20	25

*1: In the type with buffer, adjusting the rod side stroke length will shorten the buffer stroke length and increase the spring load when set.

*2: Keep the buffer stroke length less than the stroke length above. Otherwise, malfunctions or damage may result.

Theoretical thrust table

Refer to page 125.

Switch specifications

- 1-color/2-color display

Descriptions	Reed 2-wire				Proximity 2-wire		Proximity 3-wire			
	T0H/T0V		T5H/T5V		T2H/T2V	T2WH/T2WV	T3H/T3V	T3PH/T3PV (custom)	T3WH/T3WV	
Applications	For programmable controller, relay		For programmable controller, relay, IC circuit (without indicator lamp), serial connection		Dedicated for programmable controller		For programmable controller, relay			
Output method	-		-		-		NPN output	PNP output	NPN output	
Power supply voltage	-		-		-		10 to 28 VDC			
Load voltage	12/24 VDC	110 VAC	5/12/24 VDC	110 VAC	10 to 30 VDC	24 VDC ±10%	30 VDC or less			
Load current	5 to 50 mA	7 to 20 mA	50 mA or less	20 mA or less	5 to 20 mA		100 mA or less	50 mA or less		
Indicator lamp	LED (Lit when ON)		Without indicator lamp		LED (Lit when ON)	Red/green LED (Lit when ON)	LED (Lit when ON)	Yellow LED (Lit when ON)	Red/green LED (Lit when ON)	
Leakage current	0 mA				1 mA or less		10 µA or less			
Weight	g				1 m:18 3 m:49 5 m:80					

Descriptions	Proximity 2-wire		Proximity 3-wire		Proximity 2-wire		Proximity 3-wire		
	F2S		F3S		F2H/F2V	F2YH/F2YV	F3H/F3V	F3PH/F3PV (custom order)	F3YH/F3YV
Applications	Dedicated for programmable controller		For programmable controller, relay		Dedicated for programmable controller		For programmable controller, relay		
Output method	-		NPN output		-		NPN output	PNP output	NPN output
Power supply voltage	-		10 to 28 VDC		-		10 to 28 VDC	4.5 to 28 VDC	10 to 28 VDC
Load voltage	10 to 30 VDC		30 VDC or less		10 to 30 VDC	24 VDC ±10%	30 VDC or less		
Load current	5 to 20 mA		50 mA or less		5 to 20 mA		100 mA or less	50 mA or less	
Indicator lamp	LED (Lit when ON)		LED (Lit when ON)		Yellow LED (Lit when ON)	Red/green LED (Lit when ON)	Yellow LED (Lit when ON)		Red/green LED (Lit when ON)
Leakage current	1 mA or less		10 µA or less		1 mA or less		10 µA or less		
Weight	g		1 m:10 3 m:29						

*1 : The T0/T5 switch can also be used with 220 VAC. Contact CKD about working conditions.

*2 : Refer to Ending Page 1 for other switch specifications.

*3 : Dimensions depend on switch model No. Refer to Ending Pages 18 and 23 for details.

Cylinder weight

- Position locking

(Unit: g)

Bore size (mm)	Basic Stroke length (mm)								
	10	20	30	40	50	75	100	125	150
φ8	260	260	280	330	360	420	-	-	-
φ12	415	425	425	465	495	625	715	-	-
φ16	670	680	680	730	790	1,020	1,150	1,290	-
φ20	1,150	1,160	1,170	1,250	1,340	1,640	1,850	2,060	2,270
φ25	2,000	2,020	2,030	2,140	2,240	2,730	3,000	3,270	3,540

- Additional weight of options

(Unit: g)

Bore size (mm)	Option/stopper code		With buffer
	S1/S2	A1/A2	B/BL
φ8	40	50	40
φ12	70	80	70
φ16	110	120	80
φ20	170	180	150
φ25	290	300	320

Specifications for rechargeable battery (Catalog No. CC-1226A)

LCR - ... -

P4*

- Design compatible with rechargeable battery manufacturing process.

* Contact CKD for details.

LCW
LCR
LCG
LCX
LCM
STM
STG
STS/STL
STR2
UCA2
ULK*
JSK/M2
JSG
JSC3/JSC4
USSD
UFCD
USC
JSB3
LMB
LML
HCM
HCA
LBC
CAC4
UCAC2
CAC-N
UCAC-N
RCC2
RCS
PCC
SHC
MCP
GLC
MFC
BBS
RRC
GRC
RV3*
NHS
HR
LN
Hand
Chuk
MecHnd/Chuk
ShkAbs
FJ
FK
SpdContr
Ending

LCR-Q Series

How to order

Without switch (built-in magnet for switch)

LCR-Q - 8 - 40 - S202 DTBL

With switch (built-in magnet for switch)

LCR-Q - 12 - 40 - F2H* - R - S202 DTBL

Model No.

A Bore size

B Stroke length

D Switch quantity

F Option

C Switch model No.

E Stopper

⚠ Precautions for model No. selection

- *1 : For the adjustable stroke range with a shock absorber stopper, refer to the stopper dimensions table on page 84.
- *2 : For the port position, refer to the stopper dimensions on page 84.
- *3 : The port position of the standard without stopper is the ① side in the figure below.
- *4 : Combination of the stroke adjusting stopper and shock absorber stopper is custom order.
- *5 : Can be selected for the type with stopper only.
- *6 : A switch for buffer should be purchased separately. Refer to how to order a switch on page 90.
- *7 : Refer to the selection table on page 89 for combinations of options.
- *8 : A1** and A2** of $\phi 8$ with 10 mm stroke length or less and $\phi 12$ to $\phi 25$ with 20 mm stroke length or less are custom order since adjustment is not possible with the standard stopper.
- *9 : The adjustable stroke range when choosing two-sided combined (W) is $\phi 8$: 13.5 mm, $\phi 12$: 14.5 mm, $\phi 16$: 15 mm, $\phi 20$: 13 mm, $\phi 25$: 10 mm.
- *10 : The stroke adjusting stopper for 0.3 MPa and over working pressure is the metal sealing.

[Example of model No.]

LCR-Q-12-40-F2H-R-A1D

Model: Linear slide cylinder Double acting/position locking LCR-Q

- A** Bore size : $\phi 12$
- B** Stroke length : 40 mm
- C** Switch model No. : Proximity/2-wire Axial lead wire
- D** Switch quantity : 1 on rod side
- E** Stopper : Shock absorber stopper stopper position ①
- F** Option : With side and bottom ports Material, alloy steel (nitriding)

● Stopper position

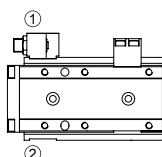

Code	Content
A Bore size	
8	$\phi 8$
12	$\phi 12$
16	$\phi 16$
20	$\phi 20$
25	$\phi 25$

		Bore size (ϕ)				
		8	12	16	20	25
B Stroke length (mm)	10	●	●	●	●	●
	20	●	●	●	●	●
	30	●	●	●	●	●
	40	●	●	●	●	●
	50	●	●	●	●	●
	75	●	●	●	●	●
	100		●	●	●	●
	125			●	●	●
	150				●	●

C Switch model No.							Bore size				
Axial lead wire	Radial lead wire	Contact	Voltage AC DC	Indicator lamp	Lead wire						
F2S*		●	●	1-color	2-wire						
F3S*		●	●	display	3-wire						
F2H*	F2V*	●	●	display	2-wire						
F3H*	F3V*	●	●	display	3-wire	●	●				
F3PH*	F3PV*	●	●	1-color display (PNP output) (custom)	3-wire						
F2YH*	F2YV*	●	●	2-color	2-wire						
F3YH*	F3YV*	●	●	display	3-wire						
T0H*	T0V*	●	●	1-color display	2-wire						
T5H*	T5V*	●	●	no indicator lamp	2-wire						
T2H*	T2V*	●	●	1-color	2-wire						
T3H*	T3V*	●	●	display	3-wire						
T3PH*	T3PV*	●	●	1-color display (PNP output) (custom)	3-wire			●	●	●	
T2WH*	T2WV*	●	●	2-color	2-wire						
T3WH*	T3WV*	●	●	display	3-wire						

* Lead wire length	
Blank	1 m (standard)
3	3 m (option)
5	5 m (option)

D Switch quantity	
R	1 on rod side
H	1 on head side
D	2

E Stopper	
Blank	No option
S Stroke adjusting stopper *9	
S1**	Stopper position ①
S2**	Stopper position ②
A Shock absorber stopper	
A1**	Stopper position ①
A2**	Stopper position ②
W Two-sided combined double stopper (shock absorber stopper, metal stopper) *9/*10	
W1**	A1 + metal stopper
W2**	A2 + metal stopper
** part	Adjustable stroke range
	Protruding end
	Stopper model No.
	S A W
Blank	5 mm
02	15 mm
03	25 mm

F Option	
Blank	Port on the stopper: without port
D	Port on the stopper: side and bottom ports *2, *5
Blank	Stopper block material: steel
T	Stopper block material: steel (nitriding) *5
B With buffer *6, *7	
B	Without switch groove
BL	With switch groove

Stopper model No. selection method

1 Stopper combination table

Model No.-[①Stopper] [②Stopper position] [③] Example) LCR-Q-8-40-[S] [2] 06

Stopper position model No. [②]		Stroke adjustable (one side)		Shock absorber (one side)		Two-sided combined double stopper	
		Stopper model No. [①]					
		[S]	[A]	[W]			
[1]	[S1]		[A1]		[W1]		
	[S2]		[A2]		[W2]		
[2]	[S1]		[A1]		[W1]		
	[S2]		[A2]		[W2]		

▲ shows the piping direction.
If two-sided combined (W) is selected, the stopper bracket comes with piping on both sides, ▲ (piping direction) and the reverse side stopper bracket comes with a plug.

■: Shock absorber stopper
■: Stroke adjusting stopper (adjusting range 5 mm)
■: Metal adjusting stopper (adjusting range 15 mm)

2 Stopper combination table

Model No.-[①②Stopper][③Adjustable stroke range]

Example) LCR-Q-8-40-S1[02]

For stroke adjusting stopper -S

Adjustable stroke range model No. [③]		Stopper adjusting range		Stopper model No. [①②]			
		Protruding end		[S1]	[S2]		
[03]	Blank	5 mm					
	[02]	15 mm					
	[03]	25 mm					

■: Stroke adjusting stopper (adjusting range 5 mm)
■: Stroke adjusting stopper (adjusting range 15 mm)
■: Stroke adjusting stopper (adjusting range 25 mm)

▲ shows the piping direction.
Cannot be selected for shock absorber [A] and two-sided combined [W].

LCR-Q position locking selection table

(Combination with stroke adjusting stopper, shock absorber stopper)

●: Available —: Not available

Option code		Stroke adjusting stopper						Shock absorber stopper				Two-sided combined double stopper	
Bore size	Stroke length	S1			S2			A1	A2	W1	W2		
		Adjustment length code											
		Blank	02	03	Blank	02	03						
φ8	10	●	—	—	●	—	—	—	—	—	—		
	20 or more	●	●	—	●	●	—	●	●	●	●		
φ12 to φ25	10	●	—	—	●	—	—	—	—	—	—		
	20	●	●	—	●	●	—	—	—	—	—		
	30 or more	●	●	●	●	●	●	●	●	●	●		

The table above also applies to a combination with option code D (with port on the stopper) or T (alloy steel stopper block (nitriding)).

- LCW
- LCR
- LCG
- LCX
- LCM
- STM
- STG
- STS/STL
- STR2
- UCA2
- ULK*
- JSK/M2
- JSG
- JSC3/JSC4
- USSD
- UFCD
- USC
- JSB3
- LMB
- LML
- HCM
- HCA
- LBC
- CAC4
- UCAC2
- CAC-N
- UCAC-N
- RCC2
- RCS
- PCC
- SHC
- MCP
- GLC
- MFC
- BBS
- RRC
- GRC
- RV3*
- NHS
- HR
- LN
- Hand
- Chuk
- MecHnd/Chuk
- ShkAbs
- FJ
- FK
- SpdContr
- Ending

How to order switch

For $\phi 8$ to $\phi 12$

SW - F2H

Switch model No.
(Item © on page 88)

For $\phi 16$ to $\phi 25$

SW - T2H3

Switch model No.
(Item © on page 88)

● Buffer part

SW - F 2 V 3

Output

Output	
2	DC 2-wire proximity
3	DC 3-wire proximity
Radial lead wire	
Lead wire length	
Blank	1 m (standard)
3	3 m (option)

How to order a stopper set

- Set of a stopper and stroke adjusting stopper or shock absorber stopper
- Use it when changing from the standard to the stroke adjusting stopper or shock absorber stopper.

LCR - 12 - S 2 D - S02

Bore size
(Item A on page 88)

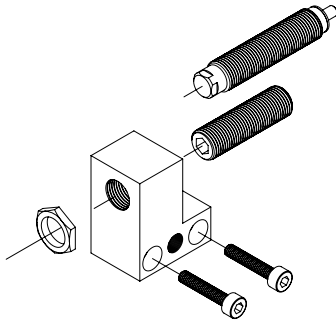

A Stopper	
S	Stroke adjusting stopper
A	Shock absorber stopper
B Stopper installation position *1	
1	Stopper position ①
2	Stopper position ②
C Port on the stopper	
Blank	Without port
D	With side and bottom ports
D Adjustable stroke length *2/*3	
Blank	Adjustable stroke range 5 mm
S02	Adjustable stroke range 15 mm
S03	Adjustable stroke range 25 mm

- *1: The adjustable stroke length changes depending on the stroke; see the table below.
 *2: $\phi 8$ is not available for S03.
 *3: Cannot be selected for the shock absorber stopper "A".

Note) Bottom port is plug-sealed.
 When using the bottom port with $\phi 20$ and 25, buy a plug kit (LCR-20-N 2 pieces/set) and seal the side surface ports before using.

Precautions when purchasing the stopper set

Note that the adjustable stroke length will be as shown on the right according to the stroke length.

Model No. code	Option code		Discrete stroke adjusting stopper		
	Bore size	Stroke length	Adjustable stroke length (mm)		
			-5	-15	-25
LCR-Q Series	$\phi 8$	10	S02	—	—
		20 or more	Blank	S02	—
	$\phi 12$ to $\phi 25$	10	S03	—	—
		20	S02	S03	—
	30 or more	Blank	S02	S03	

—: Not applicable

● Stopper set weight

(Unit: g)

Stopper	S1,S2			A1,A2
Port on the stopper	Blank, D			
Adjustable stroke length	Blank	S02	S03	Blank
$\phi 8$	21	25	—	27
$\phi 12$	28	31	34	33
$\phi 16$	42	47	52	49
$\phi 20$	77	85	92	86
$\phi 25$	87	94	101	95

How to order discrete stopper bracket

- Used when changing between □1 and □2 or when changing to the stopper with port.
□:SA

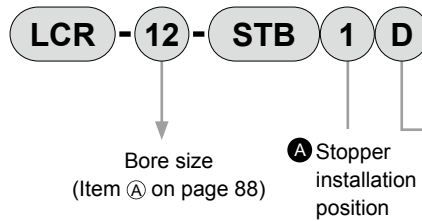
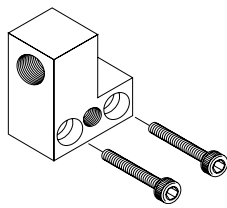

A Stopper installation position	
1	Stopper position ①
2	Stopper position ②

B Port on the stopper	
Blank	Without port
D	With side and bottom ports

Note) Bottom port is plug-sealed.
When using the bottom port with φ20 and 25, buy a plug kit (LCR-20-N 2 pieces/set) and seal the side surface ports before using.

- Stopper bracket weight (Unit: g)

Stopper installation position	1,2
Port on the stopper	Blank, D
φ8	14
φ12	20
φ16	29
φ20	53
φ25	62

How to order discrete stroke adjusting stopper

- Hexagon socket set screw with urethane
- Use when changing the adjustable stroke range or when using a custom stroke length.

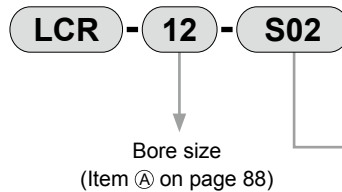
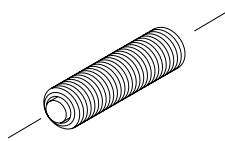

A Adjustable stroke range	
S01	Single side 5 mm (standard)
S02	Single side 15 mm
S03	Single side 25 mm

Select S01, S02 or S03 in ①.
Note: S03 is not available for φ8.
Some models may not be available and adjustable stroke range may differ from the above depending on the model No.

Precautions when purchasing discrete stopper

Note that the combination will be as shown on the right according to the stroke length and adjustable stroke length.

Model No. code	Option code		Discrete stroke adjusting stopper			Discrete shock absorber stopper
	Bore size	Stroke length	Adjustable stroke length (mm)			
LCR Series -S1, S2 -A1, A2	φ8	10	S02	—	—	—
		20 or more	S01	S02	—	A01
	φ12 to φ25	10	S03	—	—	—
		20	S02	S03	—	—
		30 or more	S01	S02	S03	—
		30 or more	S01	S02	S03	A01

- Discrete stroke adjusting stopper weight (Unit: g)

Adjustable stroke range	S01	S02	S03
φ8	7	10	—
φ12	7	11	14
φ16	11	16	22
φ20	22	30	37
φ25	23	30	37

- LCW
- LCR
- LCG
- LCX
- LCM
- STM
- STG
- STS/STL
- STR2
- UCA2
- ULK*
- JSK/M2
- JSG
- JSC3/JSC4
- USSD
- UFCD
- USC
- JSB3
- LMB
- LML
- HCM
- HCA
- LBC
- CAC4
- UCAC2
- CAC-N
- UCAC-N
- RCC2
- RCS
- PCC
- SHC
- MCP
- GLC
- MFC
- BBS
- RRC
- GRC
- RV3*
- NHS
- HR
- LN
- Hand
- Chuk
- MecHnd/Chuk
- ShkAbs
- FJ
- FK
- SpdContr
- Ending

- LCW
- LCR**
- LCG
- LCX
- LCM
- STM
- STG
- STS/STL
- STR2
- UCA2
- ULK*
- JSK/M2
- JSG
- JSC3/JSC4
- USSD
- UFCD
- USC
- JSB3
- LMB
- LML
- HCM
- HCA
- LBC
- CAC4
- UCAC2
- CAC-N
- UCAC-N
- RCC2
- RCS
- PCC
- SHC
- MCP
- GLC
- MFC
- BBS
- RRC
- GRC
- RV3*
- NHS
- HR
- LN
- Hand
- Chuk
- MecHnd/Chuk
- ShkAbs
- FJ
- FK
- SpdContr
- Ending

How to order discrete shock absorber stopper

- Shock absorber set
- Use when changing from the stroke adjusting stopper or shock absorber stopper.

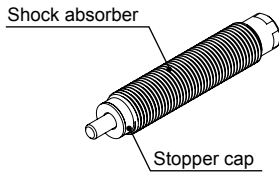

LCR - 12 - A01

Bore size
(Item A on page 88)

Note: Some models may not be available depending on the specifications. Refer to page 88.
Note: For the adjustable stroke range with a shock absorber stopper, refer to page 88.

Applicable shock absorber model No.

Model	Shock absorber model No.	Weight (g)
LCR-8	SKL-0805	12
LCR-12	SKL-0805	12
LCR-16	SKL-1006	19
LCR-20	SKL-1208	31
LCR-25	SKL-1208	31

How to order discrete stopper block

- Use it when changing from the standard to the stroke adjusting stopper or shock absorber stopper.

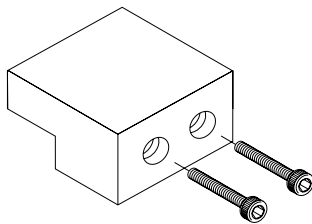

LCR - 12 - SB1 T

Bore size
(Item A on page 88)

A Stopper block	
SB1	φ8: For 30 mm stroke length or less φ12 to φ25: For 50 mm stroke length or less
SB2	φ8: For 40 mm stroke length or more φ12 to φ25: For 75 mm stroke length or more
B Material	
Blank	Stopper block material: steel
T	Stopper block material: steel (nitriding)

Internal structure and parts list

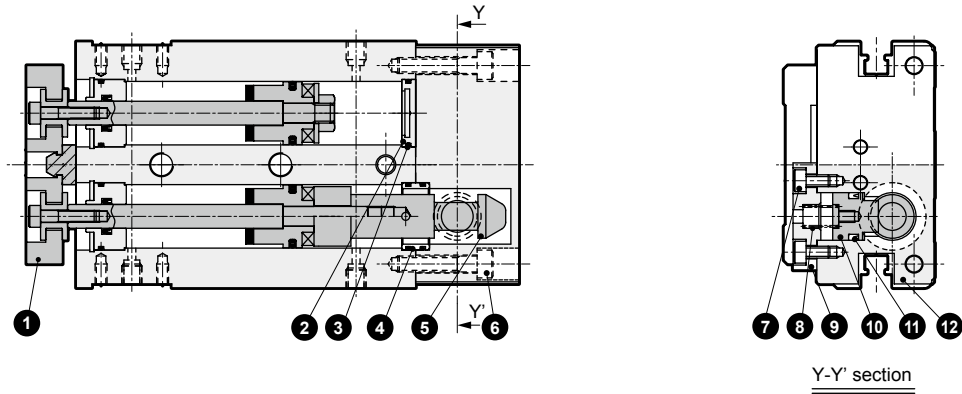

Parts list

No.	Part name	Material	Remarks	No.	Part name	Material	Remarks
1	End plate	Aluminum alloy	Alumite	7	Hexagon socket head cap screw	Alloy steel	Zinc chromate
2	Cover	Aluminum alloy		8	Coil spring	Steel	
3	Gasket	Nitrile rubber		9	Stopper cover	Aluminum alloy	Alumite
4	Joint ring	φ8: Stainless steel φ12 to 25: Aluminum alloy	φ12 to φ25: Chromate	10	Stopper piston	Carbon steel	Nitriding
5	Sleeve	Carbon steel	Nitriding	11	Stopper packing	Nitrile rubber	
6	Hexagon socket head cap screw	Alloy steel	Zinc chromate	12	Head cover	Aluminum alloy	Alumite

Repair parts list

Bore size (mm)	Kit No.	Repair parts No.	
		Repair parts for position locking	Basic parts are repair parts
φ8	LCR-Q-8K	11	
φ12	LCR-Q-12K		4 5 9
φ16	LCR-Q-16K		11 17 21
φ20	LCR-Q-20K		
φ25	LCR-Q-25K		

Note: The repair part numbers for the base section correspond to those in the double acting/single rod parts list on page 69.

- LCW
- LCR**
- LCG
- LCX
- LCM
- STM
- STG
- STS/STL
- STR2
- UCA2
- ULK*
- JSK/M2
- JSG
- JSC3/JSC4
- USSD
- UFCD
- USC
- JSB3
- LMB
- LML
- HCM
- HCA
- LBC
- CAC4
- UCAC2
- CAC-N
- UCAC-N
- RCC2
- RCS
- PCC
- SHC
- MCP
- GLC
- MFC
- BBS
- RRC
- GRC
- RV3*
- NHS
- HR
- LN
- Hand
- Chuk
- MecHnd/Chuk
- ShkAbs
- FJ
- FK
- SpdContr
- Ending

Dimensions



● LCR-Q

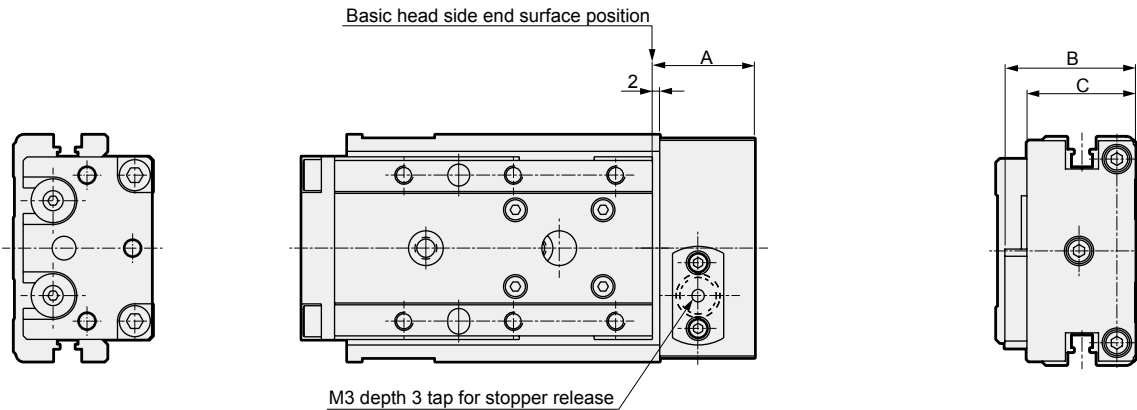

● LCR-Q-*-B (with buffer)

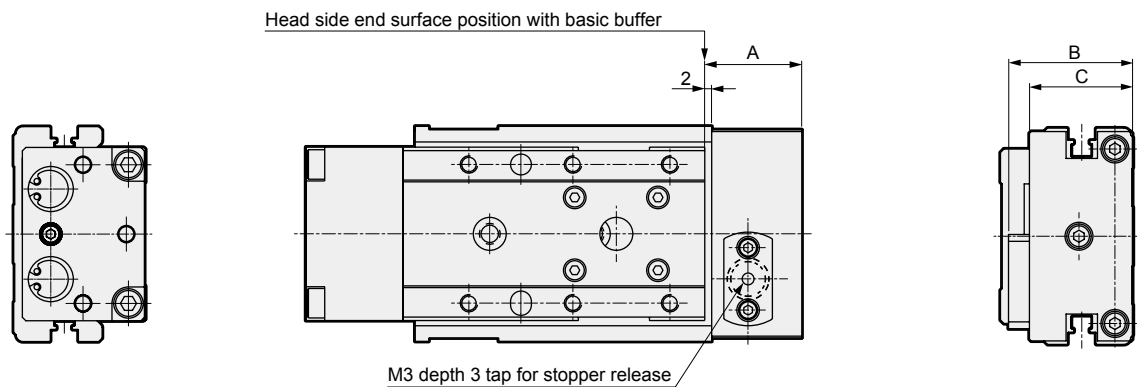

Code	A	B	C
Bore size (mm)			
φ8	23	28	22
φ12	24.5	30.5	24.5
φ16	28	35.7	29.7
φ20	30	39	33
φ25	30	48	42

Note: Dimensions other than those listed above are the same as those of double acting/single rod.

- LCW
- LCR
- LCG
- LCX
- LCM
- STM
- STG
- STS/STL
- STR2
- UCA2
- ULK*
- JSK/M2
- JSG
- JSC3/JSC4
- USSD
- UFCD
- USC
- JSB3
- LMB
- LML
- HCM
- HCA
- LBC
- CAC4
- UCAC2
- CAC-N
- UCAC-N
- RCC2
- RCS
- PCC
- SHC
- MCP
- GLC
- MFC
- BBS
- RRC
- GRC
- RV3*
- NHS
- HR
- LN
- Hand
- Chuk
- MecHnd/Chuk
- ShkAbs
- FJ
- FK
- SpdContr
- Ending

MEMO

LCW
LCR
LCG
LCX
LCM
STM
STG
STS/STL
STR2
UCA2
ULK*
JSK/M2
JSG
JSC3/JSC4
USSD
UFCD
USC
JSB3
LMB
LML
HCM
HCA
LBC
CAC4
UCAC2
CAC-N
UCAC-N
RCC2
RCS
PCC
SHC
MCP
GLC
MFC
BBS
RRC
GRC
RV3*
NHS
HR
LN
Hand
Chuk
MecHnd/Chuk
ShkAbs
FJ
FK
SpdContr
Ending

LCW
LCR
 LCG
 LCX
 LCM
 STM
 STG
 STS/STL
 STR2
 UCA2
 ULK*
 JSK/M2
 JSG
 JSC3/JSC4
 USSD
 UFCD
 USC
 JSB3
 LMB
 LML
 HCM
 HCA
 LBC
 CAC4
 UCAC2
 CAC-N
 UCAC-N
 RCC2
 RCS
 PCC
 SHC
 MCP
 GLC
 MFC
 BBS
 RRC
 GRC
 RV3*
 NHS
 HR
 LN
 Hand
 Chuk
 MecHnd/Chuk
 ShkAbs
 FJ
 FK
 SpdContr
 Ending

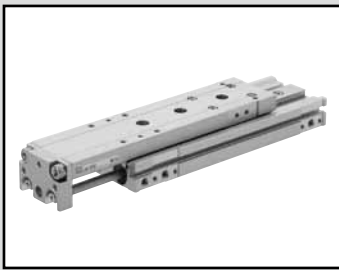

Linear slide cylinder Double acting/single rod clean-room specifications

LCR-P7* Series

● Bore size: $\phi 6/\phi 8/\phi 12/\phi 16/\phi 20/\phi 25$

JIS symbol

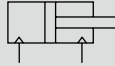

Specifications

Descriptions		LCR-P7*					
Bore size	mm	$\phi 6$	$\phi 8$	$\phi 12$	$\phi 16$	$\phi 20$	$\phi 25$
Actuation		Double acting					
Working fluid		Compressed air					
Max. working pressure	MPa	0.7 (≈ 100 psi, 7 bar)					
Min. working pressure	MPa	0.15 (≈ 22 psi, 1.5 bar)					
Proof pressure	MPa	1.05 (≈ 150 psi, 10.5 bar)					
Ambient temperature	$^{\circ}\text{C}$	-10 (14°F) to 60 (140°F) (no freezing)					
Port size	Main body side	M3	M5			Rc1/8	
	Main body back	-	M3	M5		Rc1/8	
Pressure relief port size		M3	M5			Rc1/8	
Stroke tolerance	mm	+2.0 0 (*1)					
Working piston speed	mm/s	50 to 500					
Cushion		With rubber cushion					
Lubrication		Not available					
Allowable absorbed energy	J	Refer to Table 3 on page 124.					

*1: Note that there will be a slight gap between the end plate and floating bush if no stopper is attached.

*2: The stroke adjusting stopper for 0.3 MPa and over working pressure is the metal sealing.

Stroke length

Bore size (mm)	Standard stroke length (mm)
$\phi 6$	10, 20, 30, 40, 50
$\phi 8$	10, 20, 30, 40, 50, 75
$\phi 12$	10, 20, 30, 40, 50, 75, 100
$\phi 16$	10, 20, 30, 40, 50, 75, 100, 125
$\phi 20$	10, 20, 30, 40, 50, 75, 100, 125, 150
$\phi 25$	10, 20, 30, 40, 50, 75, 100, 125, 150

Note: Products with stroke lengths other than the above are not available.

Theoretical thrust table

Refer to page 125.

Switch specifications

- 1-color/2-color display

Descriptions	Reed 2-wire				Proximity 2-wire		Proximity 3-wire		
	T0H/T0V		T5H/T5V		T2H/T2V	T2WH/T2WV	T3H/T3V	T3PH/T3PV (custom)	T3WH/T3WV
Applications	For programmable controller, relay		For programmable controller, relay, IC circuit (without indicator lamp), serial connection		Dedicated for programmable controller		For programmable controller, relay		
Output method	-		-		-		NPN output	PNP output	NPN output
Power supply voltage	-		-		-		10 to 28 VDC		
Load voltage	12/24 VDC	110 VAC	5/12/24 VDC	110 VAC	10 to 30 VDC	24 VDC ±10%	30 VDC or less		
Load current	5 to 50 mA	7 to 20 mA	50 mA or less	20 mA or less	5 to 20 mA		100 mA or less	50 mA or less	
Indicator lamp	LED (Lit when ON)		Without indicator lamp		LED (Lit when ON)	Red/green LED (Lit when ON)	LED (Lit when ON)	Yellow LED (Lit when ON)	Red/green LED (Lit when ON)
Leakage current	0 mA				1 mA or less		10 µA or less		
Weight	g 1 m:18 3 m:49 5 m:80								

Descriptions	Proximity 2-wire		Proximity 3-wire		Proximity 2-wire		Proximity 3-wire		
	F2S		F3S		F2H/F2V	F2YH/F2YV	F3H/F3V	F3PH/F3PV (custom order)	F3YH/F3YV
Applications	Dedicated for programmable controller		For programmable controller, relay		Dedicated for programmable controller		For programmable controller, relay		
Output method	-		NPN output		-		NPN output	PNP output	NPN output
Power supply voltage	-		10 to 28 VDC		-		10 to 28 VDC	4.5 to 28 VDC	10 to 28 VDC
Load voltage	10 to 30 VDC		30 VDC or less		10 to 30 VDC	24 VDC ±10%	30 VDC or less		
Load current	5 to 20 mA		50 mA or less		5 to 20 mA		100 mA or less	50 mA or less	
Indicator lamp	LED (Lit when ON)		LED (Lit when ON)		Yellow LED (Lit when ON)	Red/green LED (Lit when ON)	Yellow LED (Lit when ON)		Red/green LED (Lit when ON)
Leakage current	1 mA or less		10 µA or less		1 mA or less		10 µA or less		
Weight	g 1 m:10 3 m:29								

*1 : The T0/T5 switch can also be used with 220 VAC. Contact CKD about working conditions.

*2 : Refer to Ending Page 1 for other switch specifications.

*3 : Dimensions depend on switch model No. Refer to Ending Pages 18 and 23 for details.

Cylinder weight

- Clean-room specifications

(Unit: g)

Bore size (mm)	Basic Stroke length (mm)								
	10	20	30	40	50	75	100	125	150
φ6	130	130	150	180	200	-	-	-	-
φ8	220	220	240	290	320	380	-	-	-
φ12	400	410	410	450	480	610	700	-	-
φ16	620	630	630	680	740	970	1,100	1,240	-
φ20	1,160	1,170	1,180	1,260	1,350	1,650	1,860	2,070	2,280
φ25	2,010	2,030	2,040	2,150	2,250	2,740	3,010	3,280	3,550

- Weight of variation/option (stopper)

(Unit: g)

Bore size (mm)	Option/stopper code	
	S1 to S4	S5/S6
φ6	30	40
φ8	40	60
φ12	70	100
φ16	110	150
φ20	170	250
φ25	290	380

- LCW
- LCR
- LCG
- LCX
- LCM
- STM
- STG
- STS/STL
- STR2
- UCA2
- ULK*
- JSK/M2
- JSG
- JSC3/JSC4
- USSD
- UFCD
- USC
- JSB3
- LMB
- LML
- HCM
- HCA
- LBC
- CAC4
- UCAC2
- CAC-N
- UCAC-N
- RCC2
- RCS
- PCC
- SHC
- MCP
- GLC
- MFC
- BBS
- RRC
- GRC
- RV3*
- NHS
- HR
- LN
- Hand
- Chuk
- MecHnd/Chuk
- ShkAbs
- FJ
- FK
- SpdContr
- Ending

LCR-P7* Series

How to order

Without switch (built-in magnet for switch)

LCR - 8 - 40 - S506 DT P72

With switch (built-in magnet for switch)

LCR - 12 - 40 - F2H* - R - S506 DT P72

Model No.

A Bore size

B Stroke length

C Switch model No.

G Clean-room specifications

D Switch quantity

E Stopper

F Option

⚠ Precautions for model No. selection

- *1 : For the port position, refer to the stopper dimensions on page 112.
- *2 : The port positions of the standard without stopper are ① and ③ in the figure below.
- *3 : Can be selected for the type with stopper only.
- *4 : When two switches are necessary for the type with S*** of $\phi 6$ to $\phi 8$ with 30 mm stroke length or less, select the F □ H type switch.
- *5 : Select when using rear piping.
- *6 : The stroke adjusting stopper for 0.3 MPa and over working pressure is the metal sealing.
- *7 : When changing the stopper position from the head side to the rod side, the stopper must be purchased separately according to the stroke length and adjustable stroke length. Refer to "Precautions when purchasing discrete stopper" on page 67. Adjustable stroke lengths of 15 mm and 25 mm may not be possible depending on the stroke length.

[Example of model No.]

LCR-12-40-F2H*-R-S1DT-P72

Model: Linear slide cylinder Double acting/single rod (clean-room specifications) LCR-P7*

- A Bore size : $\phi 12$
- B Stroke length : 40 mm
- C Switch model No.: Proximity/2-wire Axial lead wire
- D Switch quantity : 1 on rod side
- E Stopper : Stroke adjusting stopper Stopper position ①
- F Option : Port on the stopper: Side and bottom ports Stopper block material: steel (nitriding)
- G Clean-room specifications : Exhaust port

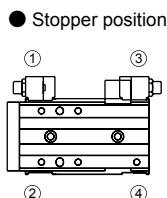

Code	Content
A Bore size	
6	$\phi 6$
8	$\phi 8$
12	$\phi 12$
16	$\phi 16$
20	$\phi 20$
25	$\phi 25$

		Bore size (ϕ)					
		6	8	12	16	20	25
10	10	●	●	●	●	●	●
20	20	●	●	●	●	●	●
30	30	●	●	●	●	●	●
40	40	●	●	●	●	●	●
50	50	●	●	●	●	●	●
75	75		●	●	●	●	●
100	100			●	●	●	●
125	125				●	●	●
150	150					●	●

		C Switch model No.									
Axial lead wire	Radial lead wire	Contact	Voltage AC DC	Indicator lamp	Lead wire	Bore size					
						$\phi 6$	$\phi 8$	$\phi 12$	$\phi 16$	$\phi 20$	$\phi 25$
F2S*		Proximity	●	1-color display	2-wire						
F3S*			●		3-wire						
F2H*	F2V*	Proximity	●	2-color display	2-wire						
F3H*	F3V*		●		3-wire						
F3PH*	F3PV*	Proximity	●	1-color display (PNP output) (custom)	3-wire	●	●	●			
F2YH*	F2YV*		●		2-wire						
F3YH*	F3YV*	Reed	●	2-color display	3-wire						
T0H*	T0V*		●		2-wire						
T5H*	T5V*	Proximity	●	1-color display	2-wire						
T2H*	T2V*		●		3-wire						
T3H*	T3V*	Proximity	●	1-color display (PNP output) (custom)	3-wire				●	●	●
T3PH*	T3PV*		●		2-wire						
T2WH*	T2WV*	Proximity	●	2-color display	2-wire						
T3WH*	T3WV*		●		3-wire						

Lead wire length							
Blank	1 m (standard)						●
3	3 m (option)						●
5	5 m (option)						●

D Switch quantity							
R	1 on rod side						●
H	1 on head side						●
D	2						●

E Stopper							
Blank	No option						●

S Stroke adjusting stopper		5 mm stroke adjustment on one side *4					
S1**	Stopper position ① (can be changed to ④)	Stopper installation position					●
S2**	Stopper position ② (can be changed to ③)						●
S3**	Stopper position ③ (can be changed to ②) *7						●
S4**	Stopper position ④ (can be changed to ①) *7						●
S5**	Stopper position ①, ③						●
S6**	Stopper position ②, ④						●

** part	Adjustable stroke range	Return end	Compatible with all. ▲ Compatible with some. *3			
	Protruding end	Return end				
Blank	5 mm or none	5 mm or none				●
02	15 mm or none	15 mm or none				●
03	25 mm or none	25 mm or none				●
04	15 mm	5 mm				▲
05	25 mm	5 mm				▲
06	5 mm	15 mm				▲
07	5 mm	25 mm				▲

F Option							
Blank	Port on the stopper: without port						●
D	Port on the stopper: side and bottom ports						● *1, *3
Blank	Stopper block material: steel						●
T	Stopper block material: steel (nitriding)						● *3

Plug attached							
Blank	None						
N	With side piping port plug (not available for $\phi 6$, $\phi 25$) *5						

G Clean-room specifications		Structure					
P72	Exhaust port						
P73	Vacuum treatment						

Stopper model No. selection method

Stopper combination table

Model No.-[① ② Stopper] [③ Adjustable stroke range]

Example) LCR-8-40- [S5] [06]-P7*

For stroke adjusting stopper -S

Adjustable stroke range Model No. [③]	Stopper adjusting range		Stopper model No. [① ②]							
	Protruding end	Return end	[S1]	[S2]	[S3]	[S4]	[S5]	[S6]		
	Blank	5 mm or none	5 mm or none							
[02]	15 mm or none	15 mm or none								
[03]	25 mm or none	25 mm or none								
[04]	15 mm	5 mm								
[05]	25 mm	5 mm								
[06]	5 mm	15 mm								
[07]	5 mm	25 mm								

- : Stroke adjusting stopper (adjusting range 5 mm)
- : Stroke adjusting stopper (adjusting range 15 mm)
- : Stroke adjusting stopper (adjusting range 25 mm)

▲ shows the piping direction.

- LCW
- LCR
- LCG
- LCX
- LCM
- STM
- STG
- STS/STL
- STR2
- UCA2
- ULK*
- JSK/M2
- JSG
- JSC3/JSC4
- USSD
- UFCD
- USC
- JSB3
- LMB
- LML
- HCM
- HCA
- LBC
- CAC4
- UCAC2
- CAC-N
- UCAC-N
- RCC2
- RCS
- PCC
- SHC
- MCP
- GLC
- MFC
- BBS
- RRC
- GRC
- RV3*
- NHS
- HR
- LN
- Hand
- Chuk
- MecHnd/Chuk
- ShkAbs
- FJ
- FK
- SpdContr
- Ending

Selection table

●: Available —: Not available

Bore size (mm)		Stopper code																																									
		S1							S2							S3							S4							S5							S6						
		Adjustment length code																																									
		Blank	02	03	Blank	02	03	Blank	02	03	Blank	02	03	Blank	02	03	Blank	02	03	04	05	06	07	Blank	02	03	04	05	06	07													
φ6,φ8	10st	●	—	—	●	—	—	●	●	—	●	●	—	●	—	—	—	—	—	—	—	●	—	●	—	—	—	—	●	—													
	20st up	●	●	—	●	●	—	●	●	—	●	●	—	●	●	—	●	—	●	—	●	—	●	●	—	●	—	●	—	—													
φ12 to φ25	10st	●	—	—	●	—	—	●	●	—	●	●	—	●	—	—	—	—	—	—	—	●	—	●	—	—	—	—	●	—													
	20st	●	●	—	●	●	—	●	●	—	●	●	—	●	●	—	●	—	●	—	●	—	●	●	—	●	—	●	—	—													
	30st up	●	●	●	●	●	—	●	●	—	●	●	—	●	●	—	●	—	●	—	●	—	●	●	—	●	—	●	—	—													

Dimensions (bore size: $\phi 6$)



● LCR-6-P7*

Stroke length: 40, 50

(Body mounting hole in the figure shows 50 mm stroke length)

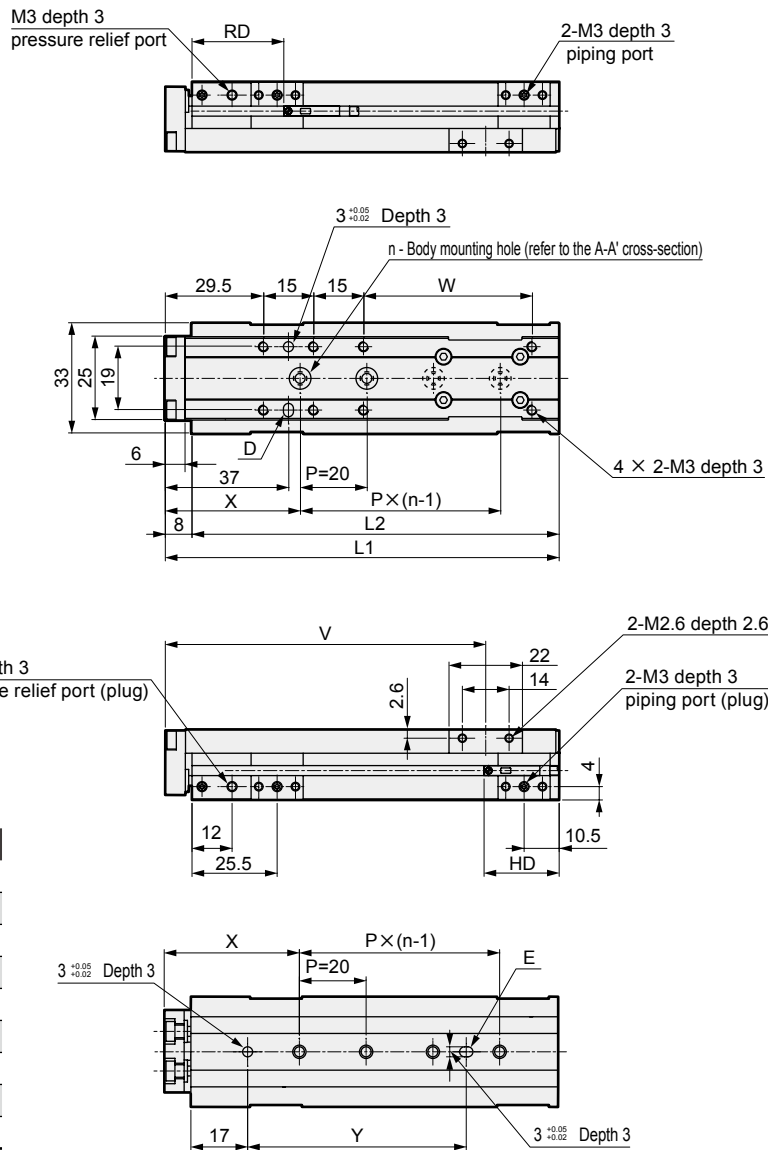

Dimensions by stroke length

Stroke length	40	50
L1	108	118
L2	100	110
n	3	4
V	86	96
W	40.5	50.5
X	39	40.5
Y	44	65.5
RD	27	
HD	33	

● Dimensions of protruding section when the F2S or F3S cylinder switch is mounted

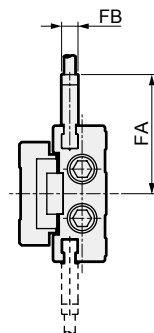

Stroke length	40	50
FA	29.1	
FB	4	
RD	26	
HD	34	

*1: When using a positioning hole, use a pin of dimensions that do not require press fitting. The recommended tolerance of a pin is JIS tolerance m6 or less.

LCW
LCR
LCG
LCX
LCM
STM
STG
STS/STL
STR2
UCA2
ULK*
JSK/M2
JSG
JSC3/JSC4
USSD
UFCD
USC
JSB3
LMB
LML
HCM
HCA
LBC
CAC4
UCAC2
CAC-N
UCAC-N
RCC2
RCS
PCC
SHC
MCP
GLC
MFC
BBS
RRC
GRC
RV3*
NHS
HR
LN
Hand
Chuk
MecHnd/Chuk
ShkAbs
FJ
FK
SpdContr
Ending

LCR-P7* Series

Dimensions (bore size: $\phi 8$)



● LCR-8-P7*

Stroke length: 10, 20, 30
(Body mounting hole in the figure shows 30 mm stroke length)

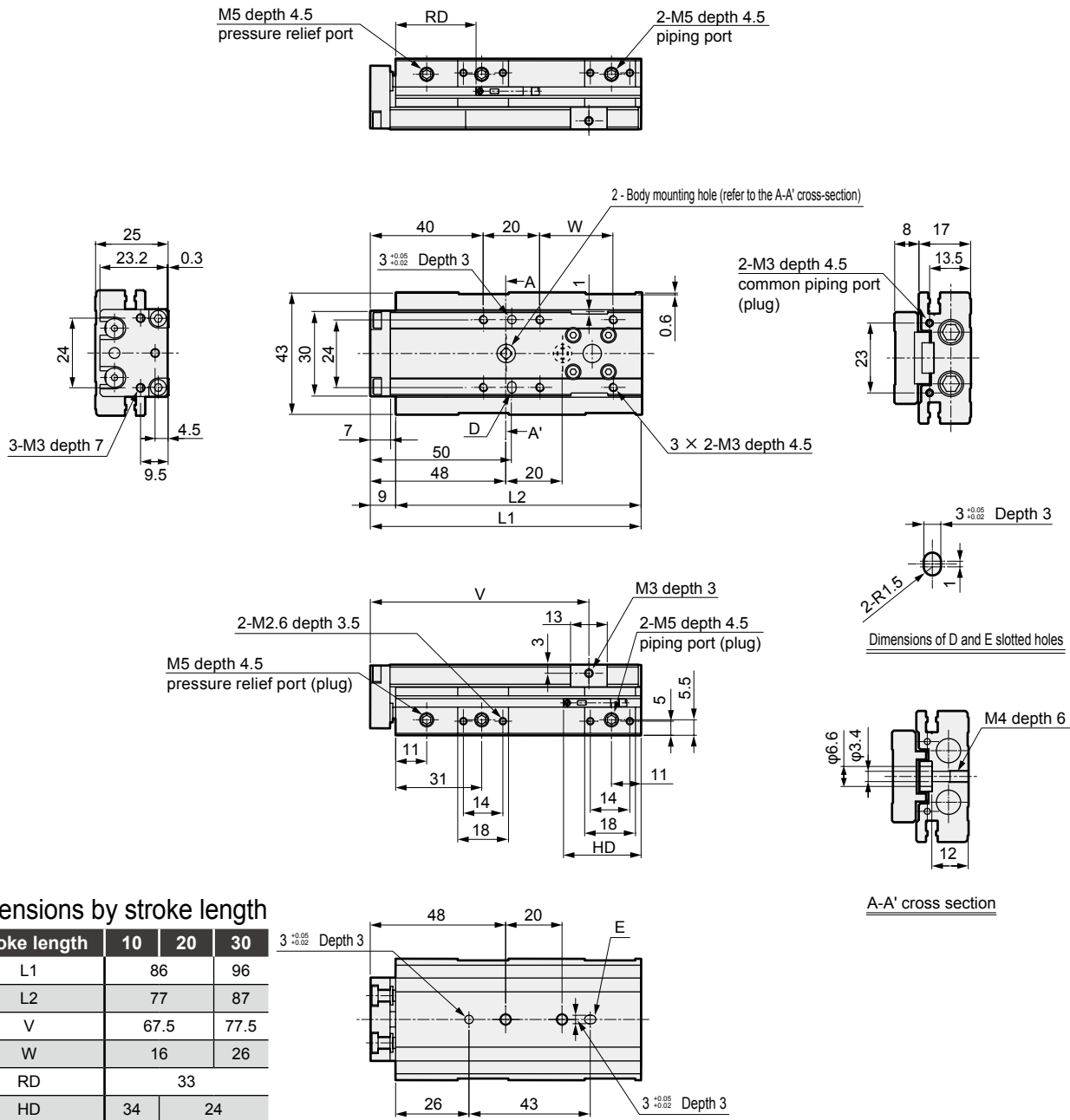

Dimensions by stroke length

Stroke length	10	20	30
L1	86	96	
L2	77	87	
V	67.5	77.5	
W	16	26	
RD	33		
HD	34	24	

● Dimensions of protruding section when the F2S or F3S cylinder switch is mounted

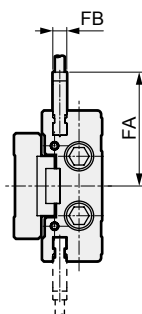

Stroke length	10	20	30
FA	32.6		
FB	4		
RD	32		
HD	35	25	

- *1 : When using a positioning hole, use a pin of dimensions that do not require press fitting. The recommended tolerance of a pin is JIS tolerance m6 or less.
- *2 : When using rear piping, refer to the cautions of 1. Common; when piping on page 133.

Dimensions (bore size: $\phi 8$)



● LCR-8-P7*

Stroke length: 40, 50, 75

(Body mounting hole in the figure shows 50 mm stroke length)

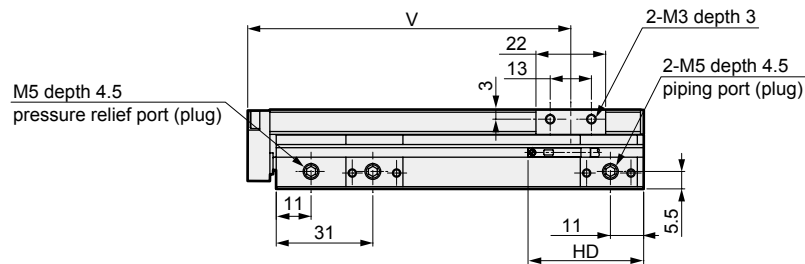
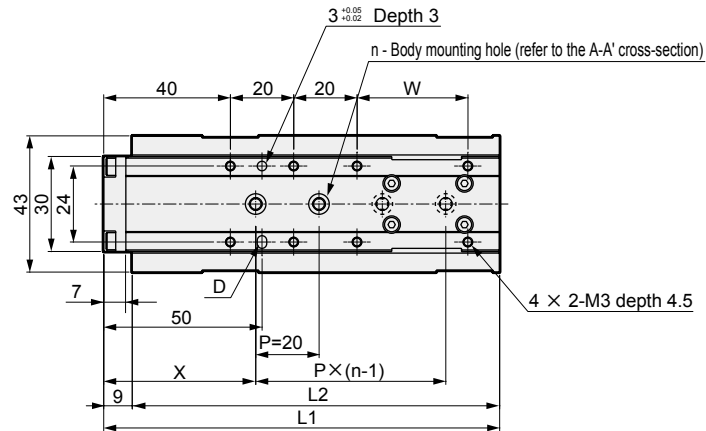

Dimensions by stroke length

Stroke length	40	50	75
L1	115	125	150
L2	106	116	141
n	3	4	5
V	92	102	127
W	25	35	60
X	46.5	48	45
Y	41.5	63	80
RD	33		
HD	33		

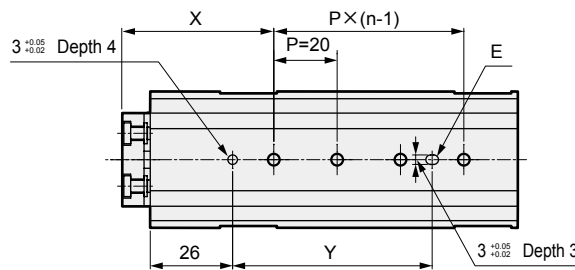

● Dimensions of protruding section when the F2S or F3S cylinder switch is mounted

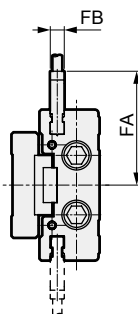

Stroke length	40	50	75
FA	32.6		
FB	4		
RD	32		
HD	34		

*1 : When using a positioning hole, use a pin of dimensions that do not require press fitting. The recommended tolerance of a pin is JIS tolerance m6 or less.

*2 : When using rear piping, refer to the cautions of [1. Common; when piping](#) on page 133.

LCW
LCR
LCG
LCX
LCM
STM
STG
STS/STL
STR2
UCA2
ULK*
JSK/M2
JSG
JSC3/JSC4
USSD
UFCD
USC
JSB3
LMB
LML
HCM
HCA
LBC
CAC4
UCAC2
CAC-N
UCAC-N
RCC2
RCS
PCC
SHC
MCP
GLC
MFC
BBS
RRC
GRC
RV3*
NHS
HR
LN
Hand
Chuk
MecHnd/Chuk
ShkAbs
FJ
FK
SpdContr
Ending

Dimensions (bore size: φ12)



● LCR-12-P7*

Stroke length: 75, 100

(Body mounting hole in the figure shows 75 mm stroke length)

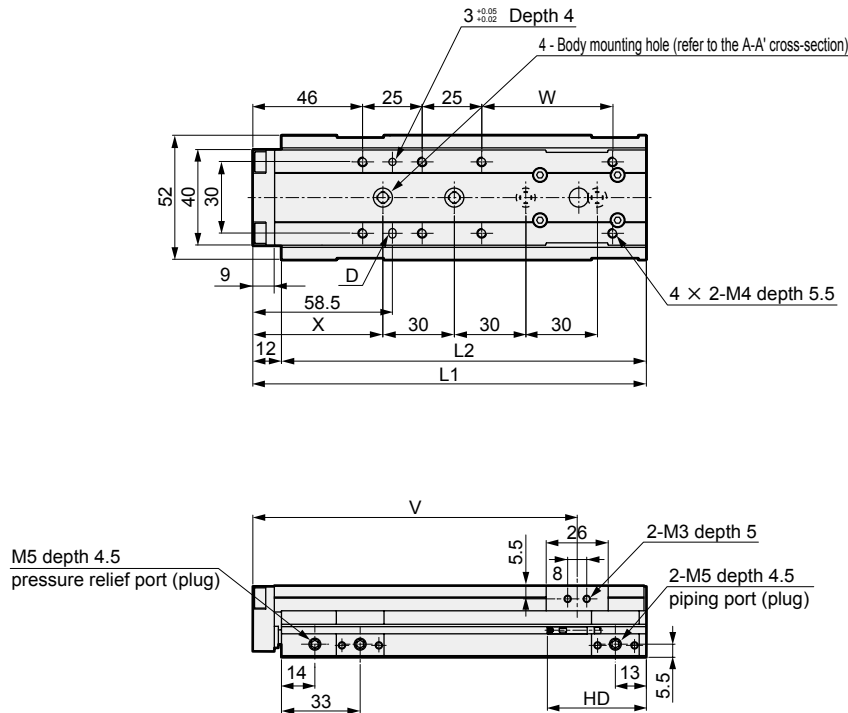

Dimensions by stroke length

Stroke length	75	100
L1	165	190
L2	153	178
V	136	161
W	55	80
X	54.5	67
Y	89.5	102
RD	36.5	
HD	41.5	

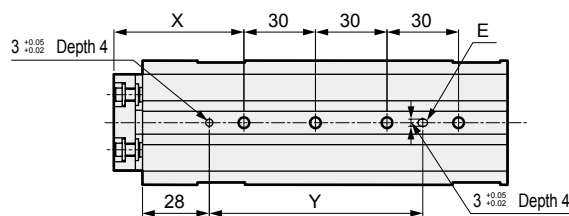

● Dimensions of protruding section when the F2S or F3S cylinder switch is mounted

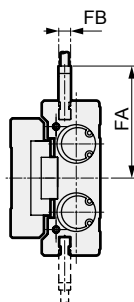

Stroke length	75	100
FA	37.8	
FB	4	
RD	35.5	
HD	42.5	

*1 : When using a positioning hole, use a pin of dimensions that do not require press fitting. The recommended tolerance of a pin is JIS tolerance m6 or less.

*2 : When using rear piping, refer to the cautions of

1. Common; when piping on page 133.

LCW
LCR
LCG
LCX
LCM
STM
STG
STS/STL
STR2
UCA2
ULK*
JSK/M2
JSG
JSC3/JSC4
USSD
UFCD
USC
JSB3
LMB
LML
HCM
HCA
LBC
CAC4
UCAC2
CAC-N
UCAC-N
RCC2
RCS
PCC
SHC
MCP
GLC
MFC
BBS
RRC
GRC
RV3*
NHS
HR
LN
Hand
Chuk
MecHnd/Chuk
ShkAbs
FJ
FK
SpdContr
Ending

Dimensions (bore size: $\phi 16$)



● LCR-16-P7*

Stroke length: 75, 100, 125

(Body mounting hole in the figure shows 75 mm stroke length)

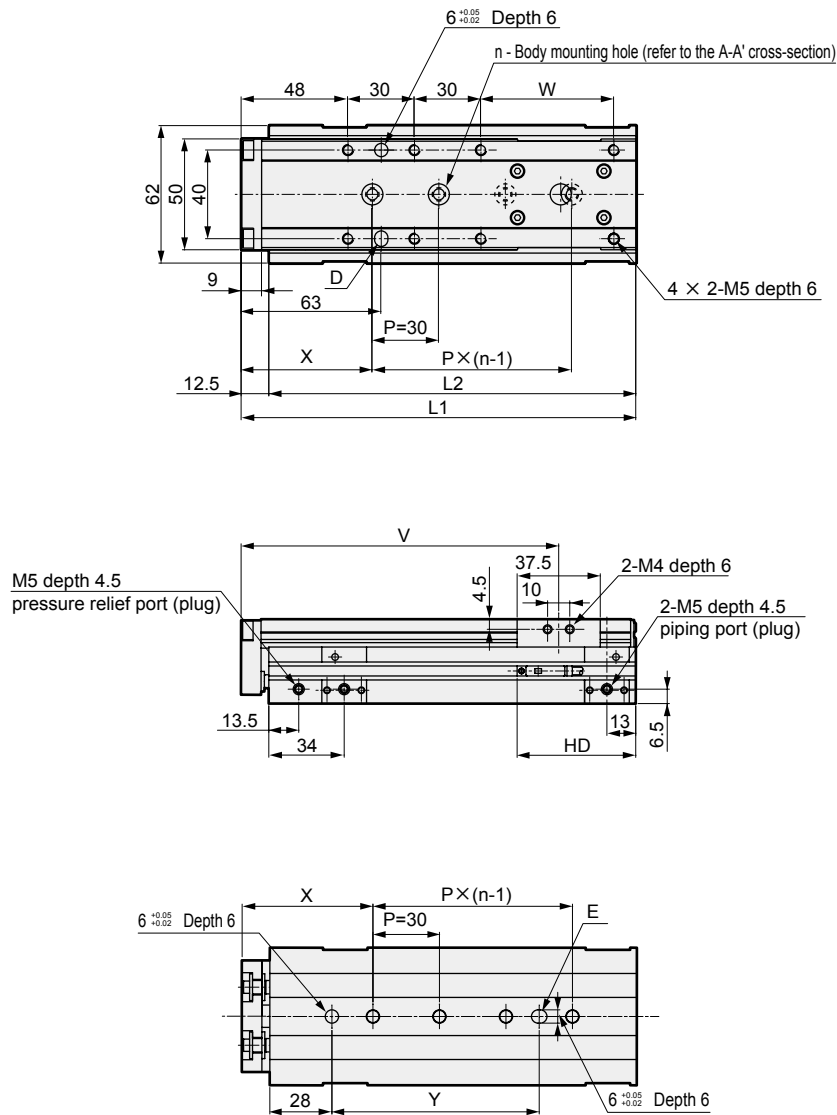

Dimensions by stroke length

Stroke length	75	100	125
L1	178	203	228
L2	165.5	190.5	215.5
n	4	5	
V	143.3	168.3	193.3
W	60	85	110
X	59	57	69
Y	93.5	121.5	133.5
T0/5*	RD	37	
T2/3*	HD	53.5	
T2/3W*	RD	39.5	
	HD	51	

*1 : When using a positioning hole, use a pin of dimensions that do not require press fitting. The recommended tolerance of a pin is JIS tolerance m6 or less.

*2 : When using rear piping, refer to the cautions of [1. Common; when piping](#) on page 133.

LCW
LCR
LCG
LCX
LCM
STM
STG
STS/STL
STR2
UCA2
ULK*
JSK/M2
JSG
JSC3/JSC4
USSD
UFCD
USC
JSB3
LMB
LML
HCM
HCA
LBC
CAC4
UCAC2
CAC-N
UCAC-N
RCC2
RCS
PCC
SHC
MCP
GLC
MFC
BBS
RRC
GRC
RV3*
NHS
HR
LN
Hand
Chuk
MecHnd/Chuk
ShkAbs
FJ
FK
SpdContr
Ending

LCR-P7* Series

Dimensions (bore size: $\phi 20$)



● LCR-20-P7*

Stroke: 10, 20, 30, 40, 50

(Body mounting hole in the figure shows 30 mm stroke length)

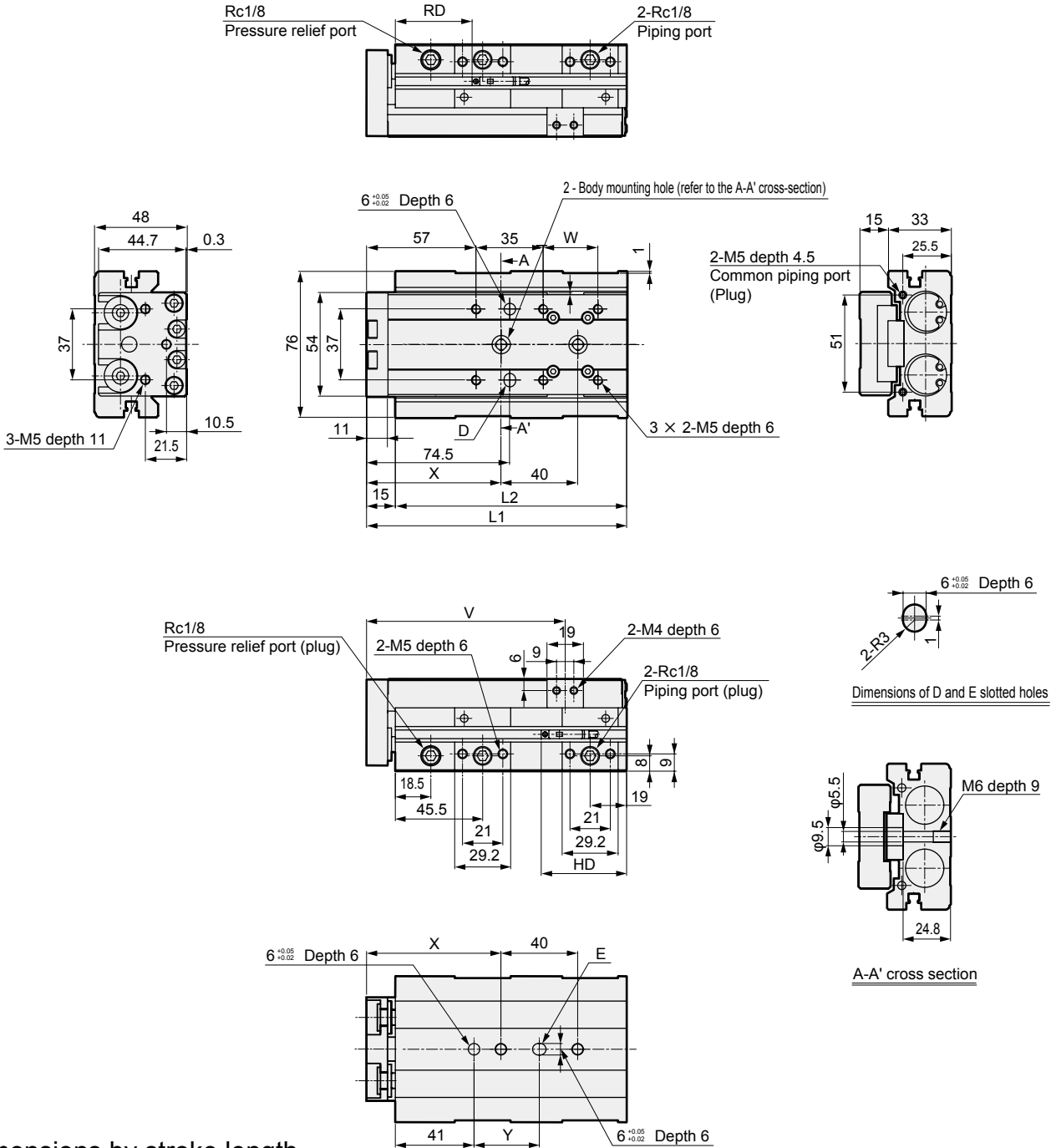

Dimensions by stroke length

Stroke length	10	20	30	40	50
L1		135.5	145.5	155.5	
L2		120.5	130.5	140.5	
V		103.5	113.5	123.5	
W		28.5	38.5	48.5	
X		70	76	74	
Y		34	40	38	
T0/5*	RD	45.5			
T2/3*	HD	65	55	45	
T2/3W*	RD	47			
	HD	63	53	43	

*1 : When using a positioning hole, use a pin of dimensions that do not require press fitting. The recommended tolerance of a pin is JIS tolerance m6 or less.

*2 : When using rear piping, refer to the cautions of 1. Common; when piping on page 133.

Dimensions (bore size: $\phi 20$)



● LCR-20-P7*

Stroke length: 75, 100, 125, 150

(Body mounting hole in the figure shows 100 mm stroke length)

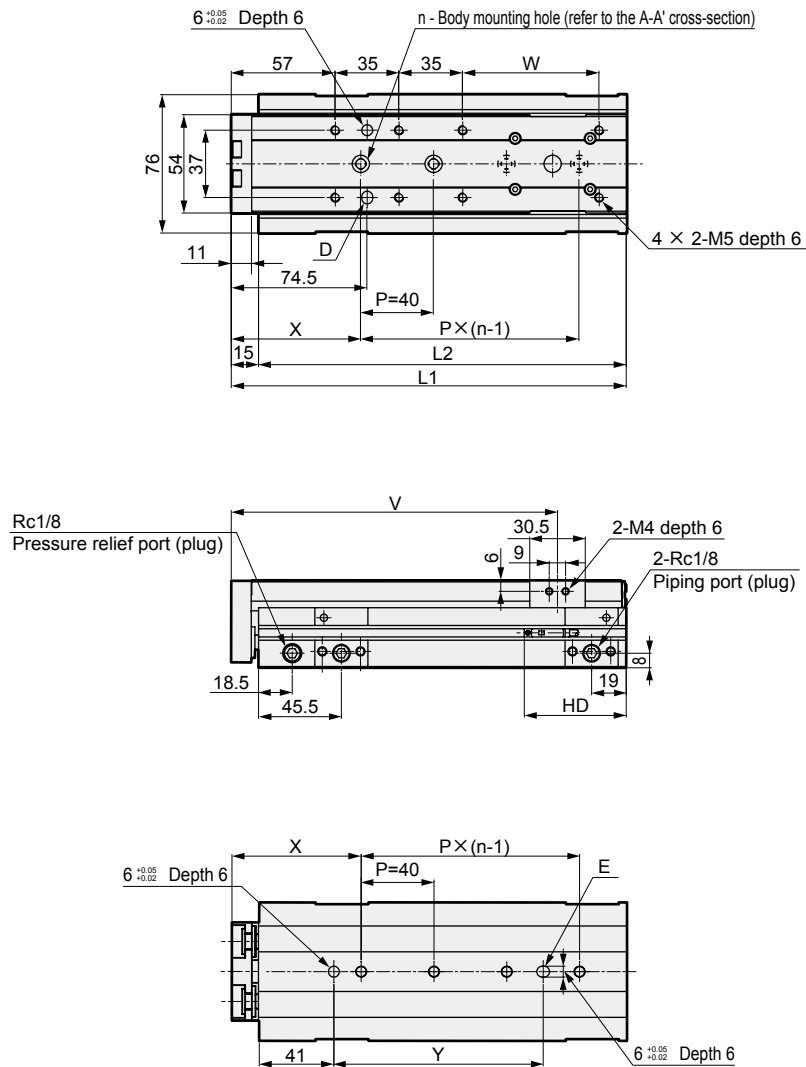

Dimensions by stroke length

Stroke length	75	100	125	150
L1	192	217	242	267
L2	177	202	227	252
n	3	4	5	
V	154.3	179.3	204.3	229.3
W	50	75	100	125
X	71		78	76
Y	75	115	122	160
T0/5*	RD	45.5		
T2/3*	HD	57.5		
T2/3W*	RD	47		
	HD	55.5		

*1 : When using a positioning hole, use a pin of dimensions that do not require press fitting. The recommended tolerance of a pin is JIS tolerance m6 or less.

*2 : When using rear piping, refer to the cautions of [1. Common; when piping](#) on page 133.

LCW
LCR
LCG
LCX
LCM
STM
STG
STS/STL
STR2
UCA2
ULK*
JSK/M2
JSG
JSC3/JSC4
USSD
UFCD
USC
JSB3
LMB
LML
HCM
HCA
LBC
CAC4
UCAC2
CAC-N
UCAC-N
RCC2
RCS
PCC
SHC
MCP
GLC
MFC
BBS
RRC
GRC
RV3*
NHS
HR
LN
Hand
Chuk
MecHnd/Chuk
ShkAbs
FJ
FK
SpdContr
Ending

LCR-P7* Series

Dimensions (bore size: $\phi 25$)



● LCR-25-P7*

Stroke: 10, 20, 30, 40, 50

(Body mounting hole in the figure shows 30 mm stroke length)

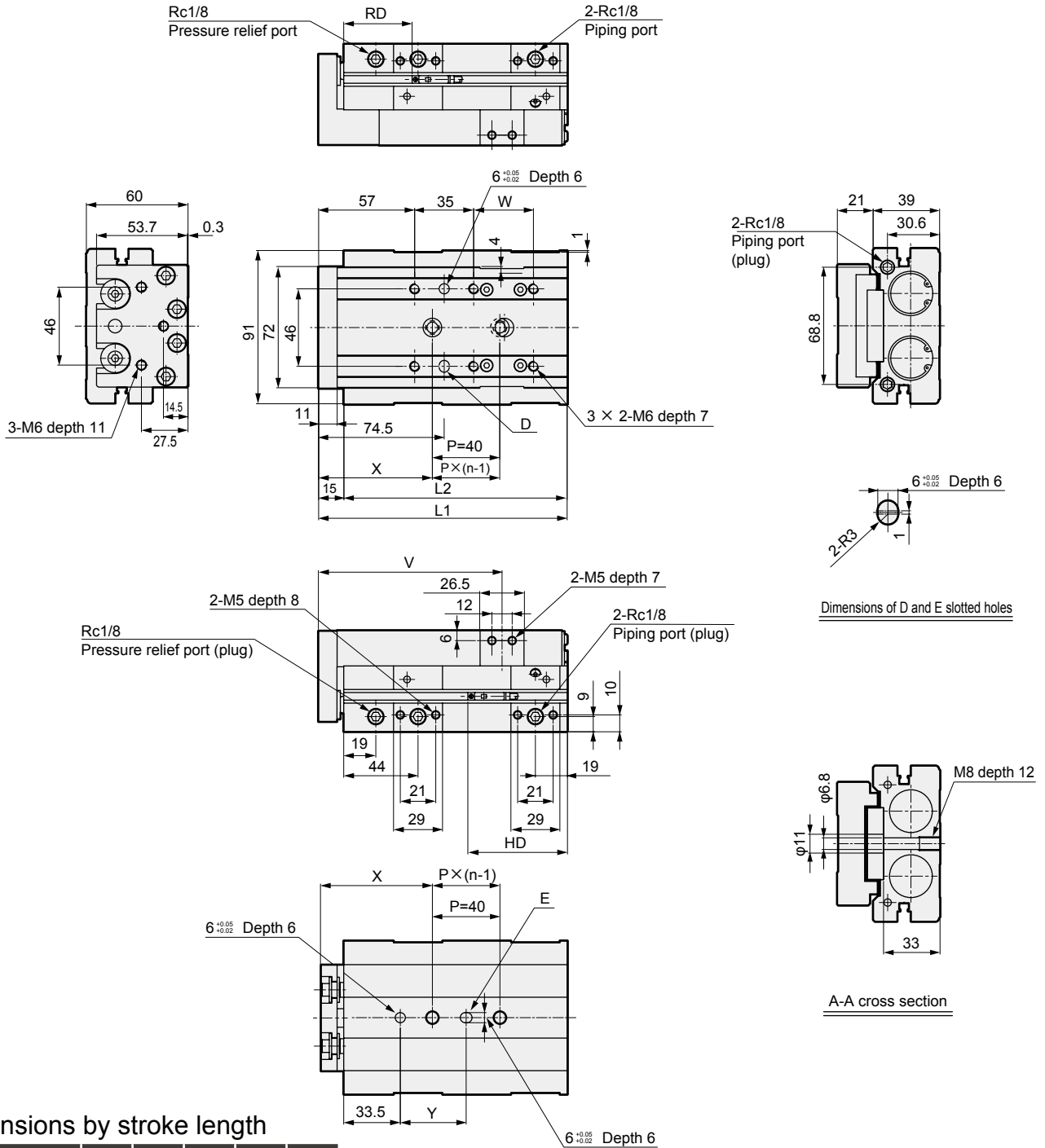

Dimensions by stroke length

Stroke length	10	20	30	40	50
L1		147.5	157.5	167.5	
L2		132.5	142.5	152.5	
n		2	3	2	
V		108.8	118.8	128.8	
W		35.5	45.5	55.5	
X		67.5	70.5	85.5	
Y		39	42	57	
T0/5*	RD	44			
T2/3*	HD	78.5	68.5	58.5	
T2/3W*	RD	46			
	HD	76.5	66.5	56.5	

*1 : When using a positioning hole, use a pin of dimensions that do not require press fitting. The recommended tolerance of a pin is JIS tolerance m6 or less.

*2 : When using rear piping, refer to the cautions of 1. Common; when piping on page 133.

Dimensions (bore size: $\phi 25$)



● LCR-25-P7*

Stroke length: 75, 100, 125, 150

(Body mounting hole in the figure shows 100 mm stroke length)

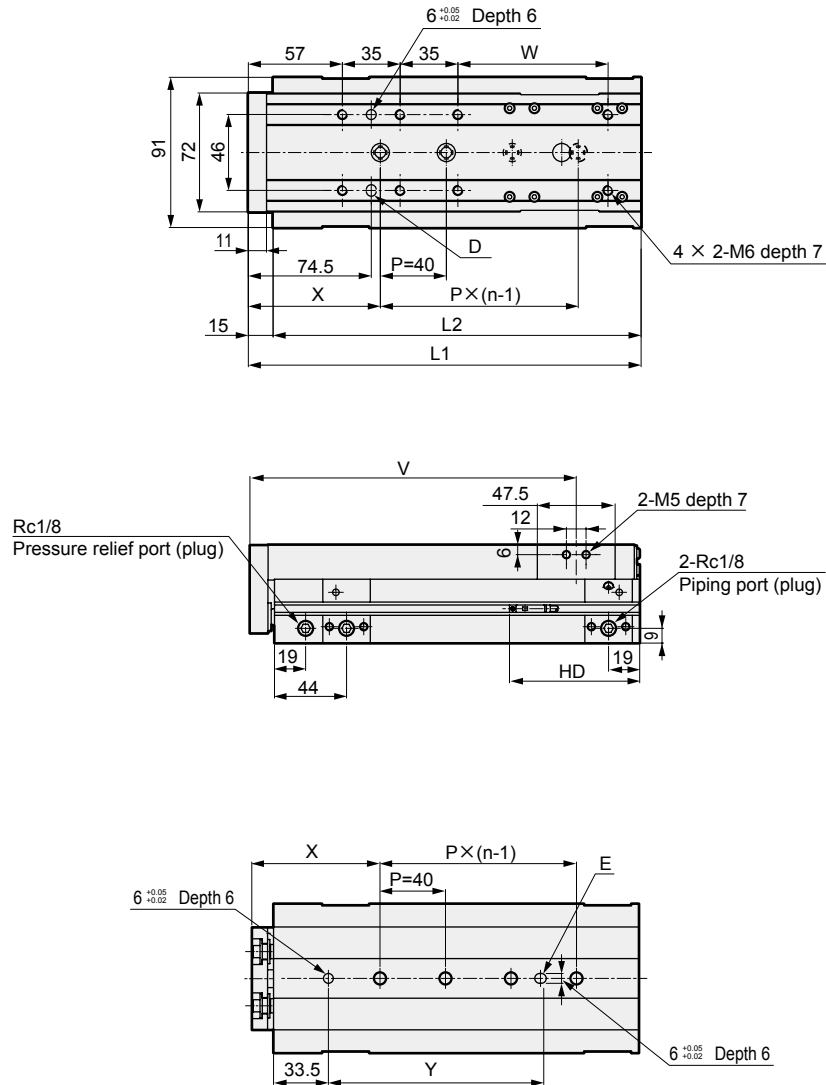

Dimensions by stroke length

Stroke length	75	100	125	150
L1	213	238	263	288
L2	198	223	248	273
n	3	4	5	
V	163.8	188.8	213.8	238.8
W	66	91	116	141
X	85	80	70	85
Y	96.5	131.5	161.5	176.5
T0/5*	RD	44		
T2/3*	HD	79		
T2/3W*	RD	46		
	HD	77		

*1 : When using a positioning hole, use a pin of dimensions that do not require press fitting. The recommended tolerance of a pin is JIS tolerance m6 or less.

*2 : When using rear piping, refer to the cautions of

1. Common; when piping on page 133.

LCW
LCR
LCG
LCX
LCM
STM
STG
STS/STL
STR2
UCA2
ULK*
JSK/M2
JSG
JSC3/JSC4
USSD
UFCD
USC
JSB3
LMB
LML
HCM
HCA
LBC
CAC4
UCAC2
CAC-N
UCAC-N
RCC2
RCS
PCC
SHC
MCP
GLC
MFC
BBS
RRC
GRC
RV3*
NHS
HR
LN
Hand
Chuk
MecHnd/Chuk
ShkAbs
FJ
FK
SpdContr
Ending

LCR-P7* Series

Dimensions: Option

● Stroke adjusting stopper (S1 to S6)

· For $\phi 8$

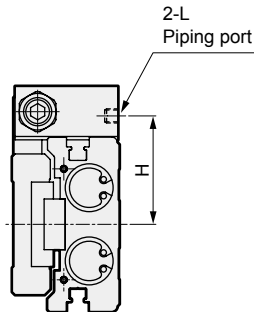
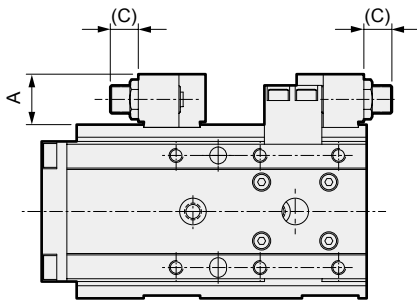
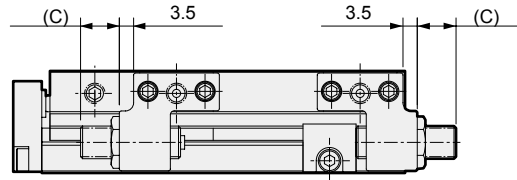
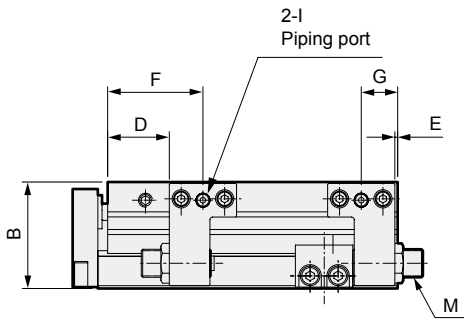

*1: F, G, H, I and L dimensions are only for the types with port on the stopper (S*D*).

Code	Bore size (mm)	A	B	C			D	E	F	G	H	I	L	M
				Adjustable stroke range										
				5 mm	15 mm	25 mm								
$\phi 6$	14	19.5	11	21	-	16	1	25.5	10.5	24	M3 depth 3	M3 depth 3	M8×0.75	
$\phi 8$	15.6	24.5	9.5	19.5	-	20.5	0.5	30.5	10.5	27.3	M5 depth 4	M5 depth 4	M8×0.75	
$\phi 12$	15.5	29	12	22	32	21	1	33	13	31	M5 depth 4	M5 depth 4	M8×0.75	
$\phi 16$	18	37	10	20	30	22	1	34	13	39	M5 depth 4	M5 depth 4	M10×1	
$\phi 20$	20.5	45	14.5	24.5	34.5	29	2.5	45.5	19	46	Rc1/8	M5 depth 4	M12×1	
$\phi 25$	20.5	57	11.5	21.5	31.5	27.5	2.5	44	19	54.5	Rc1/8	M5 depth 4	M12×1	

LCW
LCR
LCG
LCX
LCM
STM
STG
STS/STL
STR2
UCA2
ULK*
JSK/M2
JSG
JSC3/JSC4
USSD
UFCD
USC
JSB3
LMB
LML
HCM
HCA
LBC
CAC4
UCAC2
CAC-N
UCAC-N
RCC2
RCS
PCC
SHC
MCP
GLC
MFC
BBS
RRC
GRC
RV3*
NHS
HR
LN
Hand
Chuk
MecHnd/Chuk
ShkAbs
FJ
FK
SpdContr
Ending

MEMO

LCW
LCR
LCG
LCX
LCM
STM
STG
STS/STL
STR2
UCA2
ULK*
JSK/M2
JSG
JSC3/JSC4
USSD
UFCD
USC
JSB3
LMB
LML
HCM
HCA
LBC
CAC4
UCAC2
CAC-N
UCAC-N
RCC2
RCS
PCC
SHC
MCP
GLC
MFC
BBS
RRC
GRC
RV3*
NHS
HR
LN
Hand
Chuk
MecHnd/Chuk
ShkAbs
FJ
FK
SpdContr
Ending

LCW
LCR
 LCG
 LCX
 LCM
 STM
 STG
 STS/STL
 STR2
 UCA2
 ULK*
 JSK/M2
 JSG
 JSC3/JSC4
 USSD
 UFCD
 USC
 JSB3
 LMB
 LML
 HCM
 HCA
 LBC
 CAC4
 UCAC2
 CAC-N
 UCAC-N
 RCC2
 RCS
 PCC
 SHC
 MCP
 GLC
 MFC
 BBS
 RRC
 GRC
 RV3*
 NHS
 HR
 LN
 Hand
 Chuk
 MecHnd/Chuk
 ShkAbs
 FJ
 FK
 SpdContr
 Ending

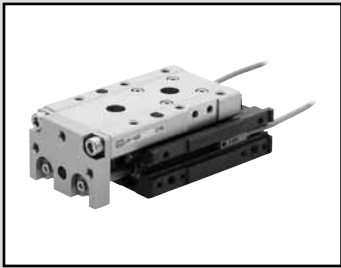

Linear slide cylinder Double acting/fine speed

LCR-F Series

● Bore size: $\phi 12/\phi 16/\phi 20/\phi 25$

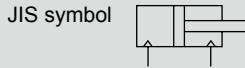

Specifications

Descriptions		LCR-F			
Bore size	mm	$\phi 12$	$\phi 16$	$\phi 20$	$\phi 25$
Actuation		Double acting			
Working fluid		Compressed air			
Max. working pressure	MPa	0.7 (≈ 100 psi, 7 bar)			
Min. working pressure	MPa	0.15 (≈ 22 psi, 1.5 bar)			
Proof pressure	MPa	1.05 (≈ 150 psi, 10.5 bar)			
Ambient temperature	$^{\circ}\text{C}$	5 (41°F) to 60 (140°F)			
Port size	Main body side	M5		Rc1/8	
	Main body back	M3	M5	Rc1/8	
Stroke tolerance	mm	+2.0 0 (*1)			
Working piston speed	mm/s	5 to 200 (no load at 0.5 MPa (≈ 73 psi, 5 bar))			
Cushion		With rubber cushion			
Lubrication		Not available			
Allowable absorbed energy	J	Refer to Table 3 on page 124.			

*1: Note that there will be a slight gap between the end plate and floating bush if no stopper is attached.

*2: Contact CKD for $\phi 6$ and $\phi 8$.

*3: The stroke adjusting stopper for 0.3 MPa and over working pressure is the metal sealing.

Stroke length

Bore size (mm)	Standard stroke length (mm)
$\phi 12$	10, 20, 30, 40, 50, 75, 100
$\phi 16$	10, 20, 30, 40, 50, 75, 100, 125
$\phi 20$	10, 20, 30, 40, 50, 75, 100, 125, 150
$\phi 25$	10, 20, 30, 40, 50, 75, 100, 125, 150

Note: Products with stroke lengths other than the above are not available.

Theoretical thrust table

Refer to page 125.

Low speed performance

The following data is at no load and supply pressure 0.5 MPa. As the values vary with measurement conditions, etc., they are not guaranteed.

● LCR-12-30

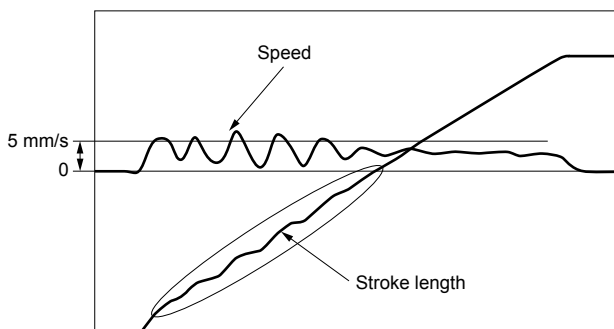

Stick-slip occurs during the stroke when a speed of 5 mm/s is set.

● LCR-F-12-30

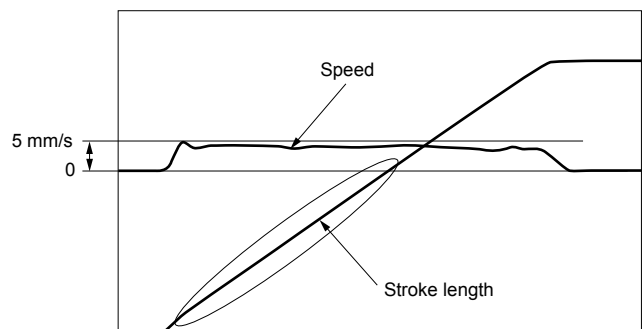

With the basic, stick-slip occurs at a speed of 5 mm/s, whereas the fine speed can be stably operated without stick-slip.

Switch specifications

- 1-color/2-color display

Descriptions	Reed 2-wire				Proximity 2-wire		Proximity 3-wire		
	T0H/T0V		T5H/T5V		T2H/T2V	T2WH/T2WV	T3H/T3V	T3PH/T3PV (custom)	T3WH/T3WV
Applications	For programmable controller, relay		For programmable controller, relay, IC circuit (without indicator lamp), serial connection		Dedicated for programmable controller		For programmable controller, relay		
Output method	-		-		-		NPN output	PNP output	NPN output
Power supply voltage	-		-		-		10 to 28 VDC		
Load voltage	12/24 VDC	110 VAC	5/12/24 VDC	110 VAC	10 to 30 VDC	24 VDC ±10%	30 VDC or less		
Load current	5 to 50 mA	7 to 20 mA	50 mA or less	20 mA or less	5 to 20 mA		100 mA or less	50 mA or less	
Indicator lamp	LED (Lit when ON)		Without indicator lamp		LED (Lit when ON)	Red/green LED (Lit when ON)	LED (Lit when ON)	Yellow LED (Lit when ON)	Red/green LED (Lit when ON)
Leakage current	0 mA				1 mA or less		10 µA or less		
Weight	g		1 m:18 3 m:49 5 m:80						

Descriptions	Proximity 2-wire		Proximity 3-wire		Proximity 2-wire		Proximity 3-wire		
	F2S		F3S		F2H/F2V	F2YH/F2YV	F3H/F3V	F3PH/F3PV (Custom order)	F3YH/F3YV
Applications	Dedicated for programmable controller		For programmable controller, relay		Dedicated for programmable controller		For programmable controller, relay		
Output method	-		NPN output		-		NPN output	PNP output	NPN output
Power supply voltage	-		10 to 28 VDC		-		10 to 28 VDC	4.5 to 28 VDC	10 to 28 VDC
Load voltage	10 to 30 VDC		30 VDC or less		10 to 30 VDC	24 VDC ±10%	30 VDC or less		
Load current	5 to 20 mA		50 mA or less		5 to 20 mA		100 mA or less	50 mA or less	
Indicator lamp	LED (Lit when ON)		LED (Lit when ON)		Yellow LED (Lit when ON)	Red/green LED (Lit when ON)	Yellow LED (Lit when ON)		Red/green LED (Lit when ON)
Leakage current	1 mA or less		10 µA or less		1 mA or less		10 µA or less		
Weight	g		1 m:10 3 m:29						

*1 : The T0/T5 switch can also be used with 220 VAC. Contact CKD about working conditions.

*2 : Refer to Ending Page 1 for other switch specifications.

*3 : Dimensions depend on switch model No. Refer to Ending Pages 18 and 23 for details.

Cylinder weight

- Fine speed

(Unit: g)

Bore size (mm)	Basic Stroke length (mm)								
	10	20	30	40	50	75	100	125	150
φ12	310	320	320	360	390	520	610	-	-
φ16	490	500	500	550	610	840	970	1,110	-
φ20	900	910	920	1,000	1,090	1,390	1,600	1,810	2,020
φ25	1,620	1,640	1,650	1,760	1,860	2,350	2,620	2,890	3,160

- Additional weight of options

(Unit: g)

Bore size (mm)	Option/stopper code			
	S1 to S4	S5/S6	A1 to A4	A5/A6
φ12	70	100	80	110
φ16	110	150	120	160
φ20	170	250	180	270
φ25	290	380	300	400

Specifications for rechargeable battery (Catalog No. CC-1226A)

LCR - ... - **P4*** ● Design compatible with rechargeable battery manufacturing process.

* Contact CKD for details.

Dimensions

Same as double acting/single rod. Refer to pages 76 to 84.

LCW
LCR
LCG
LCX
LCM
STM
STG
STS/STL
STR2
UCA2
ULK*
JSK/M2
JSG
JSC3/JSC4
USSD
UFCD
USC
JSB3
LMB
LML
HCM
HCA
LBC
CAC4
UCAC2
CAC-N
UCAC-N
RCC2
RCS
PCC
SHC
MCP
GLC
MFC
BBS
RRC
GRC
RV3*
NHS
HR
LN
Hand
Chuk
MecHnd/Chuk
ShkAbs
FJ
FK
SpdContr
Ending

LCR-F Series

How to order

Without switch (built-in magnet for switch)

LCR-F - 12 - 40 - S506 DTN

With switch (built-in magnet for switch)

LCR-F - 12 - 40 - F2H* - R - S506 DTN

Model No. A Bore size D Switch quantity F Option

B Stroke length

C Switch model No.

⚠ Precautions for model No. selection

- *1 : For the adjustable stroke range with a shock absorber stopper, refer to the stopper dimensions table on page 84.
- *2 : For the port position, refer to the stopper dimensions on page 84.
- *3 : The port positions of the standard without stopper are ① and ③ in the figure below.
- *4 : Combination of the stroke adjusting stopper and shock absorber stopper is custom order.
- *5 : Can be selected for the type with stopper only.
- *6 : Refer to the selection table on page 119 for combinations of options.
- *7 : A1**, A2**, A5** and A6** of $\phi 12$ to $\phi 25$ with 20 mm stroke length or less are custom order, since adjustment is not possible with the standard stopper.
- *8 : Select when using rear piping.
- *9 : Can be selected only when using stroke adjusting stopper (S) and one side mixed type (C).
- *10 : When two switches are necessary or a switch is installed on the head side of W3 to 6 (two-sided concurrently-used double stopper) of $\phi 12$ with 30 mm stroke length or $\phi 16$ with 30 mm stroke length, select the axial lead wire.
- *11 : Cannot be selected with the two-sided combined (W).
- *12 : The adjustable stroke range with the two-sided combined (W) is $\phi 12$: 14.5 mm, $\phi 16$: 15 mm, $\phi 20$: 13 mm, $\phi 25$: 10 mm.
- *13 : The stroke adjusting stopper for 0.3 MPa and over working pressure is the metal sealing.

[Example of model No.]

LCR-F-12-40-F2H-R-A1DT

Model: Linear slide cylinder Double acting/fine speed LCR-F

- A Bore size : $\phi 12$
- B Stroke length : 40 mm
- C Switch model No. : Proximity/2-wire Axial lead wire
- D Switch quantity : 1 on rod side
- E Stopper : Shock absorber Stopper position ①
- F Option : With side and bottom ports Material, steel (nitriding)

E Stopper

● Stopper position

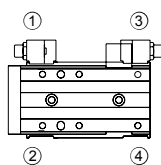

Code	Content
A Bore size	
12	$\phi 12$
16	$\phi 16$
20	$\phi 20$
25	$\phi 25$

B Stroke length (mm)		Bore size (ϕ)			
		12	16	20	25
10	10	●	●	●	●
20	20	●	●	●	●
30	30	●	●	●	●
40	40	●	●	●	●
50	50	●	●	●	●
75	75	●	●	●	●
100	100	●	●	●	●
125	125		●	●	●
150	150			●	●

C Switch model No.		Bore size							
Axial lead wire	Radial lead wire	Contact	Voltage AC DC	Indicator lamp	Lead wire	$\phi 12$	$\phi 16$	$\phi 20$	$\phi 25$
F2S*		Proximity	●	1-color display	2-wire				
F3S*			●		3-wire				
F2H*	F2V*		●		2-wire				
F3H*	F3V*		●		3-wire	●			
F3PH*	F3PV*	Proximity	●	1 color display (PNP output) (custom)	3-wire				
F2YH*	F2YV*		●	2-color display	2-wire				
F3YH*	F3YV*		●	no indicator lamp	3-wire				
T0H*	T0V*	Reed	●	1-color display	2-wire				
T5H*	T5V*		●		3-wire				
T2H*	T2V*		●	1-color display	2-wire				
T3H*	T3V*	Proximity	●	1-color display	3-wire				
T3PH*	T3PV*		●	1-color display (PNP output) (custom)	3-wire	●	●	●	
T2WH*	T2WV*		●	2-color display	2-wire				
T3WH*	T3WV*		●		3-wire				

* Lead wire length

Blank	1 m (standard)		●
3	3 m (option)		●
5	5 m (option)		●

D Switch quantity

R	1 on rod side
H	1 on head side
D	2

E Stopper

Refer to "Stopper" on page 117.

F Option

Blank	Port on the stopper: without port
D	Port on stopper: side and bottom ports *2, *5, *11
Blank	Stopper block material: steel
T	Stopper block material: steel (nitriding) *5
Plug attached	
Blank	None
N	With side piping port plug (not available for $\phi 25$) *8

[E] Stopper

Code	Content	Code	Content
E Stopper			
Blank	No option	C One side hybrid stopper mix (shock absorber stopper, stroke adjusting stopper)	
S Stroke adjusting stopper *4/*7		C1**	A1+S3
S1**	Stopper position ① (can be changed to ④)	C2**	A2+S4
S2**	Stopper position ② (can be changed to ③)	C3**	A3+S1
S3**	Stopper position ③ (can be changed to ②) *14	C4**	A4+S2
S4**	Stopper position ④ (can be changed to ①) *14	** part Adjustable stroke range ● Compatible with all. ▲ Compatible with some. *9	
S5**	Stopper position ①, ③		
S6**	Stopper position ②, ④		
A Shock absorber stopper *1/*4/*7		Blank	5 mm or none
A1	Stopper position ① (can be changed to ④)	02	15 mm or none
A2	Stopper position ② (can be changed to ③)	03	25 mm or none
A3	Stopper position ③ (can be changed to ②) *14	04	15 mm
A4	Stopper position ④ (can be changed to ①) *14	05	25 mm
A5	Stopper position ①, ③	06	5 mm
A6	Stopper position ②, ④	07	5 mm
W Two-sided combined double stopper (shock absorber stopper, metal stopper) *4/*7		*14: When changing the stopper position from the head side to the rod side, the stopper must be purchased separately according to the stroke length and adjustable stroke length. Refer to "Precautions when purchasing discrete stopper" on page 67. A1, A2 and adjustable stroke length of 15 mm and 25 mm may not be available depending on the stroke length.	
W1	A1 + metal stopper		
W2	A2 + metal stopper		
W3	A3 + metal stopper		
W4	A4 + metal stopper		
W5	A5 + metal stopper		
W6	A6 + metal stopper		

LCW
LCR
LCG
LCX
LCM
STM
STG
STS/STL
STR2
UCA2
ULK*
JSK/M2
JSG
JSC3/JSC4
USSD
UFCD
USC
JSB3
LMB
LML
HCM
HCA
LBC
CAC4
UCAC2
CAC-N
UCAC-N
RCC2
RCS
PCC
SHC
MCP
GLC
MFC
BBS
RRC
GRC
RV3*
NHS
HR
LN
Hand
Chuk
MecHnd/Chuk
ShkAbs
FJ
FK
SpdContr
Ending

Stopper model No. selection method

1 Stopper combination table

Model No.- [① Stopper] [② Stopper position] [③] Example) LCR-F-12-40-[S] [5] 06

	Stroke adjustable (one side)		Shock absorber (one side)		Two-sided combined double stopper		One side hybrid stopper mix		
	Stopper model No. [①]								
	[S]	[A]	[W]	[C]	[S]	[A]	[W]	[C]	
Stopper position model No. [②]	[1]	[S1]	[A1]	[W1]	[C1]	[S2]	[A2]	[W2]	[C2]
	[2]	[S3]	[A3]	[W3]	[C3]	[S4]	[A4]	[W4]	[C4]
	[3]	[S5]	[A5]	[W5]		[S6]	[A6]	[W6]	
	[4]								
	[5]								
	[6]								

▲ shows the piping direction.

If two-sided combined (W) is selected, the stopper bracket comes with piping on both sides, ▲ (piping direction) and the reverse side stopper bracket comes with a plug.

■ : Shock absorber stopper
 ■ : Stroke adjusting stopper (adjusting range 5 mm)
 ■ : Metal adjusting stopper (adjusting range 15 mm)



Stopper model No. selection method

2 Stopper combination table

Model No. - [①②Stopper][③Adjustable stroke range]

Example) LCR-F-12-40-S5 [06]



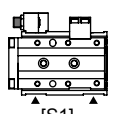
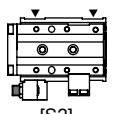
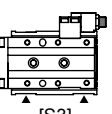
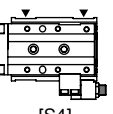
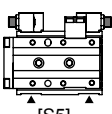
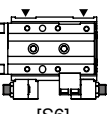
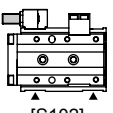
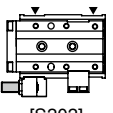
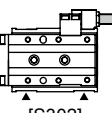
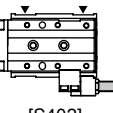
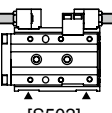
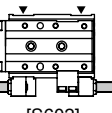
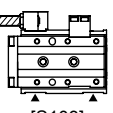
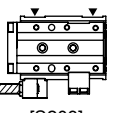
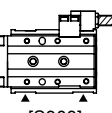
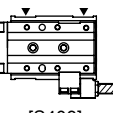
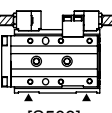
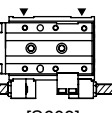
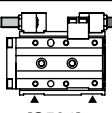
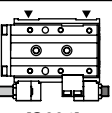
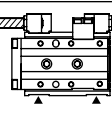
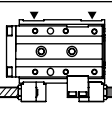
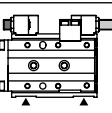
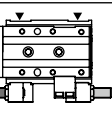
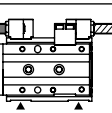
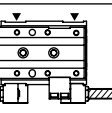

For stroke adjusting stopper -S

 : Stroke adjusting stopper (adjusting range 5 mm)
 : Stroke adjusting stopper (adjusting range 15 mm)
 : Stroke adjusting stopper (adjusting range 25 mm)

Adjustable stroke range model No. [③]	Stopper adjusting range		Stopper model No. [①②]					
	Protruding end	Return end	[S1]	[S2]	[S3]	[S4]	[S5]	[S6]
Blank	5 mm or none	5 mm or none						
[02]	15 mm or none	15 mm or none						
[03]	25 mm or none	25 mm or none						
[04]	15 mm	5 mm						
[05]	25 mm	5 mm						
[06]	5 mm	15 mm						
[07]	5 mm	25 mm						

▲ shows the piping direction.
Cannot be selected for shock absorber [A] and two-sided combined [W].

3 For one side hybrid stopper mix -C

 : Shock absorber stopper
 : Stroke adjusting stopper (adjusting range 15 mm)
 : Stroke adjusting stopper (adjusting range 5 mm)  : Stroke adjusting stopper (adjusting range 25 mm)

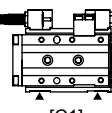
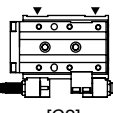
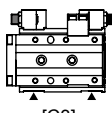
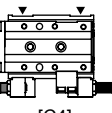
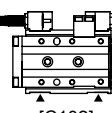
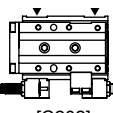
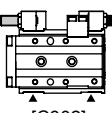
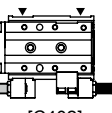
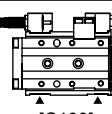
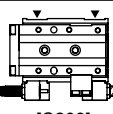
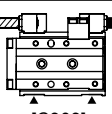
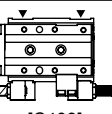
Adjustable stroke range model No. [③]	Stopper adjusting range		Stopper model No. [①②]			
	Protruding end	Return end	[C1]	[C2]	[C3]	[C4]
Blank	5 mm or shock absorber	5 mm or shock absorber				
[02]	15 mm or shock absorber	15 mm or shock absorber				
[03]	25 mm or shock absorber	25 mm or shock absorber				

▲ shows the piping direction.
For the adjustable stroke range with a shock absorber stopper, refer to the stopper dimensions table on page 84.

LCR Double acting/fine speed selection table

(Combination with stroke adjusting stopper, shock absorber stopper)

● : Available — : Not available

Model No.	Stopper		Stroke adjustable																									
	Stopper code		S1			S2			S3			S4			S5				S6									
	Bore size	Stroke mm	Adjustment length code																									
Blank			02	03	Blank	02	03	Blank	02	03	Blank	02	03	Blank	02	03	04	05	05	07	Blank	02	03	04	05	06	07	
LCR	φ12 to φ25	10	●	—	—	●	—	—	●	●	—	●	●	—	●	—	—	—	—	●	—	●	—	—	—	—	●	—
		20	●	●	—	●	●	—	●	●	●	●	●	●	●	●	—	●	—	●	●	●	●	—	●	—	●	●
		30 or more	●	●	●	●	●	●	●	●	●	●	●	●	●	●	●	●	●	●	●	●	●	●	●	●	●	●

Model No.	Stopper		Shock absorber						Two-sided combined double stopper						One side hybrid stopper mix													
	Stopper code		A1	A2	A3	A4	A5	A6	W1	W2	W3	W4	W5	W6	C1				C2			C3			C4			
	Bore size	Stroke mm													Adjustment length code													
Blank			02	03	Blank	02	03	Blank	02	03	Blank	02	03	Blank	02	03	Blank	02	03	Blank	02	03						
LCR	φ12 to φ25	10	—	—	●	●	—	—	—	—	●	●	—	—	—	—	—	—	—	—	—	—	—	—	—	—	—	—
		20	—	—	●	●	—	—	—	—	●	●	—	—	—	—	—	—	—	—	—	—	—	—	—	—	—	—
		30 or more	●	●	●	●	●	●	●	●	●	●	●	●	●	●	●	●	●	●	●	●	●	●	●	●	●	●

The table above also applies to a combination with option code D (with port on the stopper) or T (alloy steel stopper block (nitriding)).

LCW
LCR
LCG
LCX
LCM
STM
STG
STS/STL
STR2
UCA2
ULK*
JSK/M2
JSG
JSC3/JSC4
USSD
UFCD
USC
JSB3
LMB
LML
HCM
HCA
LBC
CAC4
UCAC2
CAC-N
UCAC-N
RCC2
RCS
PCC
SHC
MCP
GLC
MFC
BBS
RRC
GRC
RV3*
NHS
HR
LN
Hand
Chuk
MecHnd/Chuk
ShkAbs
FJ
FK
SpdContr
Ending

LCW
LCR
 LCG
 LCX
 LCM
 STM
 STG
 STS/STL
 STR2
 UCA2
 ULK*
 JSK/M2
 JSG
 JSC3/JSC4
 USSD
 UFCD
 USC
 JSB3
 LMB
 LML
 HCM
 HCA
 LBC
 CAC4
 UCAC2
 CAC-N
 UCAC-N
 RCC2
 RCS
 PCC
 SHC
 MCP
 GLC
 MFC
 BBS
 RRC
 GRC
 RV3*
 NHS
 HR
 LN
 Hand
 Chuk
 MecHnd/Chuk
 ShkAbs
 FJ
 FK
 SpdContr
 Ending



Linear slide cylinder Double acting/fine speed
 Clean-room specifications

LCR-F-P7* Series

● Bore size: $\phi 12/\phi 16/\phi 20/\phi 25$



Specifications

Descriptions		LCR-P7*			
Bore size mm		$\phi 12$	$\phi 16$	$\phi 20$	$\phi 25$
Actuation		Double acting			
Working fluid		Compressed air			
Max. working pressure MPa		0.7 (≈ 100 psi, 7 bar)			
Min. working pressure MPa		0.15 (≈ 22 psi, 1.5 bar)			
Proof pressure MPa		1.05 (≈ 150 psi, 10.5 bar)			
Ambient temperature $^{\circ}\text{C}$		5 (41°F) to 60 (140°F)			
Port size	Main body side	M5		Rc1/8	
	Main body back	M3		M5	Rc1/8
Pressure relief port size		M5		Rc1/8	
Stroke tolerance mm		+2.0 0 (*1)			
Working piston speed mm/s		5 to 200 (no load at 0.5 MPa (≈ 73 psi, 5 bar))			
Cushion		With rubber cushion			
Lubrication		Not available			
Allowable absorbed energy J		Refer to Table 3 on page 124.			

*1: Note that there will be a slight gap between the end plate and floating bush if no stopper is attached.

*2: Contact CKD for $\phi 6$ and $\phi 8$.

*3: The stroke adjusting stopper for 0.3 MPa and over working pressure is the metal sealing.

Stroke length

Bore size (mm)	Standard stroke length (mm)
$\phi 12$	10, 20, 30, 40, 50, 75, 100
$\phi 16$	10, 20, 30, 40, 50, 75, 100, 125
$\phi 20$	10, 20, 30, 40, 50, 75, 100, 125, 150
$\phi 25$	10, 20, 30, 40, 50, 75, 100, 125, 150

Note: Products with stroke lengths other than the above are not available.

Dimensions

Same as double acting/single rod clean-room specifications. Refer to pages 104 to 112.

Theoretical thrust table

Refer to page 125.

Switch specifications

- 1-color/2-color display

Descriptions	Reed 2-wire				Proximity 2-wire		Proximity 3-wire		
	T0H/T0V		T5H/T5V		T2H/T2V	T2WH/ T2WV	T3H/ T3V	T3PH/T3PV (custom)	T3WH/ T3WV
Applications	For programmable controller, relay		For programmable controller, relay, IC circuit (without indicator lamp), serial connection		Dedicated for programmable controller		For programmable controller, relay		
Output method	-		-		-		NPN output	PNP output	NPN output
Power supply voltage	-		-		-		10 to 28 VDC		
Load voltage	12/24 VDC	110 VAC	5/12/24 VDC	110 VAC	10 to 30 VDC	24 VDC ±10%	30 VDC or less		
Load current	5 to 50 mA	7 to 20 mA	50 mA or less	20 mA or less	5 to 20 mA		100 mA or less	50 mA or less	
Indicator lamp	LED (Lit when ON)		Without indicator lamp		LED (Lit when ON)	Red/green LED (Lit when ON)	LED (Lit when ON)	Yellow LED (Lit when ON)	Red/green LED (Lit when ON)
Leakage current	0 mA				1 mA or less		10 µA or less		
Weight	g 1 m:18 3 m:49 5 m:80								

Descriptions	Proximity 2-wire		Proximity 3-wire		Proximity 2-wire		Proximity 3-wire		
	F2S		F3S		F2H/F2V	F2YH/ F2YV	F3H/F3V	F3PH/F3PV (custom order)	F3YH/ F3YV
Applications	Dedicated for programmable controller		For programmable controller, relay		Dedicated for programmable controller		For programmable controller, relay		
Output method	-		NPN output		-		NPN output	PNP output	NPN output
Power supply voltage	-		10 to 28 VDC		-		10 to 28 VDC	4.5 to 28 VDC	10 to 28 VDC
Load voltage	10 to 30 VDC		30 VDC or less		10 to 30 VDC	24 VDC ±10%	30 VDC or less		
Load current	5 to 20 mA		50 mA or less		5 to 20 mA		100 mA or less	50 mA or less	
Indicator lamp	LED (Lit when ON)		LED (Lit when ON)		Yellow LED (Lit when ON)	Red/green LED (Lit when ON)	Yellow LED (Lit when ON)		Red/green LED (Lit when ON)
Leakage current	1 mA or less		10 µA or less		1 mA or less		10 µA or less		
Weight	g 1 m:10 3 m:29								

*1 : The T0/T5 switch can also be used with 220 VAC. Contact CKD about working conditions.

*2 : Refer to Ending Page 1 for other switch specifications.

*3 : Dimensions depend on switch model No. Refer to Ending Pages 18 and 23 for details.

Cylinder weight

- Clean-room specifications

(Unit: g)

Bore size (mm)	Fine speed Stroke length (mm)								
	10	20	30	40	50	75	100	125	150
φ12	400	410	410	450	480	610	700	-	-
φ16	620	630	630	680	740	970	1,100	1,240	-
φ20	1,160	1,170	1,180	1,260	1,350	1,650	1,860	2,070	2,280
φ25	2,010	2,030	2,040	2,150	2,250	2,740	3,010	3,280	3,550

- Weight of variation/option (stopper)

(Unit: g)

Bore size (mm)	Option/stopper code	
	S1 to S4	S5/S6
φ12	70	100
φ16	110	150
φ20	170	250
φ25	290	380

- LCW
- LCR
- LCG
- LCX
- LCM
- STM
- STG
- STS/STL
- STR2
- UCA2
- ULK*
- JSK/M2
- JSG
- JSC3/JSC4
- USSD
- UFCD
- USC
- JSB3
- LMB
- LML
- HCM
- HCA
- LBC
- CAC4
- UCAC2
- CAC-N
- UCAC-N
- RCC2
- RCS
- PCC
- SHC
- MCP
- GLC
- MFC
- BBS
- RRC
- GRC
- RV3*
- NHS
- HR
- LN
- Hand
- Chuk
- MecHnd/Chuk
- ShkAbs
- FJ
- FK
- SpdContr
- Ending

LCR-F-P7* Series

- LCW
- LCR
- LCG
- LCX
- LCM
- STM
- STG
- STS/STL
- STR2
- UCA2
- ULK*
- JSK/M2
- JSG
- JSC3/JSC4
- USSD
- UFCD
- USC
- JSB3
- LMB
- LML
- HCM
- HCA
- LBC
- CAC4
- UCAC2
- CAC-N
- UCAC-N
- RCC2
- RCS
- PCC
- SHC
- MCP
- GLC
- MFC
- BBS
- RRC
- GRC
- RV3*
- NHS
- HR
- LN
- Hand
- Chuk
- MecHnd/Chuk
- ShkAbs
- FJ
- FK
- SpdContr
- Ending

How to order

Without switch (built-in magnet for switch)

LCR-F-12-40-S506-DT-P72

With switch (built-in magnet for switch)

LCR-F-12-40-F2H*-R-S506-DT-P72

Model No.

A Bore size

B Stroke length

C Switch model No.

G Clean-room specifications

D Switch quantity

E Stopper

F Option

⚠ Precautions for model No. selection

- *1 : For the port position, refer to the stopper dimensions on page 112.
- *2 : The port positions of the standard without stopper are ① and ③ in the figure below.
- *3 : Can be selected for the type with stopper only.
- *4 : Select when using rear piping.
- *5 : The stroke adjusting stopper for 0.3 MPa and over working pressure is the metal sealing.
- *6 : When changing the stopper position from the head side to the rod side, the stopper must be purchased separately according to the stroke length and adjustable stroke length. Refer to "Precautions when purchasing discrete stopper" on page 67. Adjustable stroke lengths of 15 mm and 25 mm may not be possible depending on the stroke length.

[Example of model No.]

LCR-F-12-40-F2H*-R-S1DT-P72

Model: Linear slide cylinder Double acting/fine speed (clean-room specifications) LCR-F-P7*

- A** Bore size : φ12
- B** Stroke length : 40 mm
- C** Switch model No. : Proximity/2-wire Axial lead wire
- D** Switch quantity : 1 on rod side
- E** Stopper : Stroke adjusting stopper Stopper position ①
- F** Option : Port on the stopper: Side and bottom ports Stopper block material: Steel (nitriding)
- G** Clean-room specifications : Exhaust port

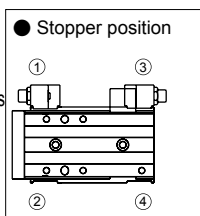

Code	Content
A Bore size	
12	φ12
16	φ16
20	φ20
25	φ25

		Bore size (φ)			
		12	16	20	25
B Stroke length (mm)					
10	10	●	●	●	●
20	20	●	●	●	●
30	30	●	●	●	●
40	40	●	●	●	●
50	50	●	●	●	●
75	75	●	●	●	●
100	100	●	●	●	●
125	125		●	●	●
150	150			●	●

Axial lead wire		Radial lead wire		Contact	Voltage		Indicator lamp	Lead wire	Bore size			
					AC	DC			φ12	φ16	φ20	φ25
F2S*				Proximity	●	●	1-color display	2-wire				
F3S*					●	●		3-wire				
F2H*		F2V*		Proximity	●	●	display	2-wire				
F3H*		F3V*			●	●		3-wire	●			
F3PH*		F3PV*		Proximity	●	●	1 color display (PNP output) (custom)	3-wire				
F2YH*		F2YV*			●	●		2-wire				
F3YH*		F3YV*		Proximity	●	●	2-color display	3-wire				
T0H*		T0V*			●	●		2-wire				
T5H*		T5V*		Reed	●	●	1-color display no indicator lamp	2-wire				
T2H*		T2V*			●	●		2-wire				
T3H*		T3V*		Proximity	●	●	1-color display	3-wire		●	●	●
T3PH*		T3PV*			●	●		3-wire				
T2WH*		T2WV*		Proximity	●	●	1 color display (PNP output) (custom)	2-wire				
T3WH*		T3WV*			●	●		3-wire				

Lead wire length		Bore size			
Blank	1 m (standard)				●
3	3 m (option)				●
5	5 m (option)			●	

D Switch quantity		Bore size			
R	1 on rod side				●
H	1 on head side				●
D	2				●

E Stopper		Bore size			
Blank	No option				●

S Stroke adjusting stopper		Bore size				
5 mm stroke adjustment on one side						
S1**	Stopper position ① (can be changed to ④)	Stopper installation position				●
S2**	Stopper position ② (can be changed to ③)*6					●
S3**	Stopper position ③ (can be changed to ②)*6					●
S4**	Stopper position ④ (can be changed to ①)*6					●
S5**	Stopper position ①,③					●
S6**	Stopper position ②,④					●

** part	Adjustable stroke range	Return end	Compatible with all. ▲ Compatible with some.*3
Blank	5 mm or none	5 mm or none	●
02	15 mm or none	15 mm or none	●
03	25 mm or none	25 mm or none	●
04	15 mm	5 mm	▲
05	25 mm	5 mm	▲
06	5 mm	15 mm	▲
07	5 mm	25 mm	▲

F Option		Bore size			
Blank	Port on the stopper: without port				●
D	Port on the stopper: side and bottom ports				● *1, *3
Blank	Stopper block material: steel				●
T	Stopper block material: steel (nitriding)				● *3

Plug attached		Bore size			
Blank	None				
N	With side piping port plug (not available for φ25)				*4

G Clean-room specifications		Structure			
P72	Exhaust port				
P73	Vacuum treatment				

Stopper model No. selection method

Stopper combination table

Model No. - [①②Stopper] [③ Adjustable stroke range]

Example) LCR-F-12-40- [S5] [06]-P7*

For stroke adjusting stopper -S

	Stopper adjusting range		Stopper model No. [①②]						
	Protruding end	Return end	[S1]	[S2]	[S3]	[S4]	[S5]	[S6]	
	Adjustable stroke range Model No. [③]	Blank	5 mm or none	5 mm or none	[S1]	[S2]	[S3]	[S4]	[S5]
[02]		15 mm or none	15 mm or none	[S102]	[S202]	[S302]	[S402]	[S502]	[S602]
[03]		25 mm or none	25 mm or none	[S103]	[S203]	[S303]	[S403]	[S503]	[S603]
[04]		15 mm	5 mm					[S504]	[S604]
[05]		25 mm	5 mm					[S505]	[S605]
[06]		5 mm	15 mm					[S506]	[S606]
[07]		5 mm	25 mm					[S507]	[S607]

- : Stroke adjusting stopper (adjusting range 5 mm)
- : Stroke adjusting stopper (adjusting range 15 mm)
- : Stroke adjusting stopper (adjusting range 25 mm)

▲ shows the piping direction.

- LCW
- LCR
- LCG
- LCX
- LCM
- STM
- STG
- STS/STL
- STR2
- UCA2
- ULK*
- JSK/M2
- JSG
- JSC3/JSC4
- USSD
- UFCD
- USC
- JSB3
- LMB
- LML
- HCM
- HCA
- LBC
- CAC4
- UCAC2
- CAC-N
- UCAC-N
- RCC2
- RCS
- PCC
- SHC
- MCP
- GLC
- MFC
- BBS
- RRC
- GRC
- RV3*
- NHS
- HR
- LN
- Hand
- Chuk
- MecHnd/Chuk
- ShkAbs
- FJ
- FK
- SpdContr
- Ending

Selection table

●: Available —: Not available

Bore size (mm)	Stopper code	Adjustment length code																																									
		S1							S2							S3							S4							S5							S6						
		Blank	02	03	Blank	02	03	Blank	02	03	Blank	02	03	Blank	02	03	Blank	02	03	04	05	06	07	Blank	02	03	04	05	06	07													
φ12 to φ25	10st	●	—	—	●	—	—	●	●	—	●	●	—	●	—	—	—	—	—	●	—	●	—	—	—	—	—	●	—														
	20st	●	●	—	●	●	—	●	●	●	●	●	●	●	●	●	—	●	—	●	●	●	●	—	●	—	●	●	●														
	30st up	●	●	●	●	●	●	●	●	●	●	●	●	●	●	●	●	●	●	●	●	●	●	●	●	●	●	●	●														

STEP 1

① Calculate the load and the moment of impact occurring at the stroke end in different directions.

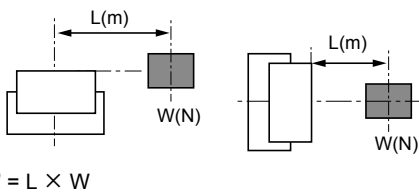
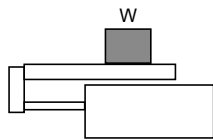
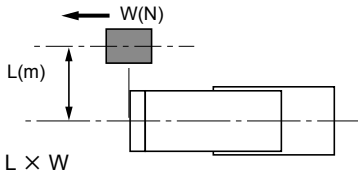
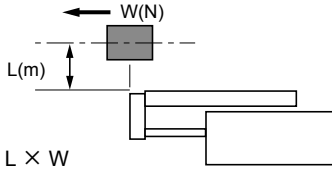

Obtain an approximate G coefficient in [Table 1].

[Table 1] V_a (average speed) = $\frac{\text{Travel distance}}{\text{Travel time}}$ (m/s)

V_a Average speed (m/s)	V_m Stroke end speed (m/s)	G coefficient
to 0.07	to 0.1	5
to 0.2	to 0.3	14
to 0.27	to 0.4	19
to 0.35	to 0.5	24

G coefficient =

$M1' \times G$ = (N·m)

$M2'$ = (N·m)

$M3' \times G$ = (N·m)

W' = (N)

$E' = \frac{1}{2} \times (m + m_\alpha) \times V_m^2$

= (J)
($m \approx \frac{W}{9.8}$)

② Select a temporary bore size that satisfies the following formula.

$$M1'T = \frac{M1' \times G}{M1'max} + \frac{M2'}{M2'max} + \frac{M3' \times G}{M3'max} + \frac{W'}{W'max} < 1$$

$E' < E_{max}$

$M1'T$: Resultant moment (must be smaller than 1)

G : G coefficient

$W'max$: Max. allowable value of W' (from Table 2)

$M1'max$: Max. allowable value of $M1'$ (from Table 2)

$M2'max$: Max. allowable value of $M2'$ (from Table 2)

$M3'max$: Max. allowable value of $M3'$ (from Table 2)

E_{max} : Max. allowable value of E_o (from Table 3)

m_α : Table weight (from Table 4)

[Table 2] Allowable static load

Bore size	Stroke length (mm)	Vertical load $W'max(N)$	Bending moment $M1' max (N·m)$	Radial moment $M2' max (N·m)$	Torsion moment $M3' max (N·m)$
φ6	10 to 30	140	1.7	3.5	1.7
	40 to 50	186	10.7	5.6	10.7
φ8	10 to 30	140	1.7	3.5	1.7
	40 to 75	186	10.7	5.6	10.7
φ12	10 to 50	220.8	5.7	9.8	5.7
	75 to 100		22.2		22.2
φ16	10 to 50	380.8	17.8	19.2	17.8
	75 to 125		37.3		37.3
φ20	10 to 50	548.8	31.1	37.6	31.1
	75 to 150		56.2		56.2
φ25	10 to 50	961.5	65.1	116.3	65.1
	75 to 150		127.5		127.5

Note: When attaching a load to the end plate, even if selecting long stroke length (φ6, 8: 40 or more, φ12 or more: 75 or more), calculate the allowable values with short stroke length (φ6, 8: 30 or less, φ12 or more: 50 or less).

[Table 3] LCR allowable absorbed energy (E_o)

Bore size	Standard (J)	With stroke adjusting stopper (J)	With shock absorber stopper (J)
φ6	0.025	0.0032	0.14
φ8	0.058	0.0032	0.25
φ12	0.112	0.014	0.25
φ16	0.176	0.043	0.65
φ20	0.314	0.055	1.3
φ25	0.314	0.14	1.3

[Table 4] Table weight

(Unit: kg)

Bore size	Stroke length (mm)									P72/P73 added	B/BL added
	10	20	30	40	50	75	100	125	150		
φ6	0.035	0.035	0.04	0.05	0.055	-	-	-	-	0.005	0.030
φ8	0.055	0.055	0.06	0.075	0.08	0.095	-	-	-	0.015	0.030
φ12	0.13	0.13	0.13	0.14	0.155	0.195	0.225	-	-	0.025	0.060
φ16	0.185	0.185	0.185	0.2	0.215	0.285	0.325	0.365	-	0.035	0.070
φ20	0.29	0.29	0.29	0.315	0.335	0.415	0.47	0.525	0.585	0.045	0.140
φ25	0.505	0.505	0.505	0.54	0.58	0.745	0.835	0.925	1.015	0.075	0.310

STEP 2

Next, obtain a more accurate load factor, effective thrust, stroke end speed and resultant moment.

● Calculate the load factor.

$$\alpha = \frac{F_o}{F} \times 100 [\%]$$

α : Load factor

F_o : Force (N) required to move the workpiece

F : Cylinder theoretical thrust (N)
[Table 5]

[Table 5] Theoretical thrust table

(Unit: N)

Bore size (mm)	Operating direction	Working pressure MPa						
		0.15	0.2	0.3	0.4	0.5	0.6	0.7
φ6	PUSH	8	11	17	23	28	34	40
	PULL	6	8	13	17	21	25	30
φ8	PUSH	15	20	30	40	50	60	70
	PULL	11	15	23	30	38	45	53
φ12	PUSH	34	45	68	90	113	136	158
	PULL	25	34	51	68	85	102	119
φ16	PUSH	60	80	121	161	201	241	281
	PULL	52	69	104	138	173	207	242
φ20	PUSH	94	126	188	251	314	377	440
	PULL	79	106	158	211	264	317	369
φ25	PUSH	147	196	295	393	491	589	687
	PULL	124	165	247	330	412	495	577

For horizontal operation	For vertical operation
$F_o = F_w$	$F_o = W + F_w$
FW: $W \times 0.2$ Note (N)	
W: Load (N)	

Note: Coefficient of friction

[Table 6] Load factor guidelines

Working pressure MPa	Load factor (%)
0.2 to 0.3	$\alpha \leq 40$
0.3 to 0.6	$\alpha \leq 50$
0.6 to 0.7	$\alpha \leq 60$

STEP 3

Obtain the stroke end speed (V_m) and G coefficient from the average speed (V_a) and load factor obtained in STEP 2.

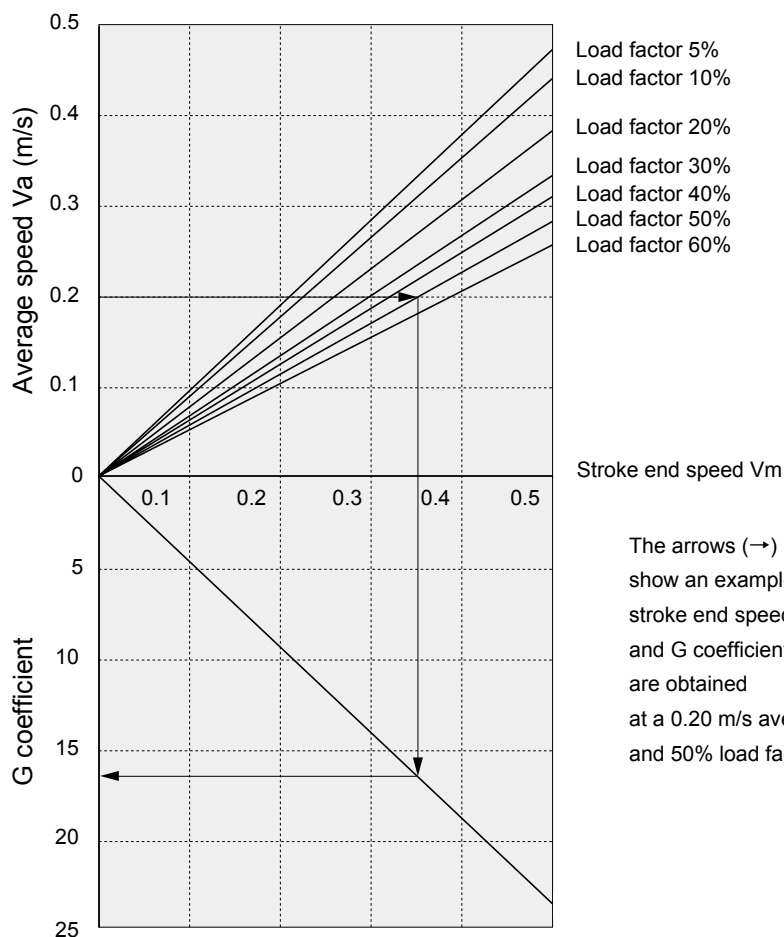

Graph of speed and G coefficient

G coefficient =

STEP 4

Calculate the resultant moment (M_T) from the G coefficient and stroke end speed (V_m) obtained in STEP 3.

$$M1' \times G = \text{[] (N}\cdot\text{m)}$$

$$M2' = \text{[] (N}\cdot\text{m)}$$

$$M3' \times G = \text{[] (N}\cdot\text{m)}$$

$$W' = \text{[] (N)}$$

$$M_T = \frac{M1' \times G}{M1'\text{max}} + \frac{M2'}{M2'\text{max}} + \frac{M3' \times G}{M3'\text{max}} + \frac{W'}{W'\text{max}} = \text{[]}$$

Obtain M_T (resultant moment during movement). (Note that it differs from that obtained in STEP 1.)

● Vertical load: W (N)

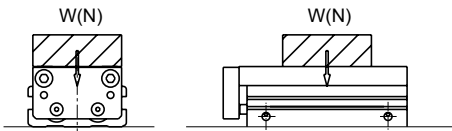

● Bending moment: $M1$ (N·m)

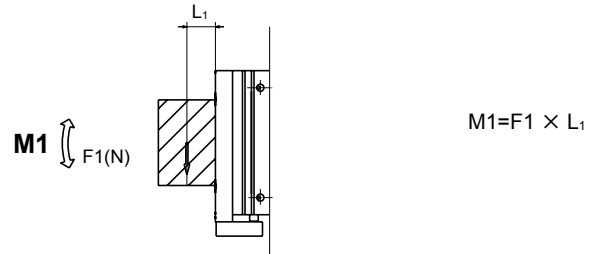

$$M1 = F1 \times L1$$

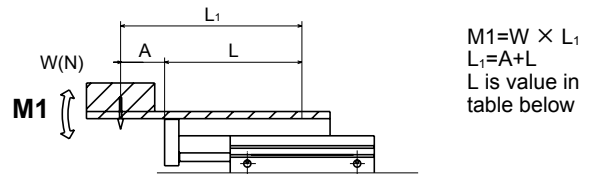

$$M1 = W \times L1$$

$$L1 = A + L$$

L is value in table below

● Radial moment: $M2$ (N·m)

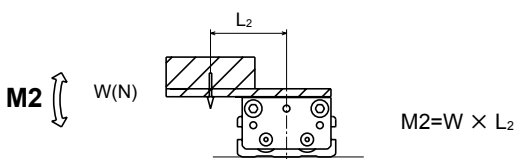

$$M2 = W \times L2$$

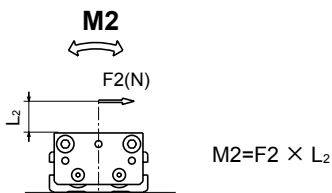

$$M2 = F2 \times L2$$

● Torsion moment: $M3$ (N·m)

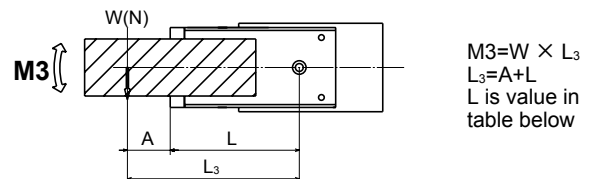

$$M3 = W \times L3$$

$$L3 = A + L$$

L is value in table below

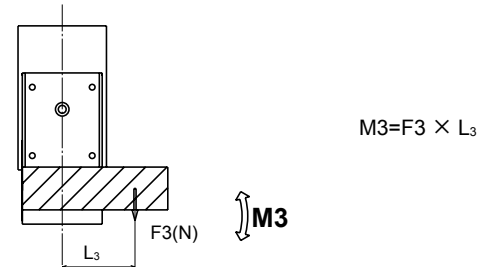

$$M3 = F3 \times L3$$

L value

Unit (m)

Bore size	Stroke length									P72/P73 added	B/BL added
	10	20	30	40	50	75	100	125	150		
φ6	0.048	0.048	0.058	0.073	0.083	-	-	-	-	0.012	0.0165
φ8	0.048	0.048	0.058	0.072	0.082	0.107	-	-	-	0.020	0.0145
φ12	0.067	0.067	0.067	0.077	0.087	0.117	0.142	-	-	0.020	0.018
φ16	0.071	0.071	0.071	0.081	0.091	0.124	0.149	0.174	-	0.020	0.019
φ20	0.081	0.081	0.081	0.091	0.101	0.126	0.151	0.176	0.201	0.025	0.020
φ25	0.085	0.085	0.085	0.095	0.105	0.14	0.165	0.19	0.215	0.025	0.023

$$M1=M1 = \text{[]} \text{ (N}\cdot\text{m)}$$

$$M2=M2 = \text{[]} \text{ (N}\cdot\text{m)}$$

$$M3=M3 = \text{[]} \text{ (N}\cdot\text{m)}$$

$$W=W = \text{[]} \text{ (N)}$$

$$M_T = \frac{M1}{M1_{max}} + \frac{M2}{M2_{max}} + \frac{M3}{M3_{max}} + \frac{W}{W_{max}} = \text{[]}$$

M_T : Synthesis of moment

W_{max} : Max. allowable value of W (from Table 7)

$M1_{max}$: Max. allowable value of M1 (from Table 7)

$M2_{max}$: Max. allowable value of M2 (from Table 7)

$M3_{max}$: Max. allowable value of M3 (from Table 7)

E_{max} : Max. allowable value of E_o (from Table 3)

[Table 7] Allowable running load

Bore size	Stroke length (mm)	Vertical load W_{max} (N)	Bending moment $M1_{max}$ (N·m)	Radial moment $M2_{max}$ (N·m)	Torsion moment $M3_{max}$ (N·m)
φ6	10 to 30	14	0.17	0.35	0.17
	40 to 50	15.5	0.89	0.47	0.89
φ8	10 to 30	14	0.17	0.35	0.17
	40 to 75	15.5	0.89	0.47	0.89
φ12	10 to 50	27.6	0.71	1.2	0.71
	75 to 100		2.2		2.2
φ16	10 to 50	47.6	1.9	2.4	1.9
	75 to 125		4.6		4.6
φ20	10 to 50	68.6	3.4	4.7	3.4
	75 to 150		7.0		7.0
φ25	10 to 50	128.2	7.6	15.5	7.6
	75 to 150		17.0		17.0

Note: When attaching a load to the end plate, even if selecting long stroke length (φ6, 8: 40 or more, φ12 or more: 75 or more), calculate the allowable values with short stroke length (φ6, 8: 30 or less, φ12 or more: 50 or less).

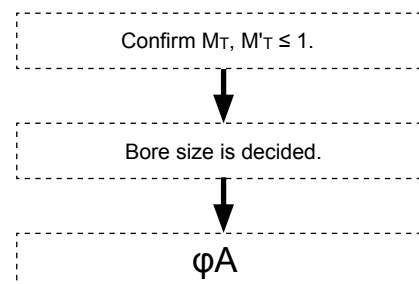

STEP 5

Confirming allowable absorbed energy

$$E = \frac{1}{2} \times (m + m_\alpha) \times Vm^2$$

E : Kinetic energy at workpiece end (J)

m : Load weight (kg) ($m \approx \frac{W(N)}{9.8}$)

m_α : Table weight (from Table 4)

Vm : Stroke end speed (m/s)

E_{max} : Max. allowable value of E_o (from Table 3)

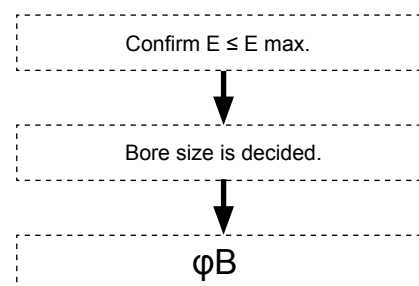

STEP 6

Bore size decided in STEP 4
(load conditions)

Bore size decided in STEP 5
(allowable absorbed energy)

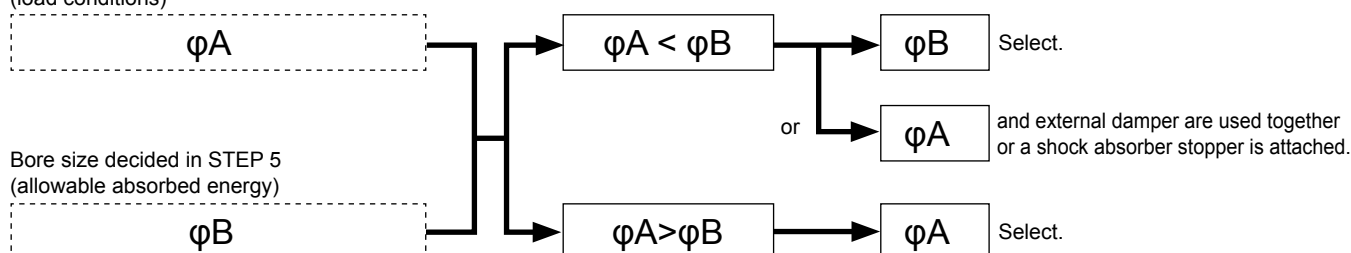

- LCW
- LCR
- LCG
- LCX
- LCM
- STM
- STG
- STS/STL
- STR2
- UCA2
- ULK*
- JSK/M2
- JSG
- JSC3/JSC4
- USSD
- UFCD
- USC
- JSB3
- LMB
- LML
- HCM
- HCA
- LBC
- CAC4
- UCAC2
- CAC-N
- UCAC-N
- RCC2
- RCS
- PCC
- SHC
- MCP
- GLC
- MFC
- BBS
- RRC
- GRC
- RV3*
- NHS
- HR
- LN
- Hand
- Chuk
- MecHnd/Chuk
- ShkAbs
- FJ
- FK
- SpdContr
- Ending

Selection confirmation graph of shock absorber stopper

1. This is a simplified confirmation graph for shock absorber stoppers. The area inside the graph is the usable range.
Select a bore size for shock absorber mounting within the usable range.
2. Simplified selection graph lists the pneumatic pressure value used for the cylinder at 0.5 MPa.
3. The absorbed energy of the shock absorber varies depending on the temperature. The simplified confirmation graph lists the value at room temperature.
4. Colliding object weight is the sum of load weight m and table weight m_a .

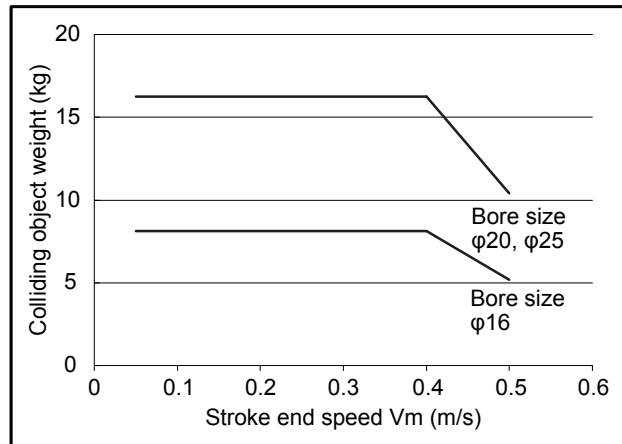
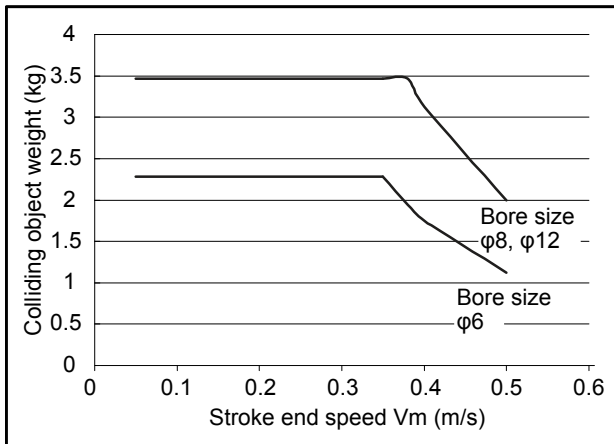

Displacement at point A

[Displacement of table due to M1 moment]

Displacement at the table end when load (F1) is applied to the table end

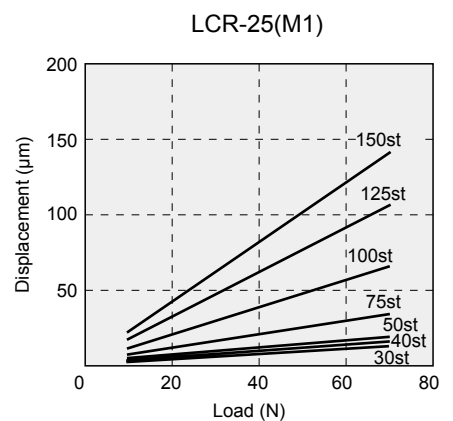
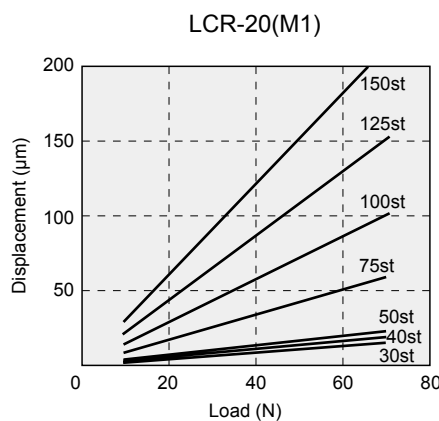
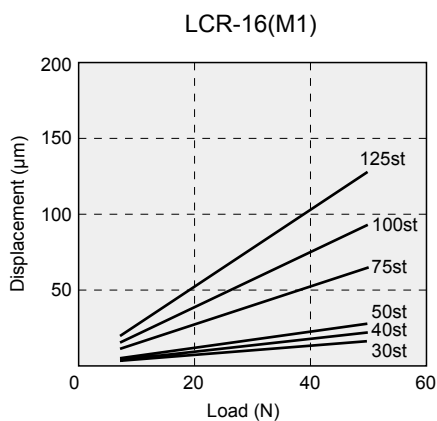
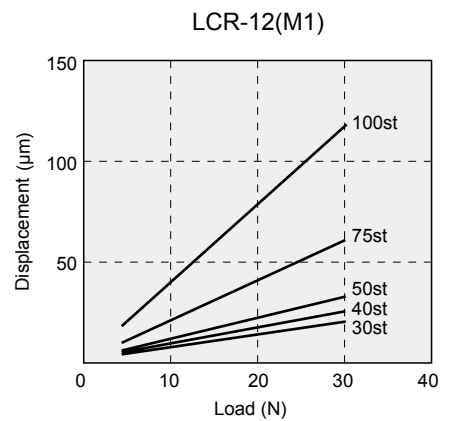
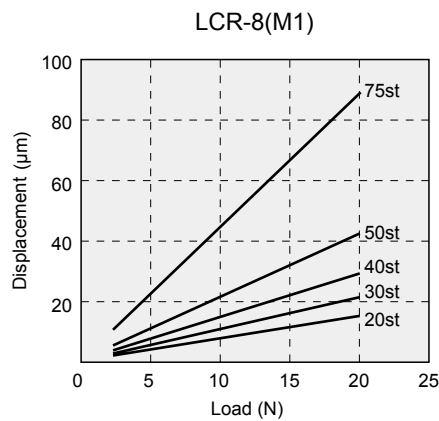
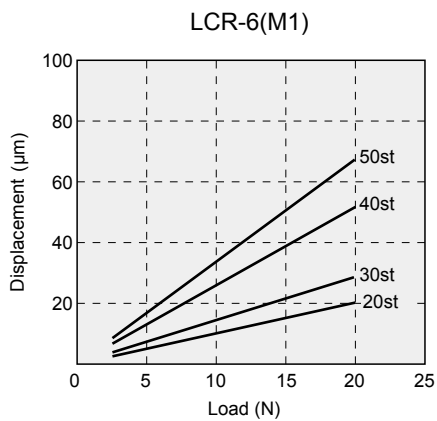
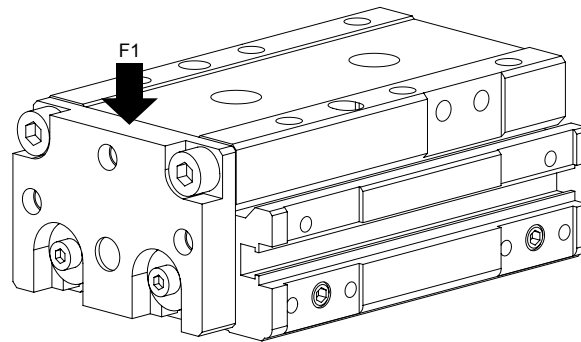

LCW
LCR
LCG
LCX
LCM
STM
STG
STS/STL
STR2
UCA2
ULK*
JSK/M2
JSG
JSC3/JSC4
USSD
UFCD
USC
JSB3
LMB
LML
HCM
HCA
LBC
CAC4
UCAC2
CAC-N
UCAC-N
RCC2
RCS
PCC
SHC
MCP
GLC
MFC
BBS
RRC
GRC
RV3*
NHS
HR
LN
Hand
Chuk
MecHnd/Chuk
ShkAbs
FJ
FK
SpdContr
Ending

Displacement at point A

[Displacement of table due to M2 moment]

Displacement at the table end (point A) when load (F2) is applied to a point L mm away from the center of the cylinder

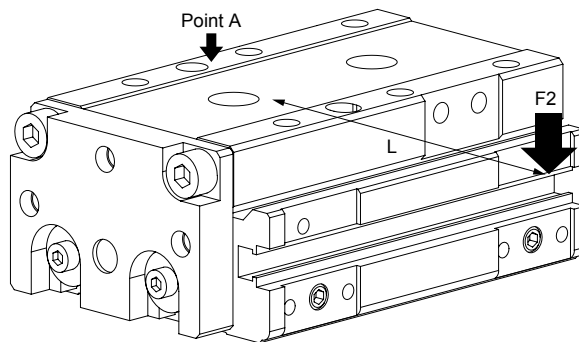

L value
 $\phi 6$: L= 70, $\phi 8$: L= 70
 $\phi 12$: L= 90, $\phi 16$: L=100
 $\phi 20$: L=100, $\phi 25$: L=200

LCR-6(M2)

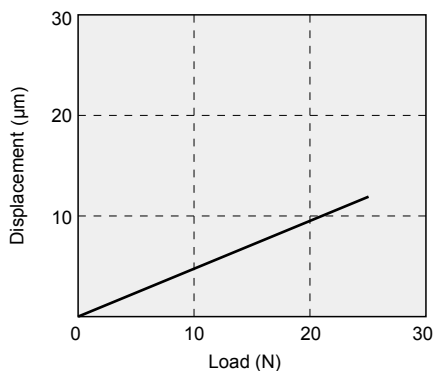

LCR-8(M2)

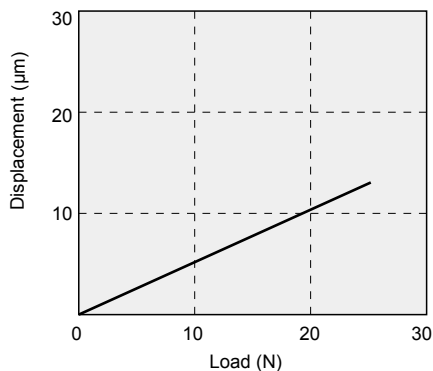

LCR-12(M2)

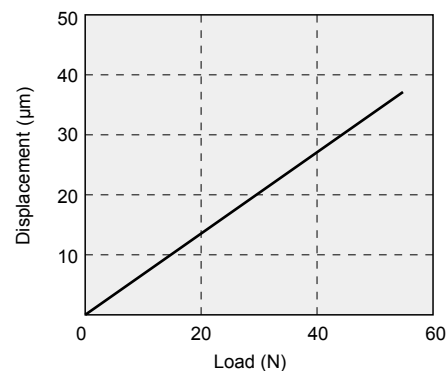

LCR-16(M2)

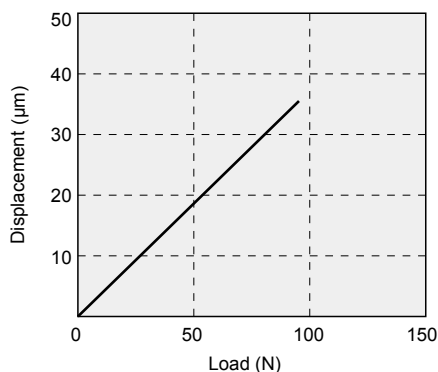

LCR-20(M2)

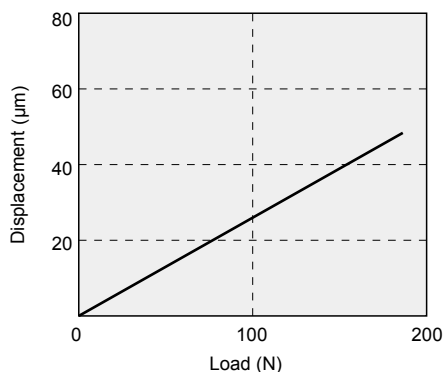

LCR-25(M2)

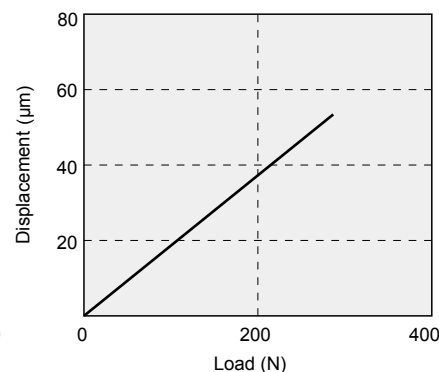

Displacement at point A

[Displacement of table due to M3 moment]

Displacement angle of the table when rotation moment (M3) is applied to the cylinder

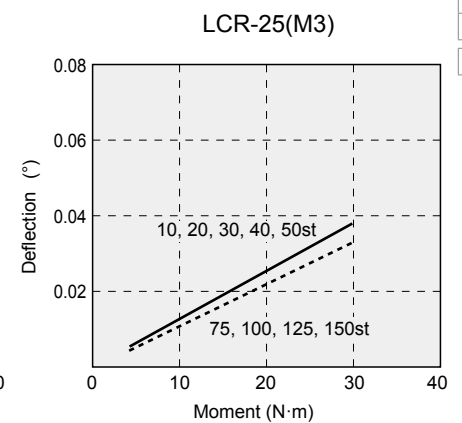
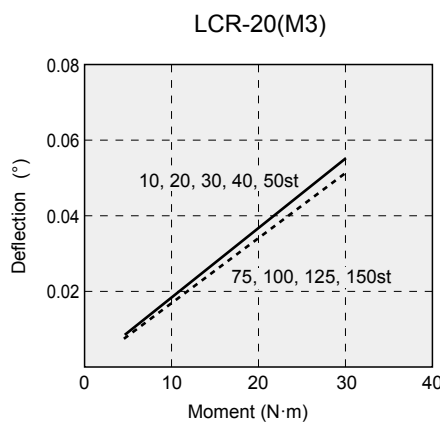
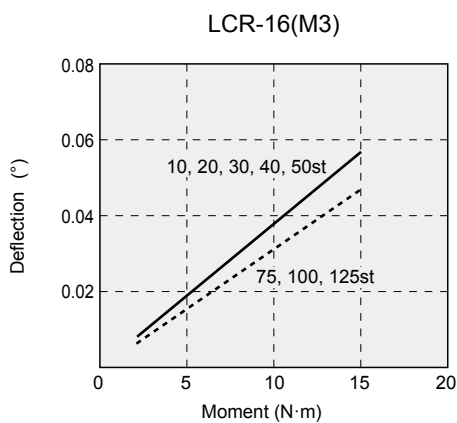
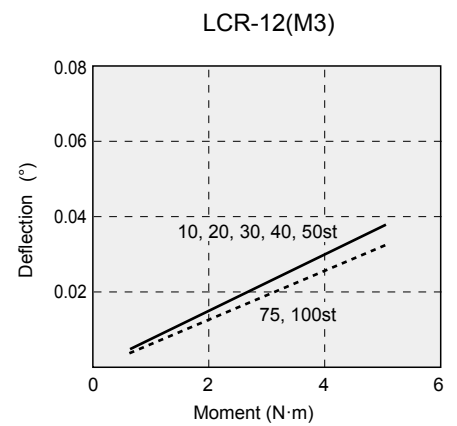
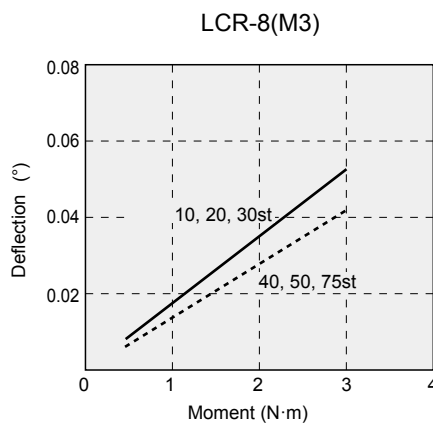
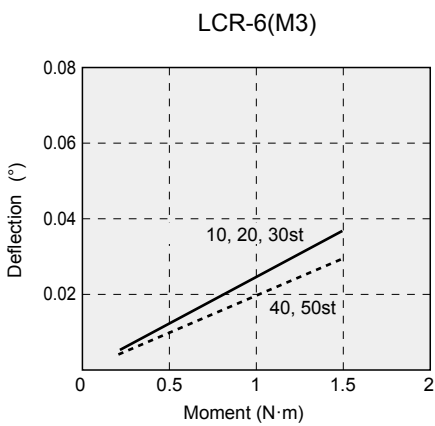
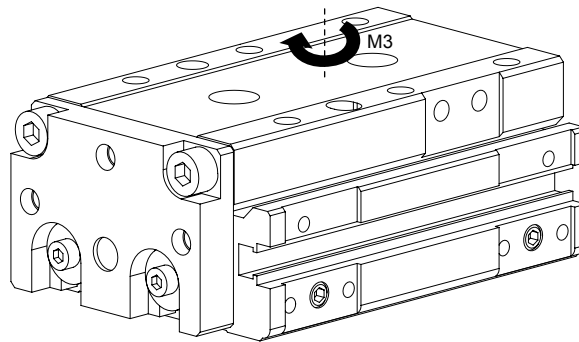

LCW
LCR
LCG
LCX
LCM
STM
STG
STS/STL
STR2
UCA2
ULK*
JSK/M2
JSG
JSC3/JSC4
USSD
UFCD
USC
JSB3
LMB
LML
HCM
HCA
LBC
CAC4
UCAC2
CAC-N
UCAC-N
RCC2
RCS
PCC
SHC
MCP
GLC
MFC
BBS
RRC
GRC
RV3*
NHS
HR
LN
Hand
Chuk
MecHnd/Chuk
ShkAbs
FJ
FK
SpdContr
Ending



Safety Precautions

Be sure to read this section before use.

Refer to Intro Page 73 for general information of the cylinder, and to Intro Page 80 for general information of the cylinder switch.

Product-specific cautions: Linear slide cylinder LCR Series

Design/selection

1. Common

CAUTION

■ When selecting the cylinder, follow the "LCR Selection guide" on pages 124 to 127.

■ Protect the cylinder with a cover to prevent damage and malfunction in a place where it is exposed to dripping water or oil, corrosive conditions or much dust.

Precautions for type with switch

- When using the T □ V switch with a stroke adjusting stopper (S3**/S4**/S5**/S6**) or shock absorber stopper (A3**/A4**/A5**/A6**), install the switch on the opposite side to the stopper. Otherwise the switch on the head side will make contact with the stopper.
- Be careful of the lead wire direction when designing the 30 mm or less stroke length, since a switch is installed in each groove of the body.

2. Position locking LCR-Q

CAUTION

■ Do not use 3-position valves.

Avoid using the cylinder in combination with 3-position (especially closed center metal seal) valves. If the port at the side where the lock mechanism is provided is pressurized, the lock cannot be engaged. Even if it is locked once, the air leaked from the valve enters the cylinder, and the lock may be released after a certain period of time.

3. Fine speed LCR-F

CAUTION

■ Use without lubrication.

Applying lubrication may cause changes in characteristics.

■ Assemble the speed controller near the cylinder.

When installed far from the cylinder, the speed becomes unstable.

Use the SC-M3/M5-F, SC3W, SCD-

M3/M5 or SC3U Series speed controllers.

■ In general, the speed is stabler at higher air pressure and lower load factor.

Use at a 50% or less load factor.

■ Stable speed control is achieved with a meter-out circuit.

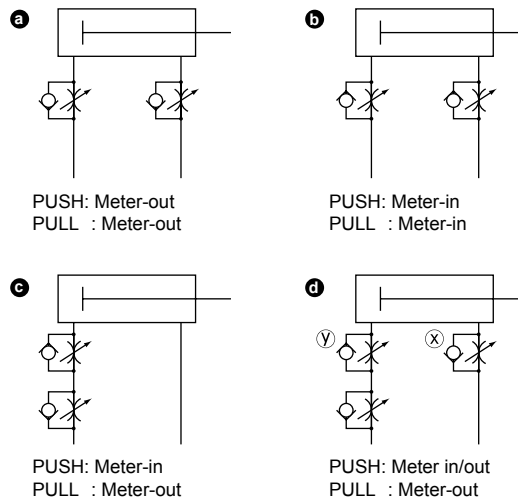

When fine speed activation is performed with operating direction PUSH for the single rod cylinder, the popping out phenomenon occurs when operation starts if the load resistance is low. For countermeasures, use the **b**, **c** or **d** circuit.

Note that circuit **d** is the most stable.

Speed adjustment method for PUSH operation of **d** circuit:

1. Set the speed with the speed controller x.
2. Restrict the speed with the speed controller y until there is no popping out.
3. Check the speed again.

(*1) When comparing **b**, **c** and **d**, operation is the most stable with the **d** circuit.

(*2) For vertical mounting, combine the cylinder with a meter-out circuit, as it will fall under its own weight when a meter-in circuit is used.

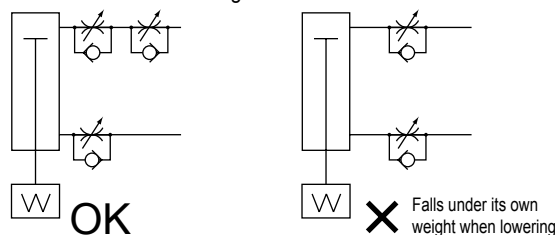

(*3) Use the circuit shown in the figure below for the serial connection of the speed controllers.

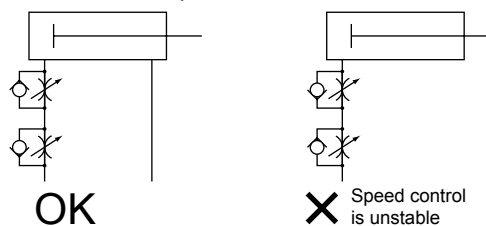

(Guidelines for pop-out generation)

Popping out occurs in the following cases.

· Thrust > Resistance

* Resistance: Thrust caused by residual pressure on the exhaust + { When using horizontally: frictional force caused by load side (in the fine speed, supply pressure = residual pressure) } { When using vertically: load self-weight

LCW
LCR
LCG
LCX
LCM
STM
STG
STS/STL
STR2
UCA2
ULK*
JSK/M2
JSG
JSC3/JSC4
USSD
UFCD
USC
JSB3
LMB
LML
HCM
HCA
LBC
CAC4
UCAC2
CAC-N
UCAC-N
RCC2
RCS
PCC
SHC
MCP
GLC
MFC
BBS
RRC
GRC
RV3*
NHS
HR
LN
Hand
Chuk
MechHnd/Chuk
ShkAbs
FJ
FK
SpdContr
Ending

Design/selection

- Do not apply a lateral load to the cylinder.
With a lateral load, operation will become unstable.

- Avoid using this product where vibration is present.
The product will be adversely affected by vibration and operation will become unstable.

Mounting, installation and adjustment

1. Common; when piping

CAUTION

- Apply adhesive to the M3 and M5 plugs (hexagon socket set screws) when changing the piping port position. (Low strength adhesives such as LOCTITE 222/221 or ThreeBond 1344 are recommended)

Piping port position and operating direction

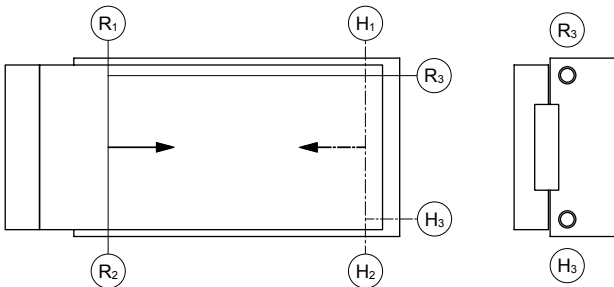

Ⓡ shows the rod side pressurizing port and Ⓜ the head side pressurizing port. When the product is shipped from the factory, ports other than Ⓡ₁ and Ⓜ₁ (Ⓡ₂ and Ⓜ₂ depending on the stopper position when a stopper is attached) are sealed with plugs.

Rear piping

Rear piping (ports Ⓡ₃ and Ⓜ₃ in the figure above) is possible except in the case of $\phi 6$ and position locking. Remove the plugs sealing ports Ⓡ₃ and Ⓜ₃ and seal ports Ⓡ₁ and Ⓜ₁ with the plugs shown in the table below.

Descriptions	Plug
LCR-6	No Ⓡ, Ⓜ port.
LCR-8	
LCR-12	M5 x 5 (Hexagon socket set screw)
LCR-16	
LCR-20	R 1/8 (Hexagon socket head cap taper thread plug)
LCR-25	Seal the Ⓡ and Ⓜ ports with the plugs removed from the Ⓡ, Ⓜ ports.

Prepare two separate plugs shown in the table above for $\phi 8$ to 20. Option with plug (refer to page 62) or discrete plug model No. (refer to page 68) are also available.

Precautions for piping fittings

Be sure to attach a speed controller during piping before use. The available fittings are as below.

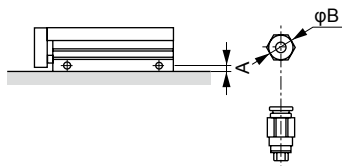

Descriptions Bore size (mm)	Port size	Port position dimension A	Applicable fitting	Fitting O.D. B
$\phi 6$	M3	4	SC3W-M3-4 SC3U-M3-4 SC3W-M3-3.2 SC3U-M3-3.2 GWS3-M3-S GWS4-M3-S	$\phi 8$ or less
$\phi 8$	M5	5.5	SC3W-M5-4 SC3W-M5-6 GWS4-M5-S GWS4-M5	$\phi 11$ or less
$\phi 12$		5.5	SC3W-M5-4 SC3W-M5-6 GWS4-M5-S GWS4-M5 GWL4-M5 GWL6-M5 GWS6-M5	
$\phi 16$	Rc1/8	6.5	SC3W-M5-4 SC3W-M5-6 GWS4-M5-S GWS4-M5 GWL4-M5 GWL6-M5 GWS6-M5	$\phi 13$ or less
$\phi 20$		8	SC3W-6-4,6,8 GWS4-6 GWS8-6 GWL6-6 GWS6-6 GWL4-6	
$\phi 25$		9		$\phi 15$ or less

2. Common; when installing

CAUTION

- Do not damage the surface flatness by denting or scratching the body (tube) mounting surface or the table surface.

In addition, make sure that the flatness of the mating surface for body and table mounting is 0.02 mm or less.

- Observe the following bolt insertion lengths and tightening torque when mounting the body. [Fig. 1]

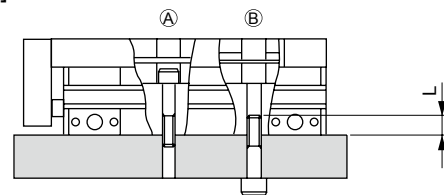

Descriptions	A		B		
	Bolt used	Tightening torque (N·m)	Bolt used	Tightening torque (N·m)	Max. insertion L (mm)
LCR-6	M3×0.5	0.6 to 1.1	M4×0.7	1.4 to 2.4	6
LCR-8	M3×0.5	0.6 to 1.1	M4×0.7	1.4 to 2.4	6
LCR-12	M4×0.7	1.4 to 2.4	M5×0.8	2.9 to 5.1	8
LCR-16	M5×0.8	2.9 to 5.1	M6×1.0	4.8 to 8.6	9
LCR-20	M5×0.8	2.9 to 5.1	M6×1.0	4.8 to 8.6	9
LCR-25	M6×1.0	4.8 to 8.6	M8×1.25	12.0 to 21.6	12

LCW
LCR
LCG
LCX
LCM
STM
STG
STS/STL
STR2
UCA2
ULK*
JSK/M2
JSG
JSC3/JSC4
USSD
UFCD
USC
JSB3
LMB
LML
HCM
HCA
LBC
CAC4
UCAC2
CAC-N
UCAC-N
RCC2
RCS
PCC
SHC
MCP
GLC
MFC
BBS
RRC
GRC
RV3*
NHS
HR
LN
Hand
Chuk
MecHnd/Chuk
ShkAbs
FJ
FK
SpdContr
Ending

Mounting, installation and adjustment

- Observe the following bolt insertion lengths and tightening torque when installing the jig on the slide table or end plate.

[Fig. 2]

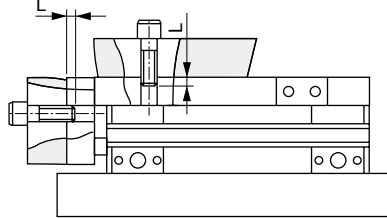

Descriptions	Table		
	Bolt used	Tightening torque (N·m)	Screw insertion L (mm)
LCR-6	M3×0.5	0.6	3
LCR-8	M3×0.5	0.6	3 to 4.5
LCR-12	M4×0.7	1.4	4 to 5.5
LCR-16	M5×0.8	2.9	5 to 6
LCR-20	M5×0.8	2.9	5 to 6
LCR-25	M6×1.0	4.8	6 to 7

Descriptions	End plate		
	Bolt used	Tightening torque (N·m)	Screw insertion L (mm)
LCR-6	M3×0.5	0.6	4.5 to 6
LCR-8	M3×0.5	0.6	4.5 to 7
LCR-12	M4×0.7	1.4	6 to 9
LCR-16	M5×0.8	2.9	7.5 to 9
LCR-20	M5×0.8	2.9	7.5 to 11
LCR-25	M6×1.0	4.8	9 to 11

- Observe the following tightening torque of bolts and nuts of the stopper.

[Fig. A]

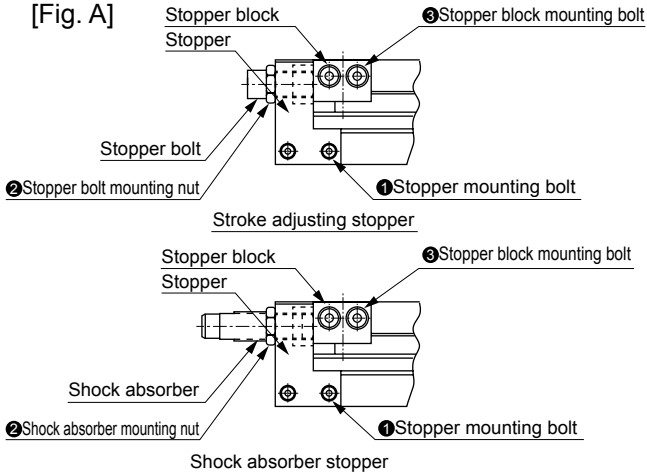

Model	① Stopper mounting bolt	② Stopper bolt mounting nut	③ Stopper block mounting bolt
	(N·m)	(N·m)	(N·m)
LCR-6	0.4 to 0.5	1.2 to 2.0	0.6 to 0.8
LCR-8	0.4 to 0.5	1.2 to 2.0	0.6 to 0.8
LCR-12	0.6 to 0.8	1.2 to 2.0	0.6 to 0.8
LCR-16	0.6 to 0.8	3.0 to 4.0	1.4 to 1.8
LCR-20	2.9 to 3.5	4.5 to 6.0	1.4 to 1.8
LCR-25	2.9 to 3.5	4.5 to 6.0	2.9 to 3.5

- The cylinder switch may malfunction if there is a magnetic substance such as a metal plate installed adjacently. To ensure safe operation, keep it 10 mm and over away from the cylinder surface or change the installation surface of the cylinder switch. (Common for all port sizes)

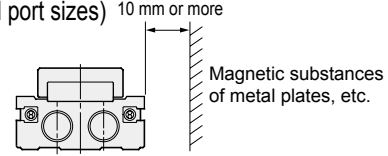

- The cylinder switches may accidentally function if the cylinders are close to each other. Keep the distance below between the surfaces of the cylinders. (Common for all port sizes)

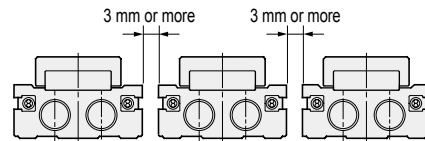

- CKD's shock absorber is a repair part. Replace it when the energy absorption performance has degraded or the operation is not smooth.

- When using a positioning hole, use a pin of dimensions that do not require press fitting. If a pin is press fitted, the load of press fitting may damage or distort the linear guide, lowering the accuracy. The recommended tolerance of a pin is JIS tolerance m6 or less.

3. Position locking LCR-Q

CAUTION

- The locking mechanism works at the stroke end. If the stopper is engaged on the way of the stroke by the external stopper, the locking mechanism may not work and the piston could fall. When setting a load, make sure to check that the lock mechanism functions before installing the product.
- Supply pressure equal to or higher than the min. working pressure to the port on the lock mechanism side.
- When the piping at the side where the lock mechanism is provided is long and thin, or when the speed controller is far away from the cylinder port, note that it takes time to engage the lock. Clogging in the silencer mounted on the EXH. port of the solenoid valve may also cause the same result.

Mounting, installation and adjustment

LCW
LCR
LCG
LCX
LCM
STM
STG
STS/STL
STR2
UCA2
ULK*
JSK/M2
JSG
JSC3/JSC4
USSD
UFCD
USC
JSB3
LMB
LML
HCM
HCA
LBC
CAC4
UCAC2
CAC-N
UCAC-N
RCC2
RCS
PCC
SHC
MCP
GLC
MFC
BBS
RRC
GRC
RV3*
NHS
HR
LN
Hand
Chuk
MecHnd/Chuk
ShkAbs
FJ
FK
SpdContr
Ending

4. Fine speed LCR-F

⚠ CAUTION

- Perform adjustment such as centering so that a lateral load is not applied to the cylinder. Adjust and install the sliding guide so that it is not twisted.
 - When the load or the resistance fluctuates, operation becomes unstable.
 - With a large difference between static friction and kinematic friction of the guide, operation becomes unstable.

5. With buffer LCR-B

- Depending on the speed and load, the buffer may function when operation is started, resulting in accidental operation of the switch. Adjust to an appropriate speed for the load before use.

- The type with buffer cannot be used vertically upward.

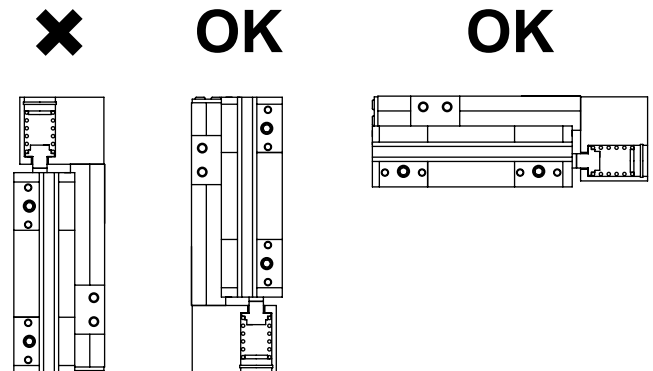

- Use a buffer of less than the buffer stroke length. Otherwise, malfunctions or damage may result.

Use/maintenance

1. Common

⚠ CAUTION

- For $\phi 6/8$, apply CGL grease (IKO), and for $\phi 12$ to 25, apply AFF grease (THK) to the guide rail surface after six months or when the number of operation cycles reaches one million, whichever comes first.

2. Position locking LCR-Q

⚠ WARNING

- If pressure is supplied to port (A) when both ports are not pressurized and the piston is locked, the lock may not be released or the piston rod may suddenly pop out just after the lock is released. This can be extremely hazardous. To release the lock mechanism, make sure to supply pressure to port (B). Check that load is not applied to the lock mechanism. Side where the lock mechanism is not provided.

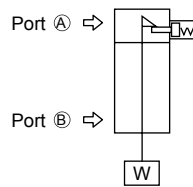

- For usage where the drop rate is increased using the quick exhaust valve, the lock may not release normally because the cylinder body starts operating before the lock pin. For the position locking cylinder, do not use the quick exhaust valve.

⚠ CAUTION

- If back pressure is applied to the locking mechanism, the lock may be released. Use a single solenoid valve, or an individual exhaust manifold.
- After the locking mechanism is manually operated, make sure to return the locking mechanism to the original state before use. Do not perform manual operation except for adjustment, as it is dangerous.

- When mounting or adjusting the cylinder, release the lock. If mounting work, etc., is done while the lock is engaged, the lock part may be damaged.
- Do not use multiple synchronized cylinders. Do not arrange so that 1 workpiece is moved by synchronizing 2 or more position locking cylinders. Lock release may fail for one of the cylinders.
- Use the speed controller with meter-out. If the meter-in control is used, the lock may not be able to be released.
- At the side where the lock mechanism is attached, be sure to use the cylinder from the stroke end. If the cylinder piston does not reach the stroke end, the lock may not be engaged or the lock may not be able to be released.
- How to unlock
By screwing the hexagon socket head cap screw (M3 x 20) into the stopper piston and pulling the bolt 3 mm with force of 20 N or more, the stopper piston moves and the lock is released. (when horizontally installed with no load and with the rod port pressurized). When the screw is released, the internal spring returns the stopper piston. When the stopper piston fits in the piston rod groove, the cylinder is locked.

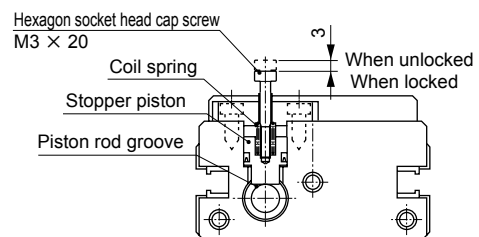

MEMO

LCW
LCR
LCG
LCX
LCM
STM
STG
STS/STL
STR2
UCA2
ULK*
JSK/M2
JSG
JSC3/JSC4
USSD
UFCD
USC
JSB3
LMB
LML
HCM
HCA
LBC
CAC4
UCAC2
CAC-N
UCAC-N
RCC2
RCS
PCC
SHC
MCP
GLC
MFC
BBS
RRC
GRC
RV3*
NHS
HR
LN
Hand
Chuk
MecHnd/Chuk
ShkAbs
FJ
FK
SpdContr
Ending