

fluimac[®]
pump solution



HELIOS

HELIOS POMPES PÉRISTALTIQUES

Made in
Italy

www.fluimac.com

FRANÇAIS 



HELIOS AS

Pompes de dosage péristaltiques - Basse pression
 Capacité jusqu'à environ 2800 l/h- tête de sortie de la pompe jusqu'à 4 bars
 Viscosité jusqu'à 15000cps - Aspiration possible jusqu'à 6mts

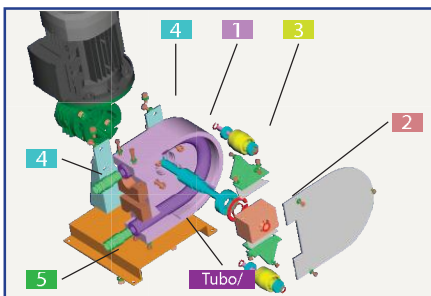

Elément	Matériaux
1 Corps de la pompe	Alliage d'aluminium
2 Rotor	Alliage d'aluminium
3 Rouleaux	PVC
As 25	Alliage d'aluminium
4 Base	Fer
5 Raccord de tuyau	AISI 304

Couplage spécial:

Raccord de tuyau en AISI 316, PVC, PTFE
 DIN
 TRI-CLAMPS
 ANSI, ISO, UNI, BRIDES

CARACTÉRISTIQUES TECHNIQUES

- Dosage et refoulement précis et reproductible
- Longue durée et grande fiabilité
- Auto-amorçante
- Fonctionnement à sec continu
- Plus faible coût de possession
- Maintenance simple et rapide

MATÉRIAUX DE TUYAUX DISPONIBLES:

- NR
- NBR
- Norprène®
- Silicone
- EPDM
- Pharmé®
- Tygon (AS25)
- Hypalon (AS25)



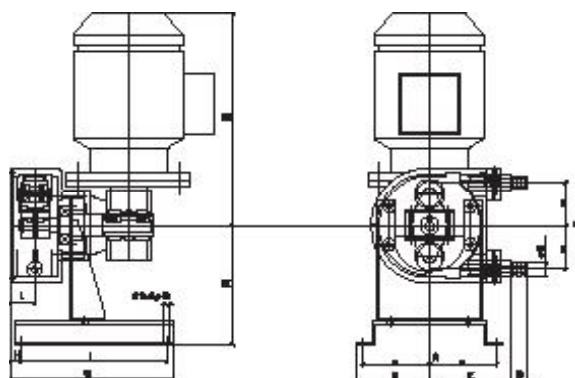

ENCOMBREMENT

TYPE	A	B	C	D	E	F	G	H	I	L	M	N	øO	Kg.
AS 10 FX	172	92	92	20	15	104	185	12	166	28	137	245	7	9
AS 15 FX	172	92	110	20	20	127	183	12	166	30	137	245	7	10
AS 20 FX	210	112	142	35	25	175	248	18	220	40	184	260	7	18
AS 25 FX	250	146	210	45	32	254	386	81	290	52	228	370	11	40

CARACTÉRISTIQUES TECHNIQUES

TYPE	Q (L/H)	A	P	RPM	I	KW	di	Qu	Nm
AS 10 FX	23	4	15	23	60	0,18	9	0,017	6
	35	4	15	35	40	0,18			
	47	4	15	47	30	0,18			
	70	4	15	70	20	0,18			
	93	4	15	93	15	0,18			
AS 15 FX	56	4	15	23	60	0,18	13	0,041	12
	86	4	15	35	40	0,18			
	115	4	15	47	30	0,18			
	172	4	15	70	20	0,18			
	228	4	15	93	15	0,18			
AS 20 FX	149	5	* 15 - 40	23	60	0,18	17	0,108	20
	227	5	* 15 - 40	35	40	0,18			
	305	5	* 15 - 30	47	30	0,18			
	453	5	* 15 - 30	70	20	0,18			
	602	5	* 10 - 20	93	15	0,18			
AS 25 FX	538	6	* 20 - 40	28	60	0,37	25	0,320	30
	672	6	* 20 - 40	35	40	0,37			
	902	6	* 20 - 30	47	30	0,37			
	1344	6	* 20 - 30	70	20	0,75			
	1785	6	* 15 - 25	93	15	0,75			

MOTEUR 3 PH - 230 VOLTS/400 HZ 50 R.P.M. 1400 IP55

*= selon le composé de tuyau

A = Pression d'aspiration en m
 P = Pression de refoulement en m
 I = Ratio

di = Diam. Intérieur de Tuyau en mm
 Qu = Litres par tour
 Nm = Min. couple de démarrage



DISPONIBLE LA CERTIFICATION ATEX:
 EX: I M2 & II 2G & II B, TX

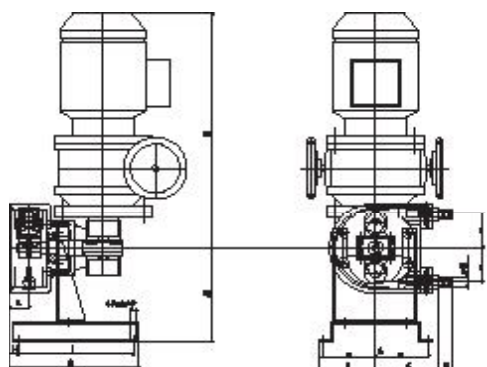

ENCOMBREMENT

TYPE	A	B	C	D	E	F	G	H	I	L	M	N	øO	Kg.
AS 10 VX	172	92	92	20	15	104	185	12	166	28	137	328	7	12
AS 15 VX	172	92	110	20	20	127	183	12	166	30	137	328	7	13
AS 20 VX	210	112	142	35	25	175	248	18	220	40	184	343	7	22
AS 25 VX	250	146	210	45	32	254	386	81	290	52	228	476	11	45

CARACTÉRISTIQUES TECHNIQUES

TYPE	Q (L/H)	A	P	RPM	I	KW	di	Qu	Nm
AS 10 VX	3,2 ÷ 15	4	15	3,2 ÷ 15	60	0,22			
	4,7 ÷ 22,5	4	15	4,7 ÷ 22,5	40	0,22			
	6,3 ÷ 30	4	15	6,3 ÷ 30	30	0,22	9	0,017	6
	9,5 ÷ 45	4	15	9,5 ÷ 45	20	0,22			
	19 ÷ 90	4	15	19 ÷ 90	10	0,22			
AS 15 VX	7,8 ÷ 37	4	15	3,2 ÷ 15	60	0,22			
	11,6 ÷ 55	4	15	4,7 ÷ 22,5	40	0,22			
	15,5 ÷ 73,8	4	15	6,3 ÷ 30	30	0,22	13	0,041	12
	23,4 ÷ 110	4	15	9,5 ÷ 45	20	0,22			
	47 ÷ 221	4	15	19 ÷ 90	10	0,22			
AS 20 VX	21 ÷ 97	5	* 15 - 40	3,2 ÷ 15	60	0,22			
	30 ÷ 146	5	* 15 - 40	4,7 ÷ 22,5	40	0,22			
	41 ÷ 194	5	* 15 - 40	6,3 ÷ 30	30	0,22	17	0,108	20
	62 ÷ 291	5	* 15 - 40	9,5 ÷ 45	20	0,22			
	82 ÷ 388	5	* 15 - 40	12,7 ÷ 60	15	0,22			
AS 25 VX	73 ÷ 365	6	* 20 - 40	3,8 ÷ 19	60	0,37			
	90 ÷ 455	6	* 20 - 40	4,7 ÷ 23,7	40	0,37			
	121 ÷ 608	6	* 20 - 35	6,3 ÷ 31,7	30	0,37	25	0,320	30
	182 ÷ 912	6	* 15 - 30	9,5 ÷ 47,5	20	0,37			
	243 ÷ 1280	6	* 15 - 25	12,7 ÷ 66,7	15	0,75			

MOTEUR 3 PH - 230 VOLTS/400 HZ 50 R.P.M. 1400 IP55

* = selon le composé de tuyau

A = Pression d'aspiration en m
 P = Pression de refoulement en m
 I = Ratio

di = Diam. Intérieur de Tuyau en mm
 Qu = Litres par tour
 Nm = Min. couple de démarrage

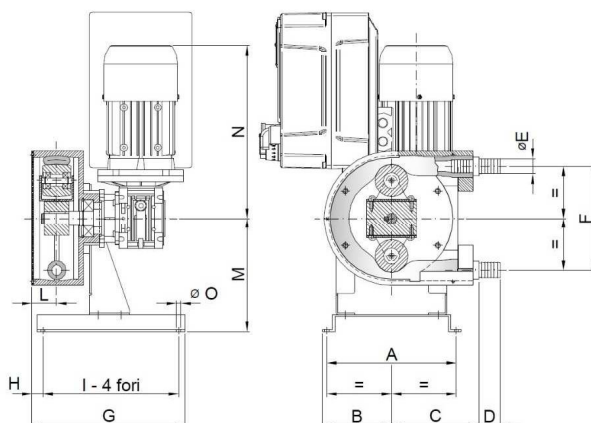

ENCOMBREMENT

TYPE	A	B	C	D	E	F	G	H	I	L	M	N	øO	Kg.
AS 10 IX	172	92	92	20	15	104	185	12	166	28	137	245	7	9
AS 15 IX	172	92	110	20	20	127	183	12	166	30	137	245	7	10
AS 20 IX	210	112	142	35	25	175	248	18	220	40	184	260	7	18
AS 25 IX	250	146	210	45	32	254	386	81	290	52	228	370	11	40

CARACTÉRISTIQUES TECHNIQUES

TYPE	Q (L/H)	A	P	RPM	I	KW	di	Qu	Nm
AS 10 IX	1,5 ÷ 47	4	15	1,5 ÷ 47	60	0,18	9	0,017	6
	3 ÷ 93	4	15	3 ÷ 93	30	0,18			
	6 ÷ 185	4	10	6 ÷ 185	15	0,18			
AS 15 IX	3,7 ÷ 115	4	15	1,5 ÷ 47	60	0,18	13	0,041	12
	7 ÷ 172	4	15	2,8 ÷ 70	40	0,18			
	15 ÷ 345	4	15	6 ÷ 140	30	0,18			
AS 20 IX	10 ÷ 304	5	* 15 - 40	1,5 ÷ 47	60	0,18	17	0,108	20
	18 ÷ 453	5	* 15 - 40	2,8 ÷ 70	40	0,18			
	20 ÷ 602	5	* 15 - 30	3 ÷ 93	30	0,18			
AS 25 IX	29 ÷ 902	6	* 20 - 40	1,5 ÷ 47	60	0,37	25	0,320	30
	54 ÷ 1344	6	* 20 - 40	2,8 ÷ 70	40	0,55			
	58 ÷ 1785	6	* 15 - 25	3 ÷ 93	30	0,75			

MOTEUR 3 PH - 230 VOLTS/400 HZ 50 R.P.M. 1400 IP55

*= selon le composé de tuyau

SIGNAL SUR DEMANDE 4-20mA

A = Pression d'aspiration en m
 P = Pression de refoulement en m
 I = Ratio

di = Diam. Intérieur de Tuyau en mm
 Qu = Litres par tour
 Nm = Min. couple de démarrage

COURBES DE PERFORMANCE

Débit / Sortie

AS 10

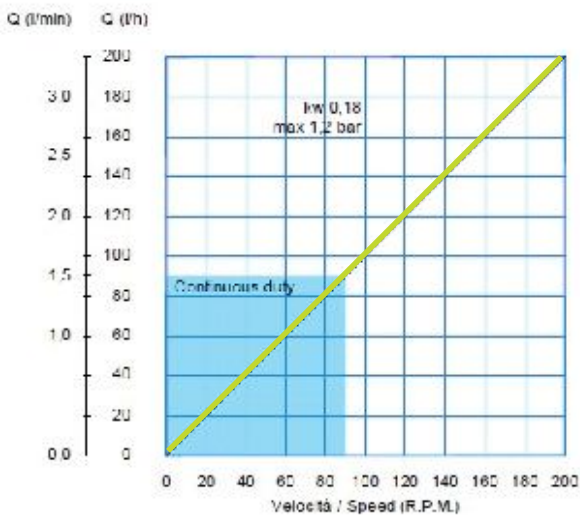

Débit / Sortie

AS 15

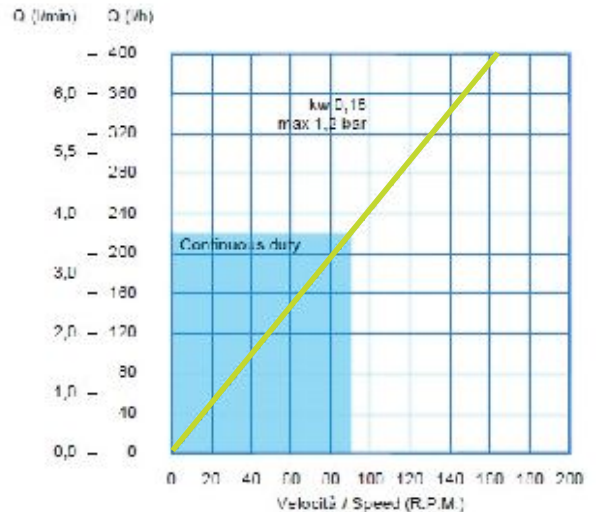

Débit / Sortie

AS 20

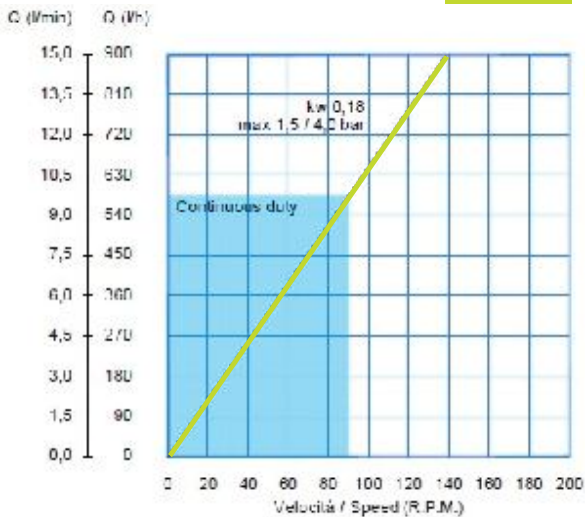

Débit / Sortie

AS 25

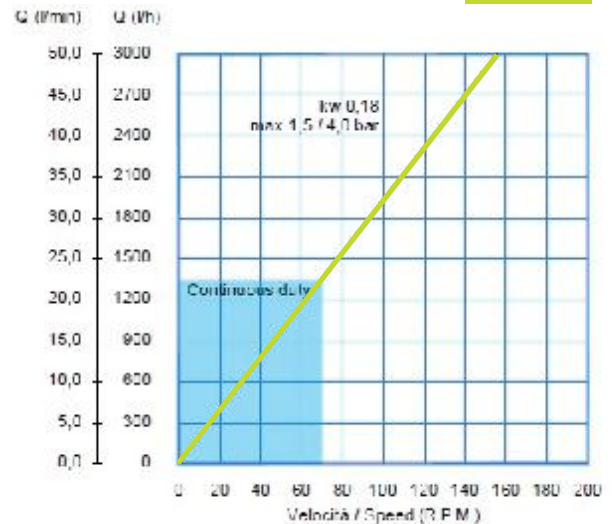

VERSION SPÉCIALE



DOUBLE TÊTE



TÊTE
DE LA POMPE

UTILISATION DES COURBES

- Le débit requis indique la vitesse de la pompe
- Pression de décharge calculée
- Puissance nette du moteur requise
- Température du fluide
- Vitesse maximale de la pompe requise

Les données de fonctionnement décrites ici se réfèrent à l'eau ou à un fluide de particularité similaire



HELIOS ASP

Pompes de dosage péristaltiques

Capacité jusqu'à environ 25000 l/h- tête de sortie de la pompe jusqu'à 10 bars

Viscosité jusqu'à 60000cps - Aspiration possible jusqu'à 8mts

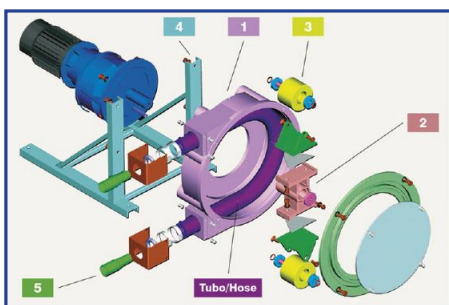

Elément	Matériaux
1 Corps de la pompe	Alliage d'aluminium
2 Rotor	Alliage d'aluminium
3 Rouleaux	Aluminium Nylatron
4 Base	Fer
5 Raccord de tuyau	AISI 304

Couplage spécial:

Raccord de tuyau en AISI 316, PVC, PTFE

DIN

TRI-CLAMPS

ANSI, ISO, UNI, BRIDES

CARACTÉRISTIQUES TECHNIQUES

- Absence de joint mécanique et de boîte à garniture
- Robuste
- Adapte aux fluides agressifs et visqueux
- Fonctionnement à sec continue sans dommages
- Pressions de sortie jusqu'à 10 bars
- Entretien très facile

MATÉRIAUX DE TUYAUX DISPONIBLES:

- NR
- NBR
- EPDM
- NBR pour l'alimentaire
- NR pour l'alimentaire
- Hypalon
- EPDM pour l'alimentaire



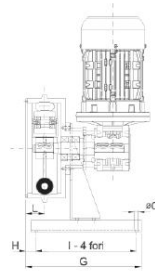

ASP 10/15

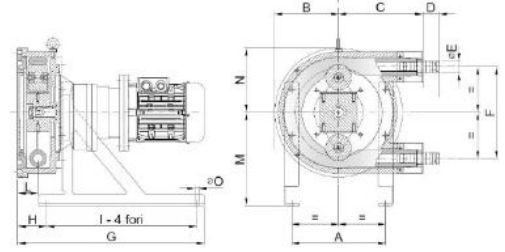
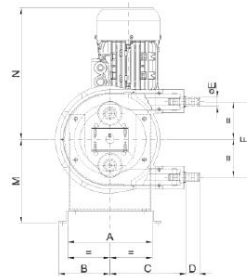

ASP 25/15 - 25 - 32 - 40 - 50 - 65

ENCOMBREMENT

TYPE	A	B	C	D	E	F	G	H	I	L	M	N	øO	Kg.
ASP 10 FX	210	112	166	25	15	167	251	21	220	40	184	260	7	16
ASP 15 FX	210	112	166	30	20	167	251	21	220	40	184	260	7	16
ASP 25/15 FX	250	170	224	25	20	240	495	75	400	52	228	170	11	44
ASP 25 FX	250	170	224	25	32	240	495	75	400	52	228	170	11	44
ASP 32 FX	330	217	230	66	40	314	655	114	520	68	300	217	11	80
ASP 40 FX	420	270	340	70	50	398	735	130	580	74	370	270	14	120
ASP 50 FX	420	330	380	80	65	512	833	158	650	88	440	330	14	160
ASP 65 FX	566	440	510	91	80	672	1107	142	930	106	570	440	17	430

CARACTÉRISTIQUES TECHNIQUES

TYPE	Q (L/H)	A	P	RPM	I	KW	di	Qu	Nm
ASP 10 FX	47	8	100	23	60	0,18	10	0,034	35
	72	8	80	35	40	0,18			
	96	8	80	47	30	0,37			
	143	8	80	70	20	0,37			
ASP 15 FX	102	8	100	23	60	0,18	15	0,074	35
	155	8	80	35	40	0,18			
	209	8	80	47	30	0,37			
	310	8	80	70	20	0,37			
ASP 25/15 FX	275	8	80	35	40	0,55	15	0,131	40
	354	8	80	45	31,5	0,75			
	440	8	70	56	25	0,75			
	550	8	60	70	20	0,75			
ASP 25 FX	672	8	80	35	40	0,55	25	0,32	40
	864	8	80	45	31,5	0,75			
	1075	8	70	56	25	0,75			
	1344	8	60	70	20	0,75			
ASP 32 FX	1596	8	100	38	37	1,1	32	0,70	75
	1974	8	80	47	30	1,1			
	2436	8	60	58	24	1,1			
	2940	8	40	70	20	1,1			
ASP 40 FX	2040	8	100	25	56	1,5	40	1,36	110
	2938	8	80	36	39	1,5			
	3672	8	60	45	31,5	1,5			
	5712	8	40	70	20	1,5			
ASP 50 FX	4185	8	100	25	56	2,2	50	2,79	200
	6026	8	60	36	39	2,2			
	7533	8	60	45	31,5	3			
	11718	8	40	70	20	3			
ASP 65 FX	8580	8	80	22	63	4	65	6,50	400
	13650	8	60	35	40	5,5			
	15500	8	60	45	31,5	7,5			
	21840	8	50	56	25	7,5			

MOTEUR 3 PH - 230 VOLTS/400 HZ 50 R.P.M. 1400 IP55

*= selon le composé de tuyau

A = Pression d'aspiration en m

di = Diam. Intérieur de Tuyau en mm

P = Pression de refoulement en m

Qu = Litres par tour

I = Ratio

Nm = Min. couple de démarrage



DISPONIBLE LA CERTIFICATION ATEX:
EX: I M2 & II 2G & II B, TX

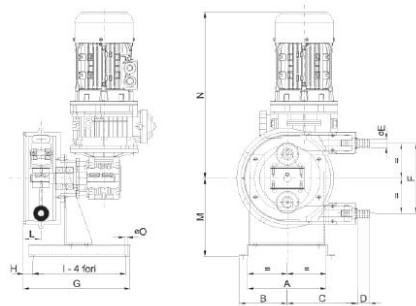

ASP 10/15

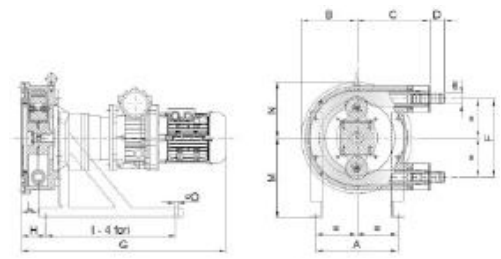

ASP 25/15 - 25 - 32 - 40 - 50 - 65

ENCOMBREMENT

TYPE	A	B	C	D	E	F	G	H	I	L	M	N	øO	Kg.
ASP 10 VX	210	112	166	25	15	167	251	21	220	40	184	345	7	20
ASP 15 VX	210	112	166	30	20	167	251	21	220	40	184	345	7	20
ASP 25/15 VX	250	170	224	45	20	240	640	75	400	52	228	170	11	50
ASP 25 VX	250	170	224	45	32	240	640	75	400	52	228	170	11	50
ASP 32 VX	330	217	290	66	40	314	735	114	520	68	300	217	11	90
ASP 40 VX	420	270	340	70	50	398	884	130	580	74	370	270	14	120
ASP 50 VX	420	330	380	80	65	512	1017	158	650	88	440	330	14	180
ASP 65 VX	566	440	510	91	80	672	1385	142	930	106	570	440	18	430

CARACTÉRISTIQUES TECHNIQUES

TYPE	Q (L/H)	A	P	RPM	I	KW	di	Qu	Nm
ASP 10 VX	6,5÷30,6	8	100/80	3,2÷15	60	0,22	10	0,034	35
	9,6÷46	8	100/70	4,7÷22,5	40	0,22			
	15,5÷77,5	8	100/60	7,6÷38	25	0,37			
	26÷129	8	100/50	12,7÷63,3	15	0,37			
ASP 15 VX	14,2÷66,6	8	100/80	3,2÷15	60	0,22	15	0,074	35
	21÷100	8	100/70	4,7÷22,5	40	0,22			
	34÷168,7	8	100/60	7,6÷38	25	0,37			
	56,4÷281	8	100/50	12,7÷63,3	15	0,37			
ASP 25/15 VX	37÷196,5	8	100/60	4,7÷25	40	0,55	15	0,131	40
	60÷314,4	8	100/70	7,6÷40	25	0,75			
	94,3÷487,3	8	100/50	12÷62	16	0,75			
	118÷629	8	100/40	15÷80	12,5	0,75			
ASP 25 VX	90÷480	8	100/60	4,7÷25	40	0,55	25	0,32	40
	146÷768	8	100/60	7,6÷40	25	0,75			
	230÷1190	8	100/50	12÷62	16	0,75			
	288÷1536	8	100/40	15÷80	12,5	0,75			
ASP 32 VX	210÷1134	8	100/60	5÷27	37	1,1	32	0,70	75
	319÷1680	8	100/60	7,6÷40	25	1,1			
	504÷2604	8	100/50	12÷62	16	1,1			
	630÷3360	8	100/40	15÷80	12,5	1,1			
ASP 40 VX	342÷1811	8	100/60	4,2÷22,2	45	1,5	40	1,36	110
	489÷2611	8	100/60	6÷32	31,5	1,5			
	775÷4080	8	100/50	9,5÷50	20	2,2			
	979÷5059	8	100/40	12÷62	16	2,2			
ASP 50 VX	703÷3716	8	100/60	4,2÷22,2	45	2,2	50	2,79	200
	1004÷5356	8	100/60	6÷32	31,5	2,2			
	1590÷8370	8	100/50	9,5÷50	20	3			
	2008÷10378	8	100/40	12÷62	16	3			
ASP 65 VX	1638÷8658	8	100/60	4,2÷22,2	45	4	65	6,50	400
	2340÷12480	8	100/60	6÷32	31,5	5,5			
	2964÷15600	8	100/50	7,6÷40	25	7,5			
	3705÷19500	8	100/40	9,5÷50	20	7,5			

MOTEUR 3 PH - 230 VOLTS/400 HZ 50 R.P.M. 1400 IP55

*= selon le composé de tuyau

A = Pression d'aspiration en m

di = Diam. Intérieur de Tuyau en mm

P = Pression de refoulement en m

Qu = Litres par tour

I = Ratio

Nm = Min. couple de démarrage



DISPONIBLE LA CERTIFICATION ATEX:
EX: I M2 & II 2G & IIB, TX



ASP 10/15

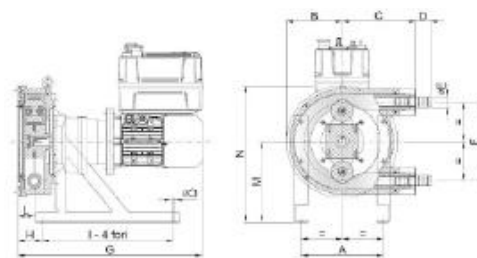
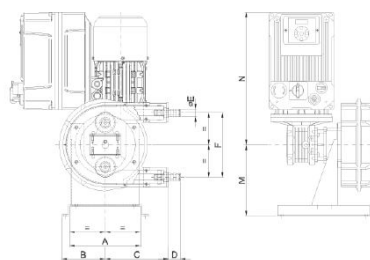

ASP 25/15 - 25 - 32 - 40 - 50 - 65

ENCOMBREMENT

TYPE	A	B	C	D	E	F	G	H	I	L	M	N	ØO	Kg.
ASP 10 IX	210	112	166	25	15	167	251	21	220	40	184	334	7	25
ASP 15 IX	210	112	166	30	20	167	251	21	220	40	184	334	7	25
ASP 25/15 IX	250	170	224	25	20	240	550	75	400	52	228	398	11	54
ASP 25 IX	250	170	224	25	32	240	550	75	400	52	228	398	11	54
ASP 32 IX	330	217	230	66	40	314	654	114	520	68	300	517	11	90
ASP 40 IX	420	270	340	70	50	398	735	130	580	74	370	640	14	130
ASP 50 IX	420	330	380	80	65	512	833	158	650	88	440	770	14	170
ASP 65 IX	566	440	510	91	80	672	1107	142	930	106	570	1010	18	430

CARACTÉRISTIQUES TECHNIQUES

TYPE	Q (L/H)	A	P	RPM	I	KW	di	Qu	Nm
ASP 10 IX	9÷65	8	100/80	4,5÷32	60	0,25	10	0,034	35
	19÷130	8	100/60	9,3÷65	40	0,37			
	28,5÷200	8	100/50	14÷98	20	0,37			
ASP 15 IX	20÷142	8	100/80	4,5÷32	60	0,25	15	0,074	35
	41,3÷289	8	100/60	9,3÷65	30	0,37			
	62÷435	8	100/50	14÷98	20	0,37			
ASP 25/15 IX	55÷385	8	100/80	7÷49	40	0,75	15	0,131	40
	71÷495	8	100/60	9÷63	31,5	0,75			
	110÷870	8	100/50	14÷98	20	0,75			
ASP 25 IX	134÷940	8	100/80	7÷49	40	0,75	25	0,32	40
	173÷1210	8	100/60	9÷63	31,5	0,75			
	268÷1880	8	100/50	14÷98	20	0,75			
ASP 32 IX	294÷2058	8	100/80	7÷49	46	1,5	32	0,70	75
	390÷2730	8	100/50	9,3÷65	30	1,5			
	588÷4116	8	100/40	14÷98	20	1,5			
ASP 40 IX	408÷2856	8	100/80	5÷35	56	1,5	40	1,36	110
	734÷5140	8	100/50	9÷63	31,5	2,2			
	938÷6528	8	100/40	11,5÷80	24,5	2,2			
ASP 50 IX	837÷5860	8	100/80	5÷35	56	2,2	50	2,79	200
	1507÷10546	8	100/50	9÷63	31,5	3			
	1925÷13395	8	100/40	11,5÷80	24,5	4			
ASP 65 IX	1720÷12090	8	100/80	4,4÷31	63	7,5	65	6,50	400
	2730÷19110	8	100/50	7÷49	40	7,5			
	3510÷24570	8	100/40	9÷63	31,5	7,5			

MOTEUR 3 PH - 230 VOLTS/400 HZ 50 R.P.M. 1400 IP55

*= selon le composé de tuyau

SIGNAL SUR DEMANDE 4-20mA

A = Pression d'aspiration en m
P = Pression de refoulement en m
I = Ratio

di = Diam. Intérieur de Tuyau en mm
Qu = Litres par tour
Nm = Min. couple de démarrage

COURBES DE PERFORMANCE

ASP 10

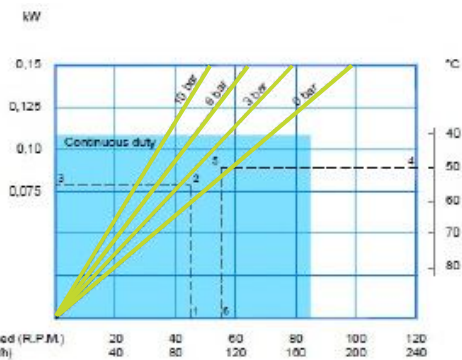

ASP 15

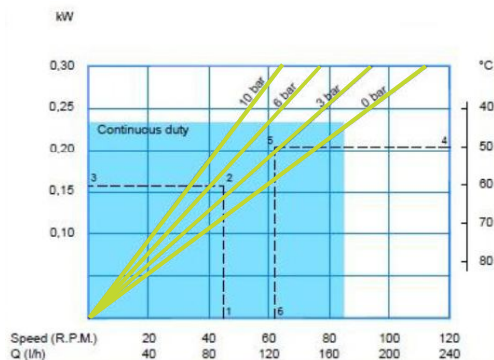

ASP 25/15

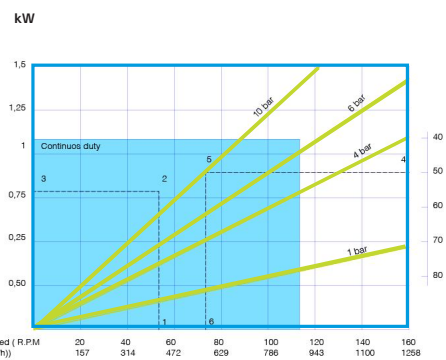

ASP 25

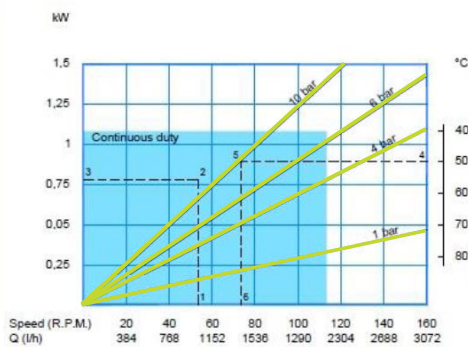

ASP 32

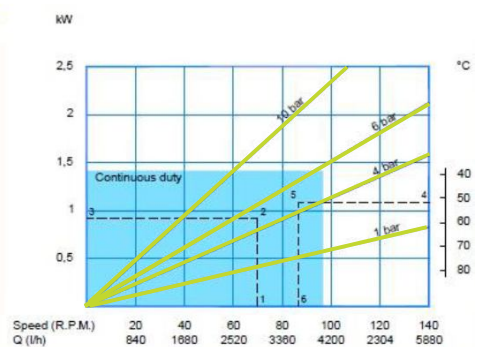

ASP 40

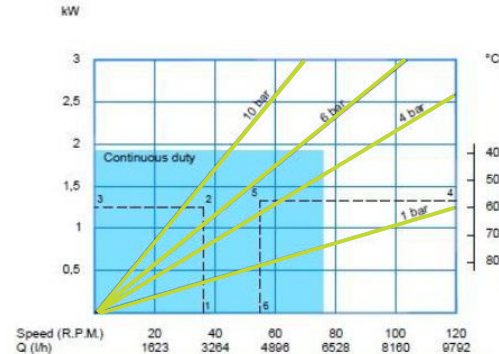

ASP 50

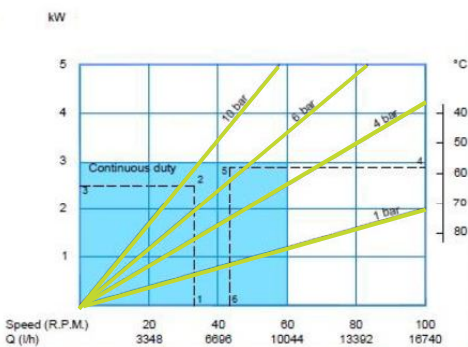

ASP 65

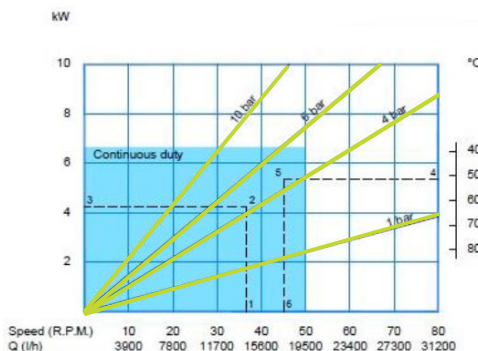

UTILISATION DES COURBES

- Le débit requis indique la vitesse de la pompe
- Pression de décharge calculée
- Puissance nette du moteur requise
- Température du fluide
- Vitesse maximale de la pompe requise

Les données de fonctionnement décrites ici se réfèrent à l'eau ou à un fluide de particularité similaire

VERSION SPÉCIALE



DOUBLE TÊTE



TÊTE DE LA POMPE



CHARIOT



HELIOS ATR

Pompes de dosage péristaltiques
 Capacité jusqu'à environ 64000 l/h- tête de sortie de la pompe jusqu'à 8 bars
 Viscosité jusqu'à 60000cps - Aspiration possible jusqu'à 8mts

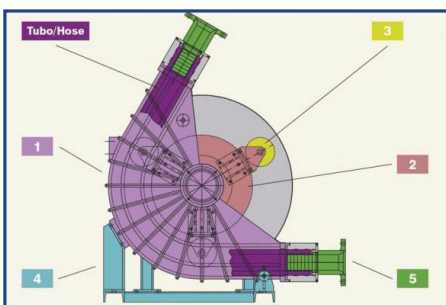

Élément	Matériaux
1 Corps de la pompe	Fonte
2 Rotor	Fer
3 Rouleaux	Aluminium Nylatron
4 Base	Fer
5 Brides ISO	AISI 304

Couplage spécial:
 DIN
 TRI-CLAMPS
 ANSI, ISO, UNI, BRIDES

CARACTÉRISTIQUES TECHNIQUES

- Absence de joint mécanique et de boîte à garniture
- Robuste
- Adapte aux fluides agressifs et visqueux
- Fonctionnement à sec continue sans dommages
- Pressions de sortie jusqu'à 8 bars
- Entretien très facile
- Grande prestation

MATÉRIAUX DE TUYAUX DISPONIBLES

- NR
- NBR
- EPDM
- NR pour l'alimentaire
- Hypalon

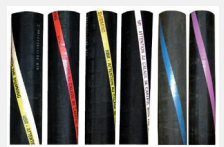

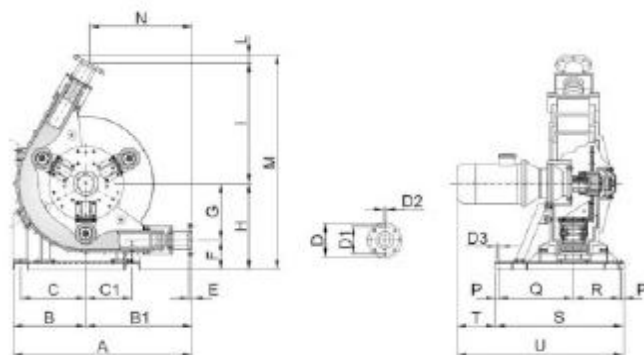

ATR 80 FX/TD

ENCOMBREMENT

A	B	B1	C	C1	D	D1	D2	D3	E	F	G	H	I	L	M	N	O	P	Q	R	S	T	U
1148	467	681	417	295	220	180	16	18	22	189	365	554	772	55	1391	657	O	20	480	300	820	245	1065

CARACTÉRISTIQUES TECHNIQUES

Q(L/H)	A	P	RPM	Kw	di	Qu	Nm	Kg
12160	8	50 (80)	22,3	5,5 (7,5)				
18874	8	30 (50)	34,6	5,5 (9)	80	9,1	1200	390
21915	8	25 (45)	40,1	5,5 (9)				
26422	8	20 (40)	48,4	7,5 (11)				

ATR 280 FX/TD

ENCOMBREMENT

A	B	B1	C	C1	D	D1	D2	D3	E	F	G	H	I	L	M	N	O	P	Q	R	S	T	U
1148	467	681	417	295	220	180	16	18	22	189	365	554	772	55	1391	657	119	20	550	370	960	294	1254

CARACTÉRISTIQUES TECHNIQUES

Q(L/H)	A	P	RPM	Kw	di	Qu	Nm	Kg
24321	8	50 (80)	22,2	7,5 (11)				
37748	8	30 (50)	34,6	11 (15)	80	18,2	2000	515
43830	8	25 (45)	40,1	11 (15)				
52845	8	20 (40)	48,4	11 (15)				

MOTEUR 3 PH - 230 VOLTS/400 HZ 50 R.P.M. 1400 IP55

* = selon le composé de tuyau

A = Pression d'aspiration en m

P = Pression de refoulement en m

di = Diam. Intérieur de Tuyau en mm

Qu = Litres par tour

Nm = Min. couple de démarrage



DISPONIBLE LA CERTIFICATION ATEX:

EX: I M2 & II 2G & II B, TX

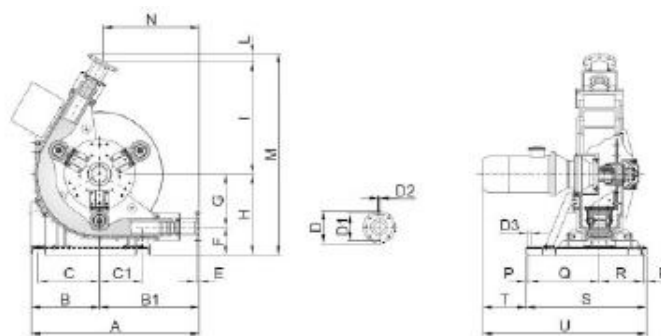

ATR 80 IX/TD

ENCOMBREMENT

A	B	B1	C	C1	D	D1	D2	D3	E	F	G	H	I	L	M	N	O	P	Q	R	S	T	U
1148	467	681	417	295	220	180	16	18	22	189	365	554	772	55	1381	657	O	20	480	300	820	245	1065

CARACTÉRISTIQUES TECHNIQUES

Q(L/H)	A	P	RPM	Kw	hz	di	Qu	Nm	Kg
2432 ÷ 14592	8	50 (80)	4,5 ÷ 26,7	5,5 (7,5)					
3775 ÷ 22649	8	30 (50)	6,9 ÷ 41,5	5,5 (9)	10 ÷ 60	80	9,1	1200	440
4383 ÷ 26298	8	25 (45)	8,0 ÷ 48,2	7,5 (11)					
5284 ÷ 31707	8	20 (40)	9,7 ÷ 58,1	7,5 (11)					

ATR 280 IX/TD

ENCOMBREMENT

A	B	B1	C	C1	D	D1	D2	D3	E	F	G	H	I	L	M	N	O	P	Q	R	S	T	U
1148	467	681	417	295	220	180	16	18	22	189	365	554	772	55	1381	657	119	20	550	370	960	294	1254

CARACTÉRISTIQUES TECHNIQUES

Q(L/H)	A	P	RPM	Kw	hz	di	Qu	Nm	Kg
4864 ÷ 29185	8	50 (80)	4,5 ÷ 26,7	11 (15)					
7550 ÷ 45298	8	30 (50)	6,9 ÷ 41,5	11 (15)	10 ÷ 60	80	18,2	2000	580
8766 ÷ 52596	8	25 (45)	8,0 ÷ 48,2	11 (15)					
10569 ÷ 63414	8	20 (40)	9,7 ÷ 58,1	11 (15)					

MOTEUR 3 PH - 230 VOLTS/400 HZ 50 R.P.M. 1400 IP55

SIGNAL SUR DEMANDE 4-20mA

* = selon le composé de tuyau
 A = Pression d'aspiration en m
 P = Pression de refoulement en m

di = Diam. Intérieur de Tuyau en mm
 Qu = Litres par tour
 Nm = Min. couple de démarrage

COURBES DE PERFORMANCE

VERSION SPÉCIALE

Débit / Sortie

ATR 80

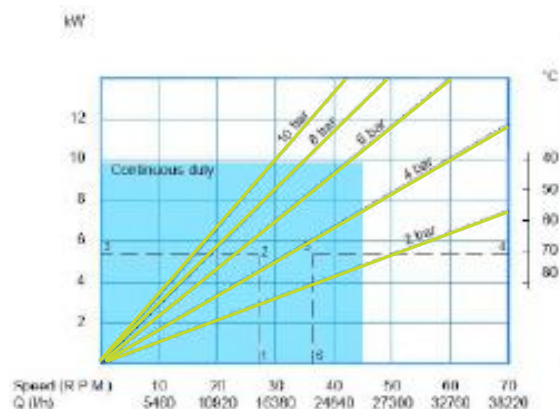

ATR 80/280 TC
TRANSMISSION PAR COURROIE

Débit / Sortie

ATR 280

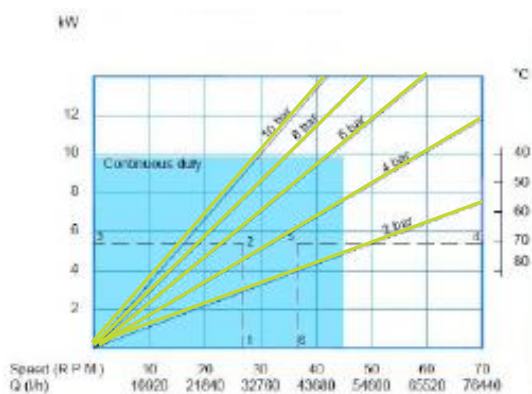

TÊTE DE LA POMPE

UTILISATION DES COURBES

- Le débit requis indique la vitesse de la pompe
- Pression de décharge calculée
- Puissance nette du moteur requise
- Température du fluide
- Vitesse maximale de la pompe requise

Les données de fonctionnement décrites ici se réfèrent à l'eau ou à un fluide de particularité similaire



CHARIOT

fluimac[®]

pump solution



FLUIMAC S.r.l.

Via Brescia 1
21049, Tradate (VA) - Italy
Tel.: +39 0331 866688
Fax: +39 0331 864870

www.fluimac.com
info@fluimac.com

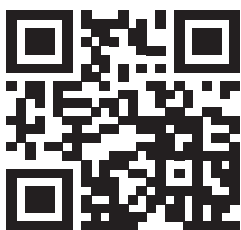

PARTENAIRE AUTORISÉ:

Made in
Italy

