

Speed Control Valve with Adjusting Dial DSC series



SPEED CONTROL VALVE WITH ADJUSTING DIAL DSC SERIES

Visible Flow Rate!

Launch of Long-awaited Compact Type

New



Visible Flow Rate!

Compact type added to dial speed control valve with linear characteristics

Industry's smallest *

Compact type

With the adoption of a compact dial, installation on the speed control valve cylinder is possible without interfering with the cylinder contact surface. (PAT.)

* Based on investigation conducted by CKD in October, 2015



Industry's smallest

More precise quantification realized

Compact type

Needle position is indicated on the dial in increments of 0.5
More precise quantification now possible.

Improved operability with click feeling

The dial clicks every increment of 0.5, allowing changes in value to be gauged even in situations where visual verification is not possible.



Series variation		Tube outer diameter	Port size				
			M5	R1/8	R1/4	R3/8	R1/2
Compact type <i>New</i>	Standard flow type DSC-C-**-*	φ3.2	●				
	Low-flow type DSC-C-**-*-L	φ4	●	●			
	Ultra-low-flow type DSC-C-**-*-F	φ6	●	●			
Standard type	Low-flow type DSC-**-*-L	φ4		●			
		φ6		●			
	Standard flow type DSC-**-**	φ8		●	●		
		φ10		●	●	●	
		φ12			●	●	

Broad lineup

SPEED CONTROL VALVE WITH ADJUSTING DIAL

DSC series

With flow speed indicator

Flow characteristics proportional to dial value (needle position)

Compact type

Standard type

Optimal needle design delivers linear flow characteristics proportional to dial flow speed, variations in cylinder speed and flow are minimal, and resetting is possible when changing needles simply by setting the dial to the same value. Operator workload has been significantly reduced, allowing adjustment errors to be avoided.

[Flow characteristics]

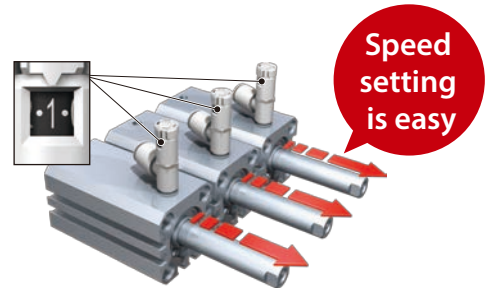
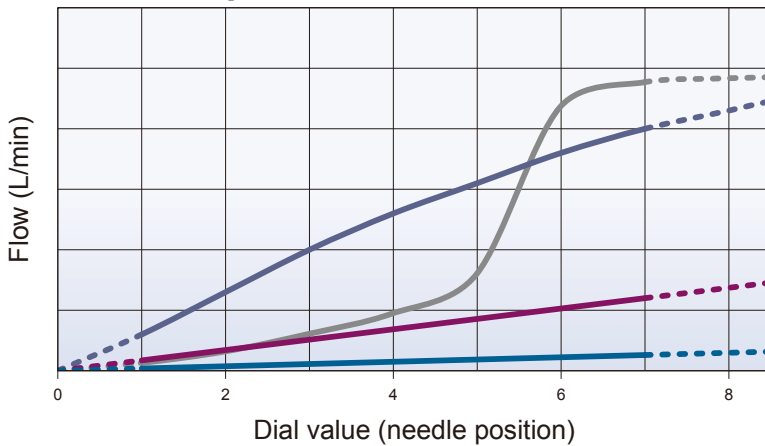

Standard flow type

Low-flow type

Ultra-low-flow type

SC3W (ref.)

Easy adjustment

Compact type

Standard type

A push-lock system has been employed to secure needles. This eliminates needle movement when locking, facilitating secure locking. **Operation is simple, and adjustments can be made easily by anyone.**

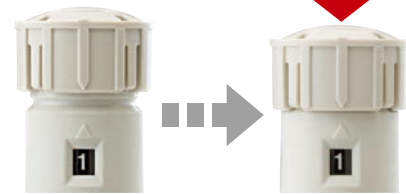

With rotation position mark on adjustment knob

Cylinder speed values can be managed with ease.

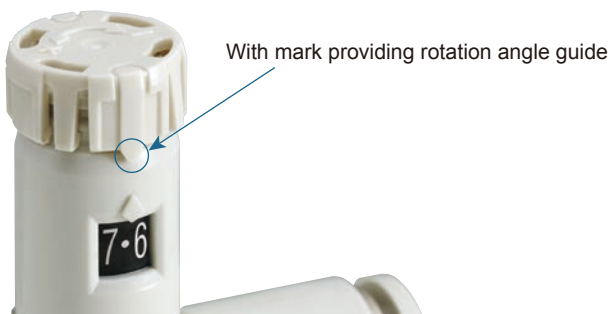

Flow speed can be verified from 2 surfaces

The dial indicator can be visually checked from the front and rear surface.





SPEED CONTROL VALVE WITH ADJUSTING DIAL

DSC Series

- Port size: M5, R1/8 to R1/2

JIS symbol

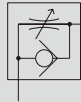

(Meter out)



(Meter in)



Specifications

- Compact type

Descriptions		DSC-C-M5			DSC-C-6		
Applicable tube outer diameter	mm	φ3.2	φ4	φ6	φ4	φ6	φ8
Port size		M5			R1/8		
Working fluid		Compressed air					
Max. working pressure	MPa	1.0					
Min. working pressure	MPa	0.05					
Withstanding pressure	MPa	1.5					
Fluid temperature	°C	5 to 60 (there should be no freezing) (Note 2)					
Ambient temperature	°C	0 to 60 (there should be no freezing)					
Needle control range		1 to 7 rotations					
Weight	g	10.5	11.5	12	22	23	24
Free flow	Flow L/min(ANR)	87	100		210	270	
	Effective sectional area mm ²	1.3	1.5		3.2	4	
Controlled flow (standard flow)	Flow L/min(ANR)	60			160	200	
	Effective sectional area mm ²	0.9			2.4	3	
Controlled flow (low flow)	Flow L/min(ANR)	20			60		
	Effective sectional area mm ²	0.3			0.9		
Controlled flow (ultra-low flow)	Flow L/min(ANR)	-	6.7		13	-	
	Effective sectional area mm ²	-	0.1		0.2	-	

- Standard type

Descriptions		DSC-6			DSC-8			DSC-10				DSC-15	
Applicable tube outer diameter	mm	φ4	φ6	φ8	φ6	φ8	φ10	φ6	φ8	φ10	φ12	φ10	φ12
Port size		R1/8			R1/4			R3/8				R1/2	
Working fluid		Compressed air											
Max. working pressure	MPa	1.0											
Min. working pressure	MPa	0.05											
Withstanding pressure	MPa	1.5											
Fluid temperature	°C	5 to 60 (there should be no freezing) (Note 2)											
Ambient temperature	°C	0 to 60 (there should be no freezing)											
Needle control range		1 to 10 rotations											
Weight	g	33	34	35	45	46	48	60	61	64	65	95	97
Free flow	Flow L/min(ANR)	210	270		470	530		670	1000	1070		1470	1600
	Effective sectional area mm ²	3.2	4		7	8		10	15	16		22	24
Controlled flow (standard flow)	Flow L/min(ANR)	160	200		320	400		400	700	800		1120	1200
	Effective sectional area mm ²	2.4	3		5	6		6	10.5	12		17	17.5
Controlled flow (low flow)	Flow L/min(ANR)	60			130			270				400	
	Effective sectional area mm ²	0.9			2			4				6	

Note 1: The flow is the atmospheric pressure conversion value at 0.5MPa.

Note 2: Freezing could occur by adiabatic expansion depended with air quality (dew point).

Secondary battery specifications

- Design applicable for LiB manufacturing process

DSC - - P4

Clean room specifications

- Dust generation preventing structure for use in cleanrooms

DSC - - P70

How to order

DSC - C - 6 - 6 - I L

A Product size

B Port size

C Applicable tube outer diameter

D Control method

E Flow type

Symbol	Descriptions
A Product size	
Blank	Standard type
-C	Compact type
B Port size	
M5	M5
6	R1/8
8	R1/4
10	R3/8
15	R1/2
C Applicable tube outer diameter	
3	φ3.2
4	φ4
6	φ6
8	φ8
10	φ10
12	φ12
D Control method	
Blank	Meter out
I	Meter in (push ring color: black)
E Flow type	
Blank	Standard flow
L	Low flow
F	Ultra-low flow (compact type only)

Port size, applicable tube outer diameter and flow type combination

Product size	Compact type		Standard type			
	M5	R1/8	R1/8	R1/4	R3/8	R1/2
φ3.2	○					
φ4	◎	◎	○			
φ6	◎	◎	○	○	○	
φ8		○	○	○	○	
φ10				○	○	○
φ12					○	○

○: Flow type "F (ultra-low flow type)" selection not possible

◎: Flow type "F (ultra-low flow type)" selection possible

Flow characteristics

• Compact type

• DSC-C-M5-*

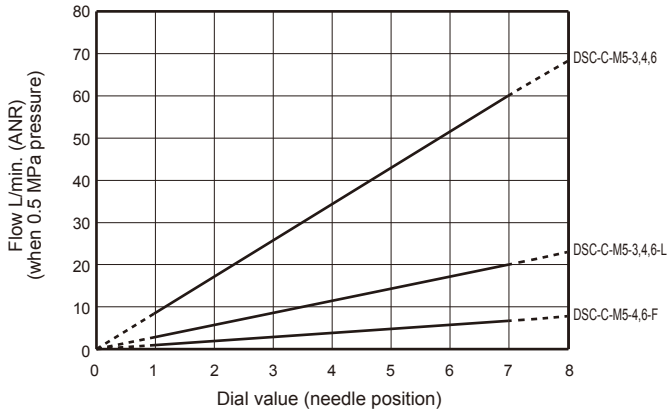

• DSC-C-6-*

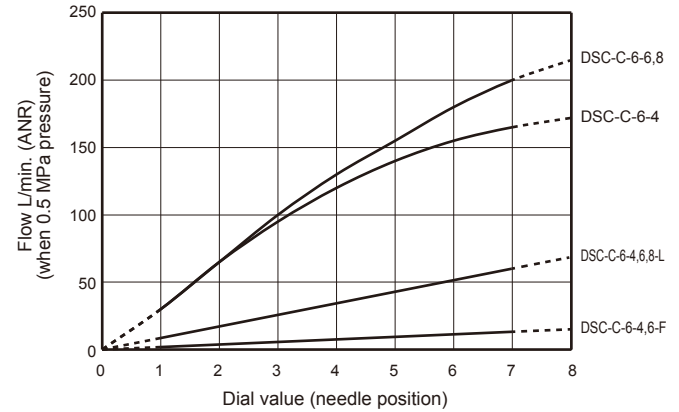

• Standard type

• DSC-6-*

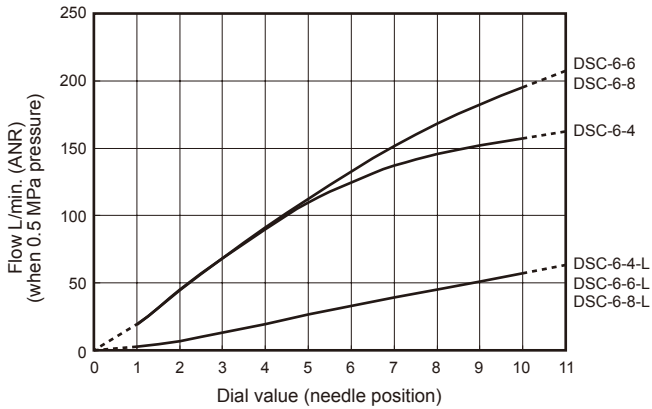

• DSC-8-*

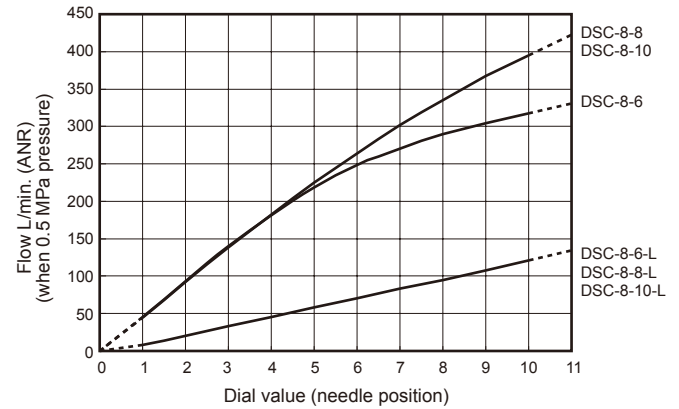

• DSC-10-*

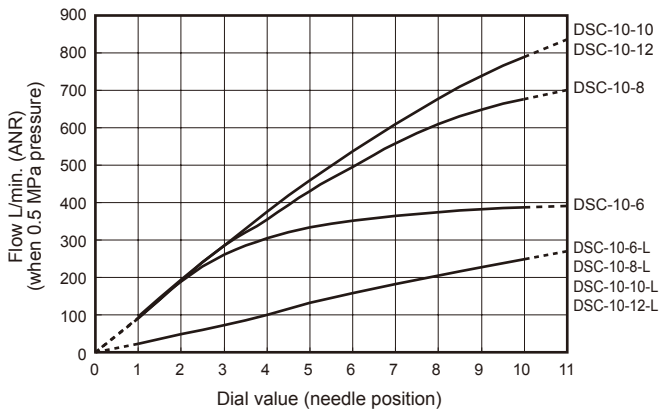

• DSC-15-*

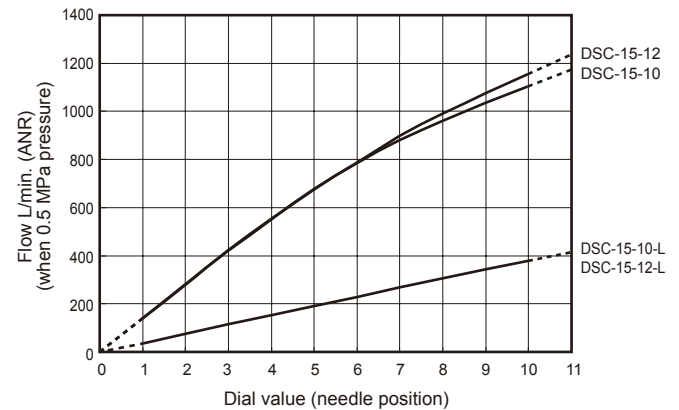

Note: Flow characteristics will vary based on pipe conditions and temperature changes before and after, and therefore caution is advised.

Internal structure and parts list

- Compact type

- DSC-C-M5-4, 6

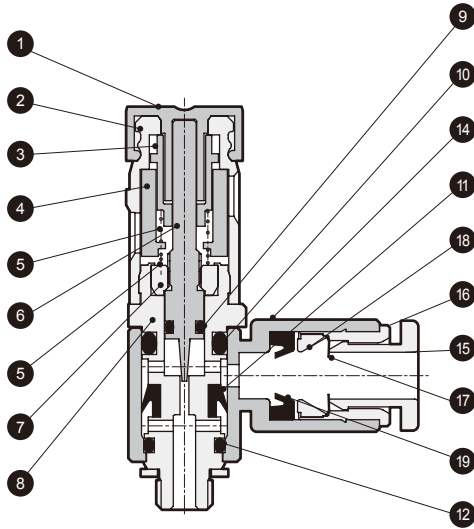

- DSC-C-M5-3

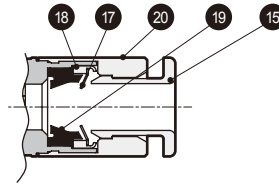

- DSC-C-6-*

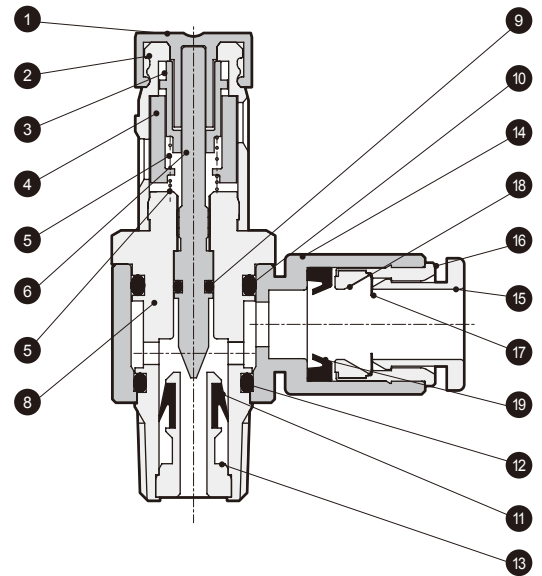

No.	Parts name	Material	No.	Parts name	Material
1	Knob	Polyacetal	11	Packing	Hydrogen nitrile rubber
2	Gear cover	PBT	12	O-ring	Nitrile rubber
3	Slide gear	PBT	13	Tick section	Brass
4	Indication ring	PBT	14	Rotor	PBT
5	Spring	Stainless steel	15	Push ring	PBT
6	Needle	Stainless steel	16	Outer ring	Brass
7	Gland nut	Brass	17	Chuck	Stainless steel
8	Rotary shaft	Brass	18	Chuck holder	Polyetherimide (brass) Note 1
9	O-ring	Nitrile rubber	19	Packing	Nitrile rubber
10	O-ring	Nitrile rubber	20	Joint body	Copper alloy

Note 1: The value in parentheses () indicates that DSC-C-M5-3 is selected.

Note 2: All the brass parts are plated with electroless nickeling.

- Compact type

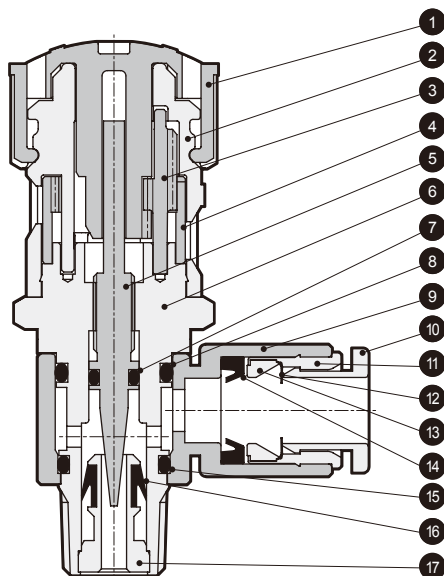

No.	Parts name	Material
1	Knob	Polyacetal
2	Gear cover	PBT
3	Gear	Stainless steel
4	Indication ring	Polyacetal
5	Needle	Stainless steel
6	Rotary shaft	Brass
7	O-ring	Nitrile rubber
8	O-ring	Nitrile rubber
9	Rotor	PBT
10	Push ring	PBT
11	Outer ring	Brass
12	Chuck	Stainless steel
13	Chuck holder	Polyetherimide
14	Packing	Nitrile rubber
15	O-ring	Nitrile rubber
16	Packing	Hydrogen nitrile rubber
17	Tick section	Brass

Note 1: All the brass parts are plated with electroless nickeling.

Dimensions

• Compact type

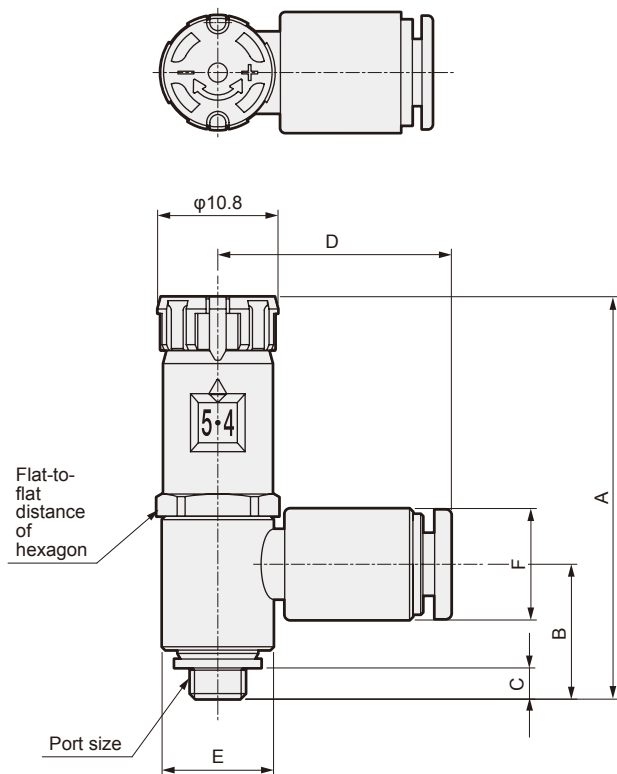

• Standard type

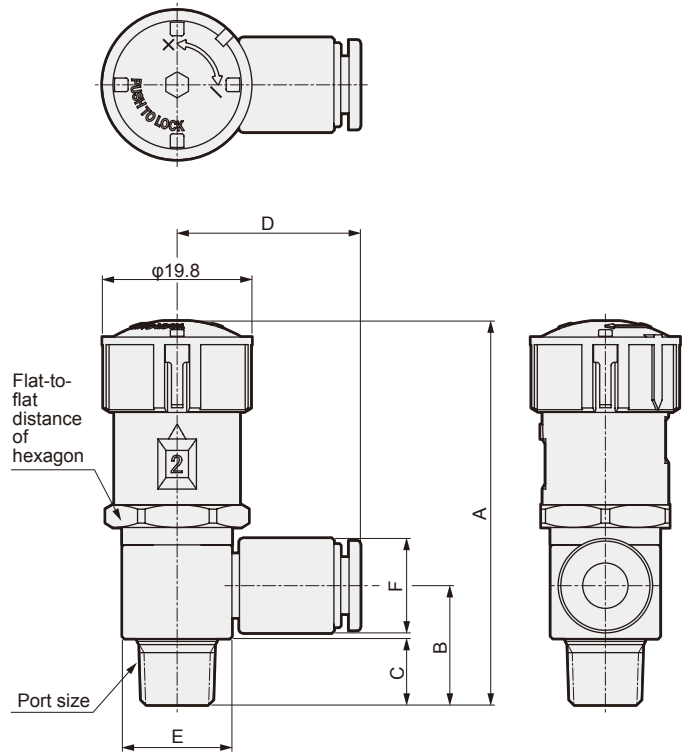

Model no.	Product type	Port size	Applicable tube outer diameter	A		B	C	D	E	F	Flat-to-flat distance of hexagon
				When locked	When adjusting						
DSC-C-M5-3	Compact type	M5×0.8	φ3.2	36	37.5	11.9	3	16.5	10	7.5	10
DSC-C-M5-4			φ4			11.9		21		10	
DSC-C-M5-6			φ6			11.7		22.5		12.5	
DSC-C-6-4		R1/8	φ4	41.9	43.4	16.2	8.7	23.5	14.5	10	13
DSC-C-6-6			φ6			15.7		24.5		12.5	
DSC-C-6-8			φ8			15.4		26		14.5	
DSC-6-4	Standard type	R1/8	φ4	51	54	16.2	8.7	23.5	14.5	10	17
DSC-6-6			φ6			15.7		24.5		12.5	
DSC-6-8			φ8			15.4		26		14.5	
DSC-8-6		R1/4	φ6	55.5	58.5	20	11.7	26	18	12.5	17
DSC-8-8			φ8			19		27.5		14.5	
DSC-8-10			φ10			19		30.5		17.5	
DSC-10-6	R3/8	φ6	58	61	23.1	12.7	28.5	22.5	12.5	19	
DSC-10-8		φ8			21.3		30		14.5		
DSC-10-10		φ10			21.8		32		17.5		
DSC-10-12		φ12			21.7		33.5		20		
DSC-15-10	R1/2	φ10	63	66	25.2	15.7	34.5	27.5	17.5	24	
DSC-15-12		φ12			25.7		36		20		



Safety precautions

Always read this section before starting use.

When designing and manufacturing a device using CKD products, the manufacturer is obligated to check that device safety mechanical mechanism, pneumatic control circuit, or water control circuit and the system operated by electrical control that controls the devices is secured.

It is important to select, use, handle, and maintain the product appropriately to ensure that the CKD product is used safely. Observe warnings and precautions to ensure device safety.

Check that device safety is ensured, and manufacture a safe device.

WARNING

1 This product is designed and manufactured as a general industrial machine part. It must be handled by an operator having sufficient knowledge and experience in handling.

2 Use this product in accordance with specifications.

This product must be used within its stated specifications. It must not be modified or machined.

This product is intended for use as a general-purpose device for industrial machine or parts. It is not intended for use outdoors (not applied for outdoor specification products) or for use under the following conditions or environment.

(If you consult CKD upon adoption and consent to CKD product specifications, it will be applicable; however, safeguards should be adopted to circumvent dangers in the event of failure.)

① Use for special applications requiring safety including nuclear energy, railroad, aviation, ship, vehicle, medical equipment, equipment, or applications coming into contact with beverage or food, amusement equipment, emergency shutoff circuits, press machine, brake circuits, or for safeguard.

② Use for applications where life or assets could be adversely affected, and special safety measures are required.

3 Observe corporate standards and regulations, etc., related to the safety of device design and control, etc.

ISO 4414, JIS B 8370 (pneumatic system rules)

JFPS2008 (Principles for pneumatic cylinder selection and use)

Including High Pressure Gas Maintenance Law, Occupational Safety and Sanitation Laws, other safety rules, body standards and regulations, etc.

4 Do not handle, pipe, or remove devices before confirming safety.

① Inspect and service the machine and devices after confirming safety of the entire system related to this product.

② Note that there may be hot or charged sections even after operation is stopped.

③ When inspecting or servicing the device, turn off the energy source (air supply or water supply), and turn off power to the facility. Discharge any compressed air from the system, and pay enough attention to possible water leakage and leakage of electricity.

④ When starting or restarting a machine or device that incorporates pneumatic components, make sure that the system safety, such as pop-out prevention measures, is secured.

5 Observe warnings and cautions on the pages below to prevent accidents.

■ The safety cautions are ranked as DANGER, WARNING and CAUTION in this section.

 **DANGER:** When a dangerous situation may occur if handling is mistaken leading to fatal or serious injuries, or when there is a high degree of emergency to a warning.

 **WARNING:** When a dangerous situation may occur if handling is mistaken leading to fatal or serious injuries.

 **CAUTION:** When a dangerous situation may occur if handling is mistaken leading to minor injuries or physical damage.

Note that some items described as "CAUTION" may lead to serious results depending on the situation. In any case, important information that must be observed is explained.

Limited warranty and disclaimer

1 Warranty period

Term of warranty for CKD products is one year from the date of delivery to the location designated by your company.

2 Scope of warranty

In the event of damages during the above term of warranty where it is deemed that CKD is responsible, CKD shall provide substitution of this product, free parts necessary for repair, or free repairs at our plant.

Note that the following faults are excluded from the warranty term:

(1) Product abuse/misuse contrary to conditions/environment recommended in its catalogs/specifications

(2) Failure caused by other than the delivered product

(3) Use other than original design purposes.

(4) Third-party repair/modification

(5) Failure caused by reason that is unforeseeable with technology put into practical use at the time of delivery

(6) Failure attributable to force majeure.

The warranty mentioned here covers the discrete delivered product. Only the scope of warranty shall not cover losses induced by the failure of the delivered product.

3 Compatibility confirmation

In no even shall CKD be liable for merchantability or fitness for a particular purpose, notwithstanding any disclosure to CKD of the use to which the product is to be put.



Safety precautions

Pneumatic components warning and cautions

Always read this section before starting use.

Refer to Pneumatic, vacuum and auxiliary components (No. CB-24SA) for general precautions of pneumatic components.

SPEED CONTROL VALVE WITH ADJUSTING DIAL

Design & Selection

CAUTION

- This valve can not be used as a stop valve that has no leakage.
Due to structure, a few leakage could occur.
- Care must be taken because the flow varies from the characteristics value on page 3 depending on the piping conditions before or after the product and temperature.
- Do not use this valve in circuits where ozone is generated intentionally.
Ozone resistance is sufficient for naturally generated ambient ozone. Packing deteriorates if ozone levels are high.
- This product is used with compressed air. Do not use with other fluids.
- Use within the product's specific specification range.
Consult with CKD when using the product outside specifications or for special applications.
 - Use with exceeding the specifications range may result in insufficient performance, and safety can not be secured.
 - Could not use in special applications and environment.
For example, use for special applications requiring safety including nuclear energy, railroad, aviation, ship, vehicle, medical equipment, equipment, or applications coming into contact with beverage or food, amusement equipment, emergency shutoff circuits, press machine, brake circuits, or for safeguard.
- Confirm that the product will withstand the working environment.
 - Use is not possible in environments in which functionality is impaired.
For example, special environments reaching high temperatures, having chemical atmospheres, or having chemicals, vibration, humidity, moisture, dripping, or gas are present. Environments where ozone is generated.
 - Do not use the product in the place that the product could directly contact with cutting fluids, coolant or spatter, etc.
- Understand compressed air features before designing a pneumatic circuit.
 - The same functions as mechanical, hydraulic, and electrical methods cannot be anticipated if instantaneous service interruption and holding are required during an emergency stop.
 - Pop-out, air discharge, or leakage due to air compression and expansion could occur.

- Install "pressure switch" and "shut-off valve" on compressed air inlet of equipment.
 - The shut-off valve exhausts compressed air in the pneumatic circuit, and prevents accidents caused by operation of the pneumatic devices by residual pressure. The pressure switch will disable operation unless set pressure is reached.

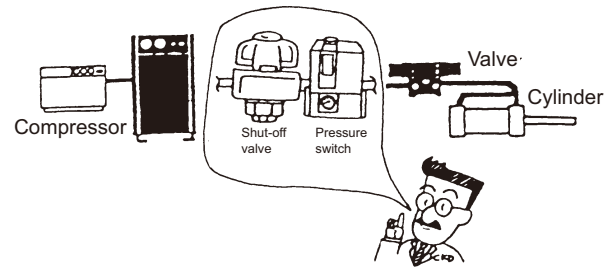

- Confirm that PTFE can be used.
The sealant contains PTFE (polytetrafluoroethylene resin) powder. Please ensure that this does not hinder use.
- Indicate the maintenance conditions in the device's instruction manual.
 - The product's function can drop markedly with working status, working environment, and maintenance, and can prevent safety from being attained.
The product should be able to deliver sufficient functionality provided that maintenance is carried out properly.
- Service life could be shortened due to splashed lubricant and rubber part deterioration when using ultra dry air.
- Do not continuously press or apply loads to one-touch coupling push rings.
 - It may no longer be possible to grip the tube.
 - Ensure that the push ring is not pressed continuously during transport with the product fitted to equipment.

Installation & Adjustment

CAUTION

- The needle lock is released when the knob is pulled, and is locked when pressed.
- The knob opens when turned to the right and closes when turned to the left.

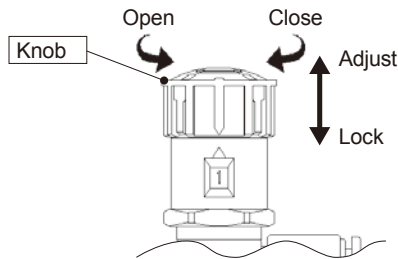

- If opening by rotating the knob to the left, the dial will indicate a right rotation for the standard type, and a left rotation for the compact type.
- After adjusting speed, press the knob and confirm that the needle is locked.
- The needle control range is 1 to 7 or 1 to 10 rotations, and the needle should be operated with torque of 0.05 N·m or less.
If the knob is forcibly rotated with greater torque than this, flow characteristics may become warped, or a fault may occur.
- Even when the needle is fully closed, the dial indication is not 0.
The flow rate in the dial indication is calibrated when the needle is not fully closed. Note that 0 is not necessarily indicated when the needle is fully closed. If "0" is exceeded, the dial will indicate a "-" value.
- Adjust speed by opening when the needle is nearly closed.
If the needle is open, the actuator could pop out suddenly and cause a hazard.
- Check flow direction with JIS symbol.
If installed in reverse, speed adjustment will not be applied and the actuator could pop out, creating a hazard.
- Final speed must be adjusted as necessary.
Speed differs greatly depending on product differences, working conditions, actuator differences, and temperature, so confirm the final speed as necessary.
- Install an air filter in front of the circuit.
The flow varies depending on clogging or foreign matters adhered in the orifice.
- When connecting pipes, tighten screws with the specified torque (see Table 1-(1)). Furthermore, if tightening further by positioning the rotation count indication window, tighten with the torque indicated in Table 1-(2) or less.
Failure to observe this could result in a fault, and therefore the knob should not be gripped when connecting pipes. It is not possible to position connection port diameter M5 by further tightening, and so caution is advised.

Table 1 Pipe screw tightening torque

Screw size	(1) When connecting pipes (N·m)	(2) When further tightening (N·m)
M5	1.0 to 1.5	-
R1/8	3 to 5	9 or less
R1/4	6 to 8	14 or less
R3/8	13 to 15	24 or less
R1/2	16 to 18	30 or less

- Securely insert the tube until it contacts the joint's tube end, and check that it does not come off the joint.
- Do not take the product out of the packing bag until just before piping.
 - Foreign matter could enter the pneumatic component from the piping port and result in faults or faulty operation.
- When connecting pipes, wrap sealing tape in the opposite direction from threads starting 2 mm inside from the end of piping threads.
 - If sealing tape protrudes from pipe threads, it could be cut when screwed in. This could cause the tape to enter the pneumatic components and lead to faults.

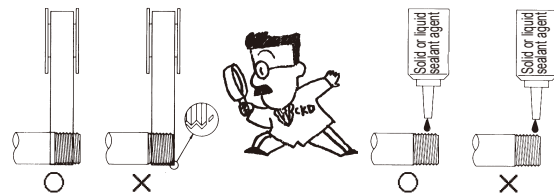

- Warnings and cautions of joint/tube
 - Refer to Pneumatic, vacuum and auxiliary components (No. CB-24SA) for warnings and cautions of joint/tube.
- Always flush just before connecting to pneumatic components.
 - Foreign matter that enters during piping must not enter pneumatic components.
- Apply a leakage detection agent on pipe connections with a brush, and check for air leaks.
 - Tube may come off and fly out, causing an accident.
- Apply a leakage detection agent on pipe connections with a brush, and check for air leaks.
 - Apply a leakage detection agent on pipe connections with a brush, and check for air leaks.
- Connect piping so that connections are not dislocated by system movement, vibration, or tension.
 - Control of actuator speed will be disabled if piping on the exhaust side of the pneumatic circuit is disengaged.
 - When using the chuck holding mechanism, the chuck will be released creating a hazardous state.
- Ensure spaces around the pneumatic component for installation, removal, wiring, and piping work.
- Avoid use in applications involving continuous turning or swaying.
 - Otherwise the joint could be damaged.
- Do not apply lateral load to the main unit during or after installation.
- Avoid use in areas with high vibration or impact.

During Use & Maintenance

WARNING

- Stop air and confirm that there is no residual pressure before replacing the tube.

Related products

Needle valve with adjusting dial DVL series

- Linear flow characteristics
- Visible control of flow rates
- Use as a speed control valve
- Degrease type available
- Unrestricted installation

Catalog No. CC-860A



Linear slide cylinder LCR series

- Up to 10% lighter than previous model through adoption of aluminum tape
- Improved rigidity through adoption of highly rigid linear guide and slide table
- Improved design freedom with left/right symmetrical stopper, multi-face piping, and positioning hole, etc.

Catalog No. CB-029SA

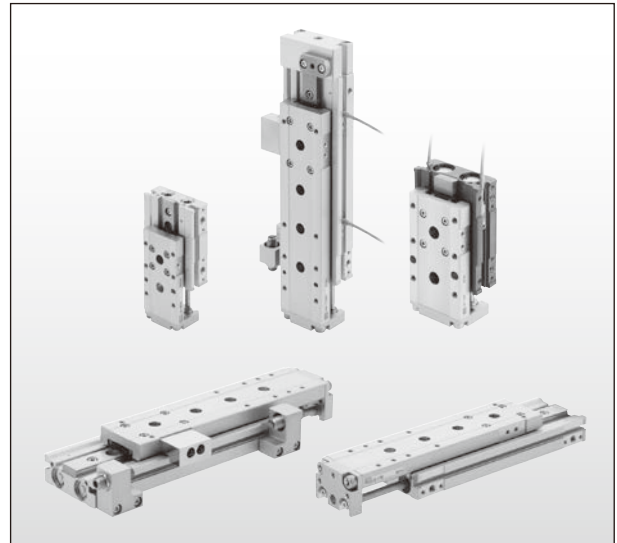

The goods and/or their replicas, or the technology and/or software found in this catalog are subject to complementary export regulations by Foreign Exchange and Foreign Trade Law of Japan. If the goods and/or their replicas, the technology and/or software found in this catalog are to be exported, law requires that the exporter makes sure that they will never be used for the development or manufacture of weapons for mass destruction.