



특징 (Character)

- 링크레버 구동방식의 각도개폐형 제품
Angular type by link lever driving unit
- 각형 BODY형태로 3방향 취부가능
Easy mounting to 3-direction (square type body)
- 개폐검출 센서 전기종 부착가능
Magnetic sensor is available for open-close sensing Kinetics



링크레버 방식 (Link lever type)

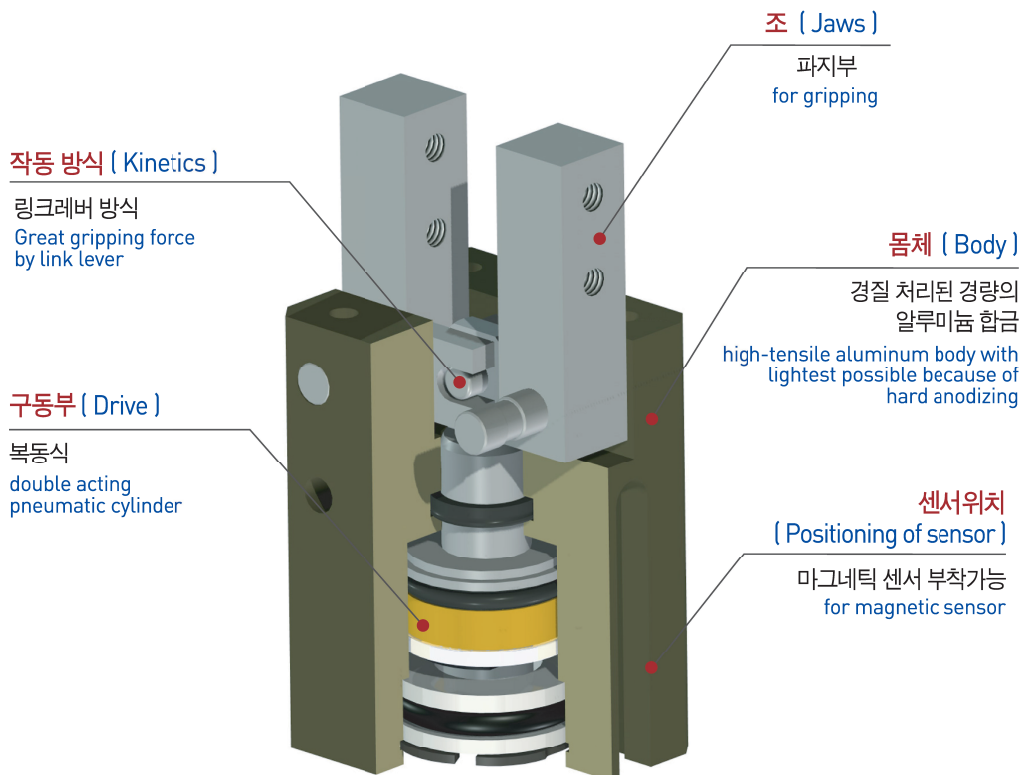

부품분해도 (Exploded view)

※ 본 분해도는 한 제품을 예시하였으므로 기종별로 차이가 있을 수 있습니다
 ※ This is exploded view illustrates a certain product only. The contents may vary by product models.

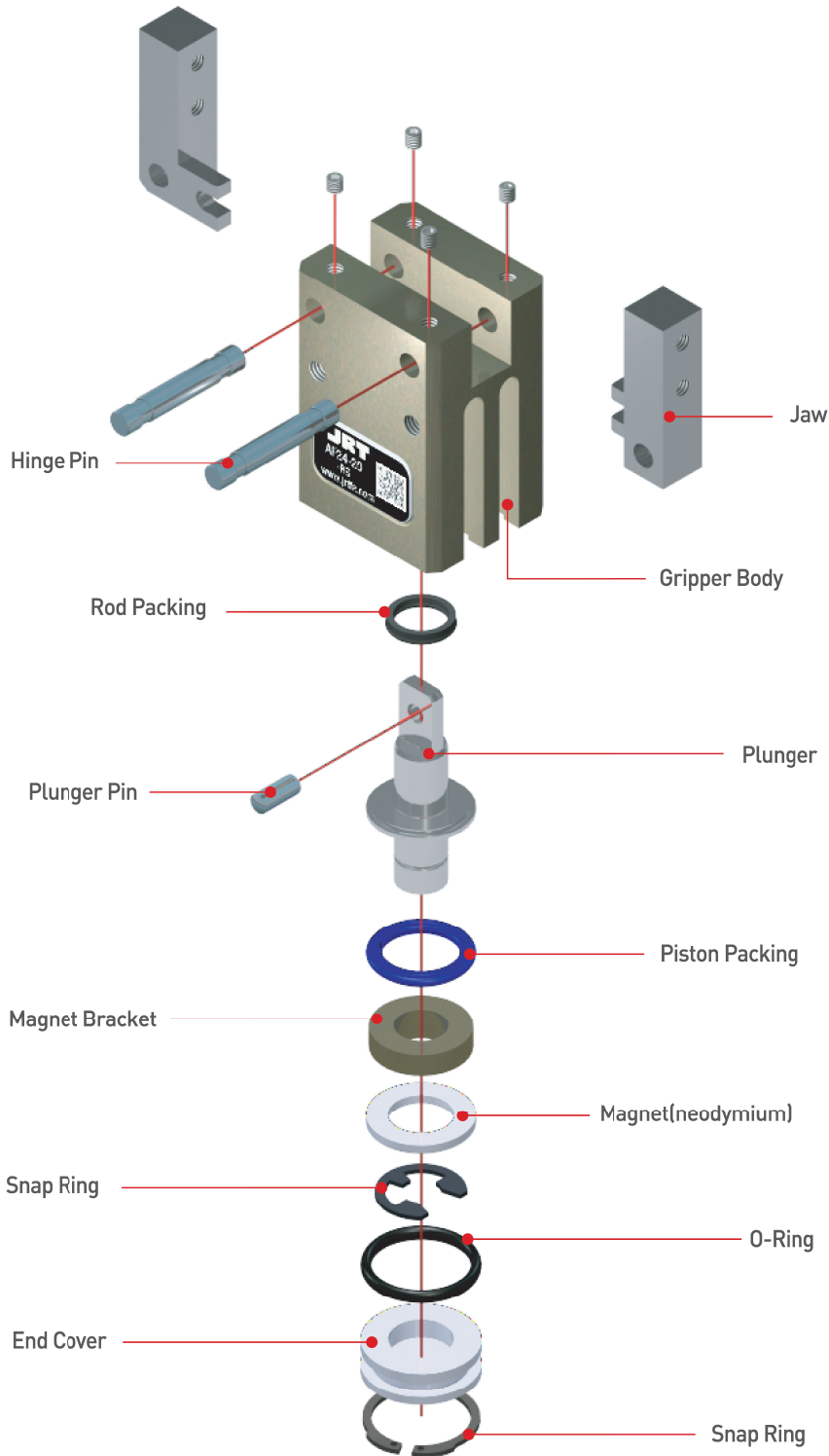

- AF101
- AF02
- AF04P
- AF105P
- AF10
- AF13
- AF14
- AF15
- AF316
- AF316L
- AF416
- AF17
- AF117
- AF24**
- AF26
- AF28D
- AF28DS
- AF30
- AF30L
- AF46
- AF56L
- RAF56N
- MF16
- JPGB
- JEGG
- JEGB
- JEGC
- JEGD
- JVGE

주문기호 (How to Order)

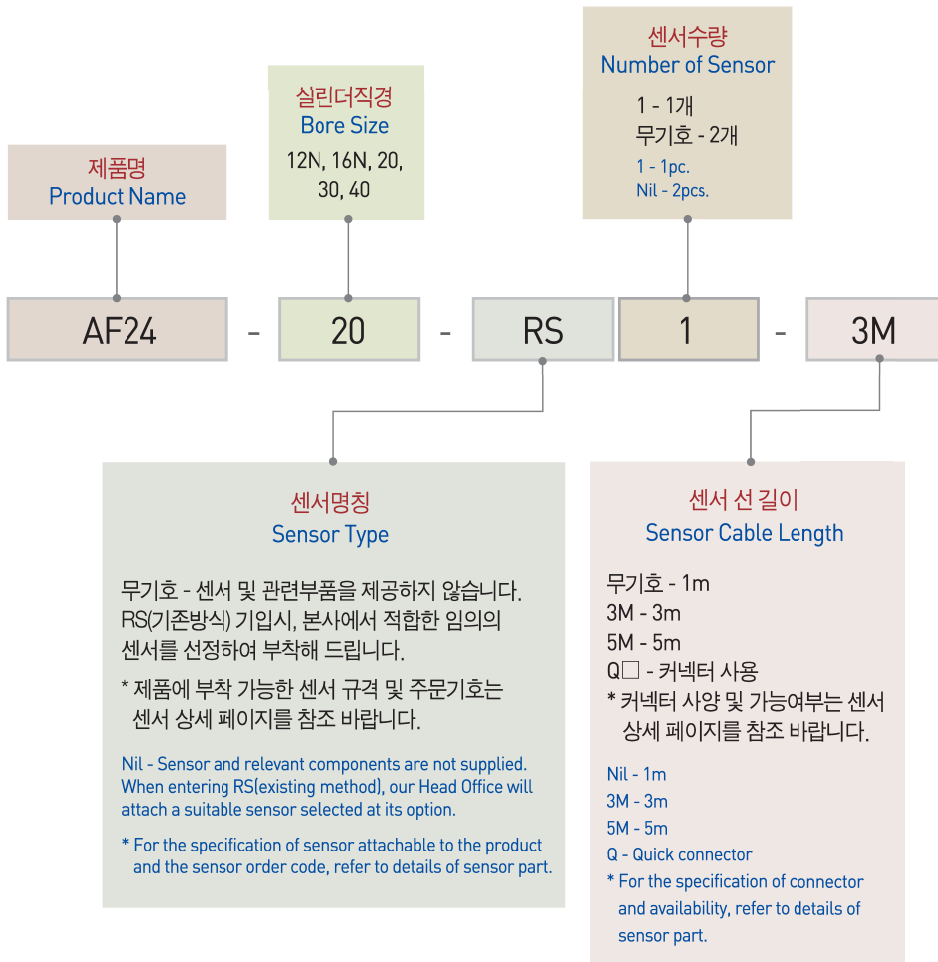

▣ 제품사양 (Specification)

P=공기압력(bar), L=작용점까지의 거리(mm)
 P = Air Pressure(bar), L = Gripping point distance(mm)

제품명칭 Products Name	AF24-12N	AF24-16N	AF24-20	AF24-30	AF24-40	단위 Unit
개폐범위 Stroke	-5 to 15	-5 to 15	-5 to 20	-5 to 20	-5 to 25	degree
제품중량 Weight	0.05	0.06	0.2	0.41	0.76	kg
최대치구길이 Max. length attach	45	60	70	85	120	mm
배관접속구 Fitting size	M5	M5	M5	PF(G) 1/8	PF(G) 1/8	
파지력 : 열림시 Gripping force : Open	9.81P/0.1L	19.62P/0.1L	36.3P/0.1L	110.85P/0.1L	234.46P/0.1L	N
파지력 : 닫힘시 Gripping force : Close	7.36P/0.1L	14.72P/0.1L	27.47P/0.1L	86.33P/0.1L	191.3P/0.1L	N
1사이클당 공기소모량 Air consumption per cycle	0.3	0.7	1.6	4.7	11.0	cm ³
닫힘시/열림시 시간 Closing / Opening time	0.01/0.01	0.01/0.01	0.01/0.01	0.01/0.01	0.01/0.01	sec
반복정밀도 Repeat accuracy	0.03	0.03	0.03	0.03	0.03	mm
연속사용회수 Continuation usage amount	60	60	60	45	40	cpm
사용압력 Operating pressure	3~7					bar
주위온도 Ambient temperature	-5 to 60					℃
윤활 Lubrication	불필요 Needless					

반복정밀도 : 연속 100회 작동후 측정치
 After 100 consecutive strokes to end positions

▣ NOTE

- AF101
- AF02
- AF04P
- AF105P
- AF10
- AF13
- AF14
- AF15
- AF316
- AF316L
- AF416
- AF17
- AF117
- AF24**
- AF26
- AF28D
- AF28DS
- AF30
- AF30L
- AF46
- AF56L
- RAF56N
- MF16
- JPGB
- JEGG
- JEGB
- JEGC
- JEGD
- JVGE

작용점에서의 파지력 (Gripping Force From a Point of Action)

범례 (Legend) : — 7[bar] — 5[bar] — 3[bar]

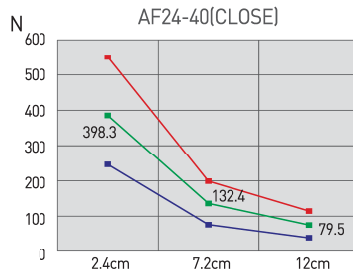
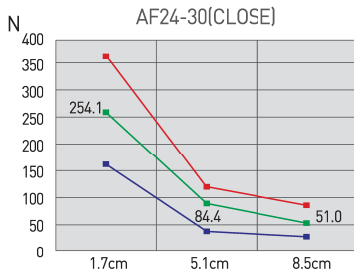
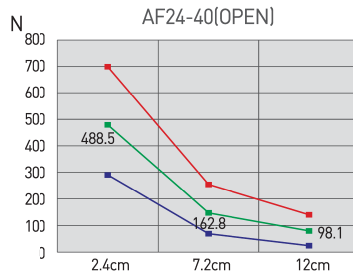
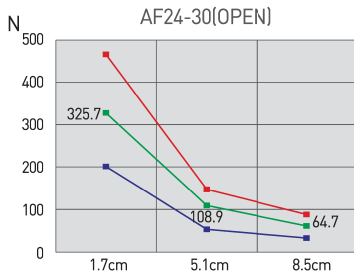
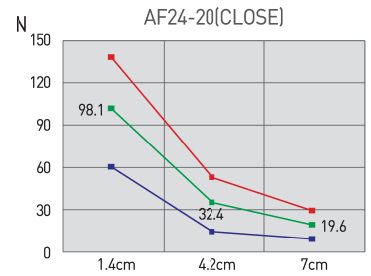
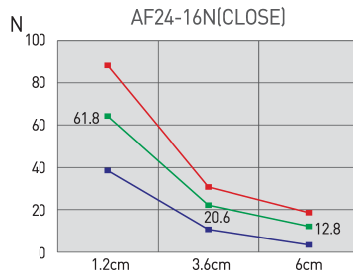
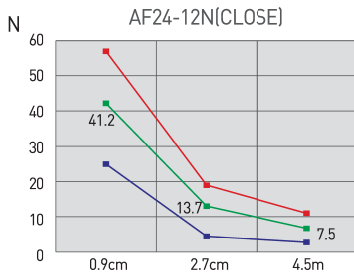
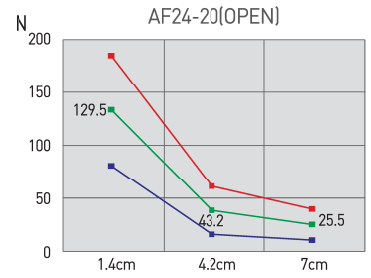
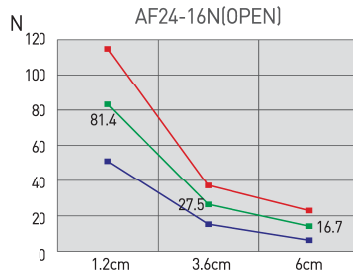
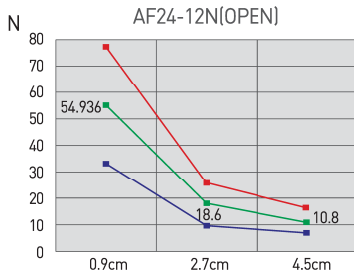

AF24-12N

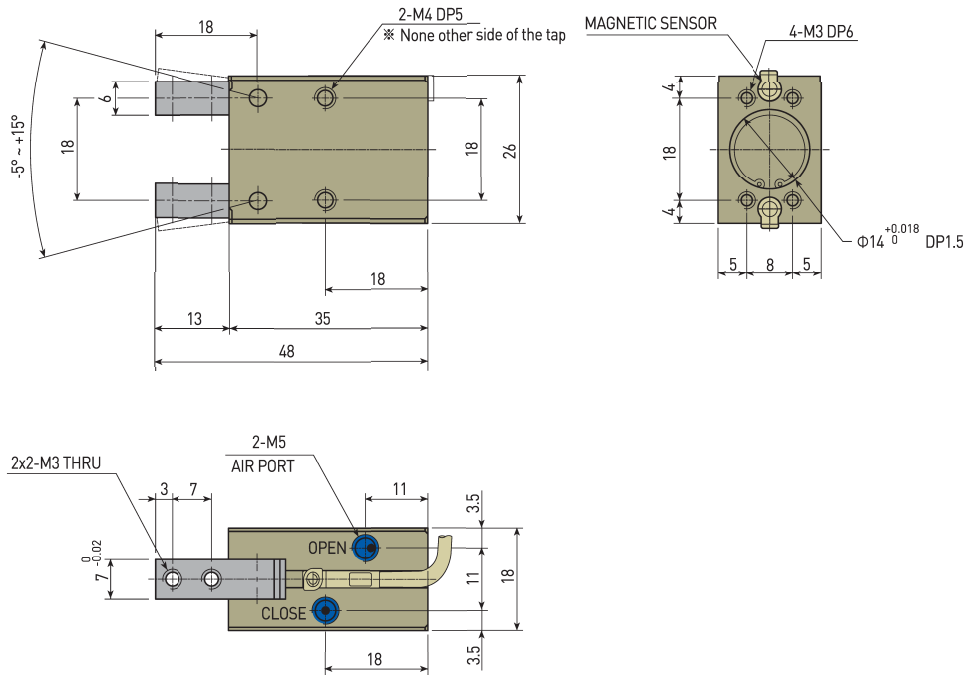

AF24-16N

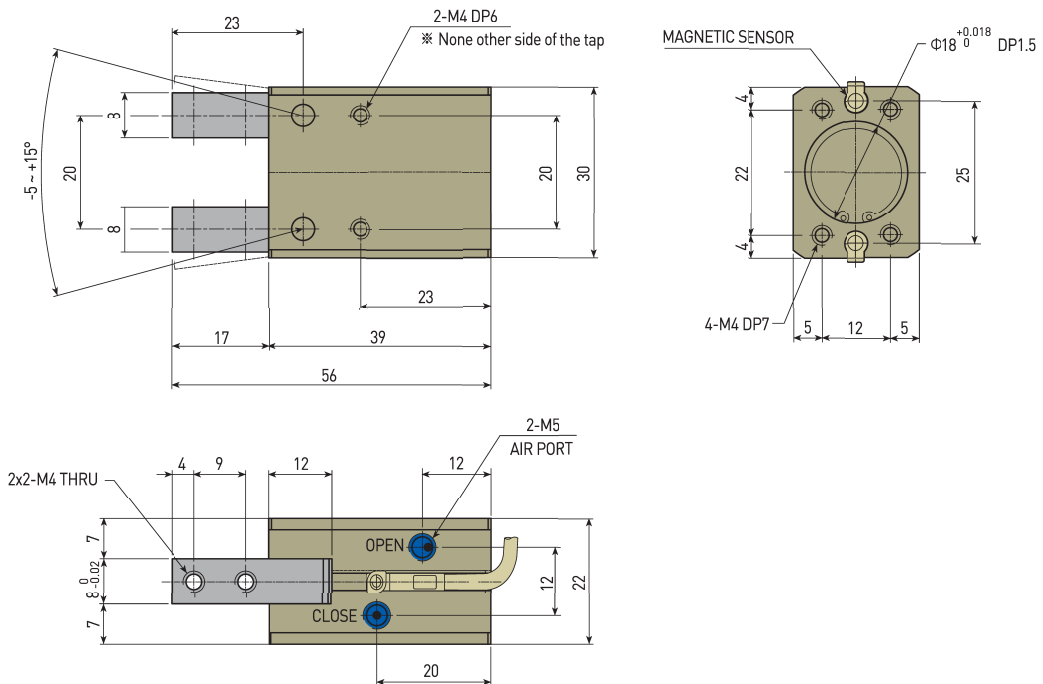

- AF101
- AF02
- AF04P
- AF105P
- AF10
- AF13
- AF14
- AF15
- AF316
- AF316L
- AF416
- AF17
- AF117
- AF24**
- AF26
- AF28D
- AF28DS
- AF30
- AF30L
- AF46
- AF56L
- RAF56N
- MF16
- JPGB
- JEGG
- JEGB
- JEGC
- JEGD
- JVGE

AF24-20

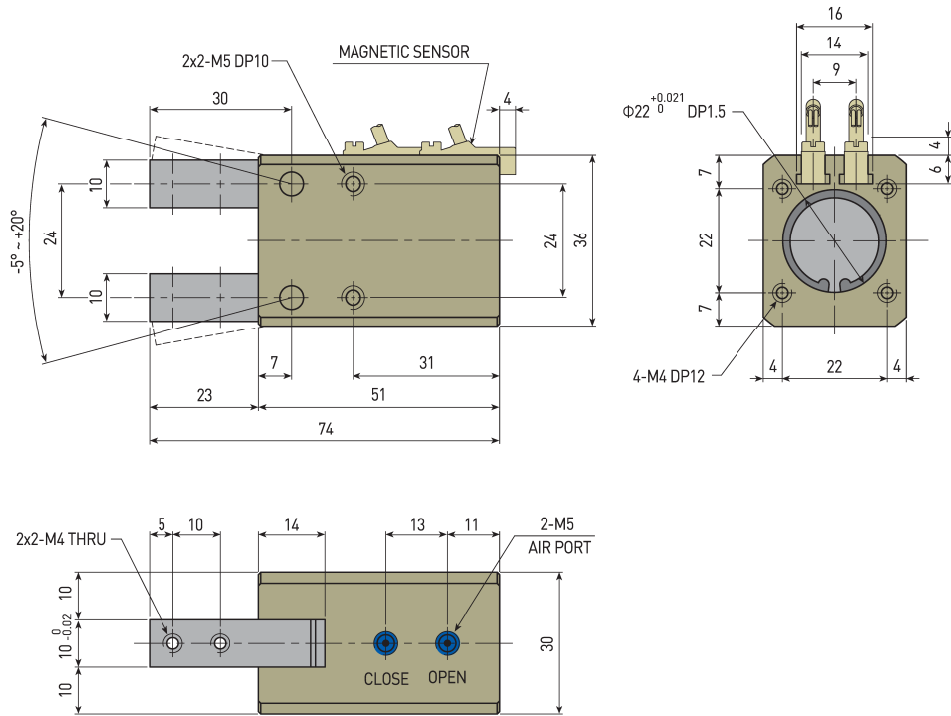

AF24-30

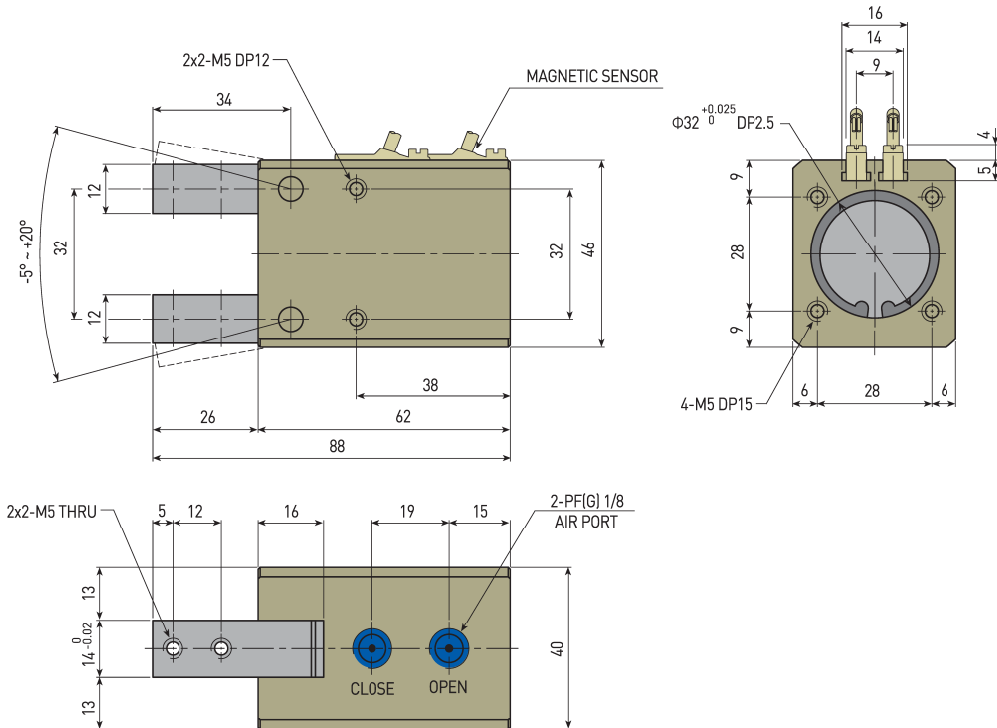

AF24-40

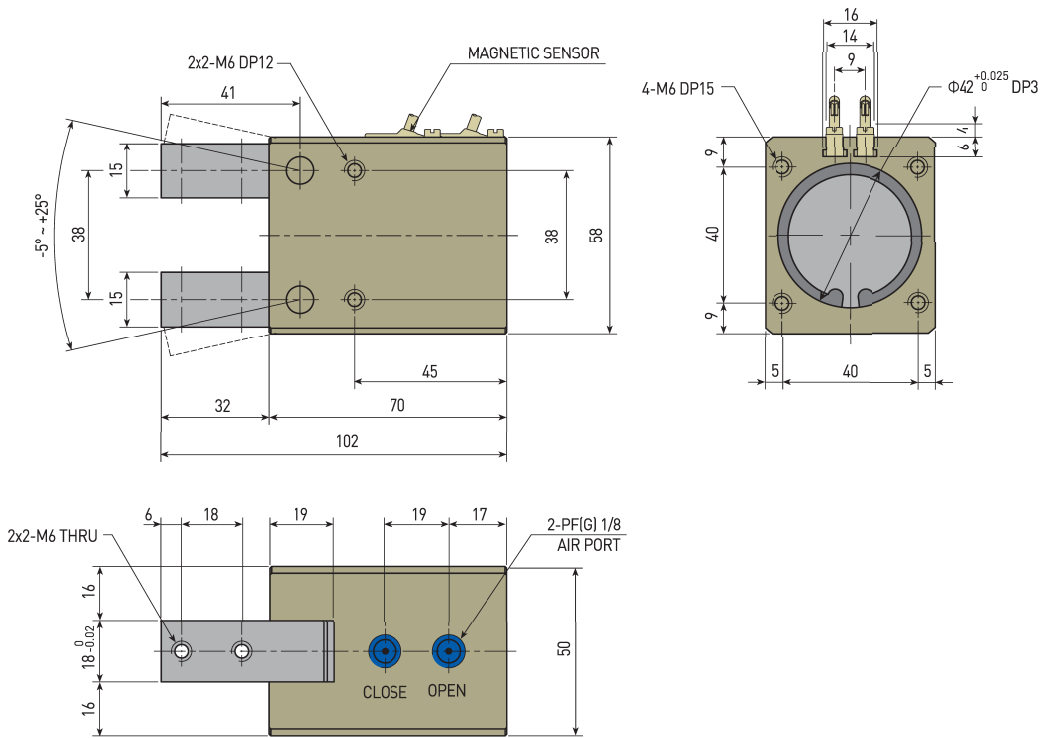

- AF101
- AF02
- AF04P
- AF105P
- AF10
- AF13
- AF14
- AF15
- AF316
- AF316L
- AF416
- AF17
- AF117
- AF24**
- AF26
- AF28D
- AF28DS
- AF30
- AF30L
- AF46
- AF56L
- RAF56N
- MF16
- JPGB
- JEGG
- JEGB
- JEGC
- JEGD
- JVGE